



HYDRACART INSTRUCTIONS

REIMANN & GEORGER CORPORATION
CONSTRUCTION PRODUCTS
P/N 6122071

BUFFALO, NY 14225
02/27/08

1 SAFETY

1.1 INTRODUCTION

Your Reimann & Georger Corporation HydraCart has been engineered to provide sawing performance, long term economics and safety advantages that no other type can match. However, even a well-designed and well-built cart can malfunction or become hazardous in the hands of an inexperienced and/or untrained user. Therefore, read this manual and related equipment manuals thoroughly before operating your saw to provide maximum safety for all operating personnel, and to get the maximum benefit from your equipment.

1.2 SAFETY DEFINITIONS

A safety message alerts you to potential hazards that could injure you or others or cause property damage. The safety messages or signal words for product safety signs are **DANGER**, **WARNING**, and **CAUTION**. Each safety message is preceded by a safety alert symbol and is defined as follows:

DANGER: Indicates an imminently hazardous situation which, if not avoided, **will** cause death or serious injury. This safety message is limited to the most extreme situations.

WARNING: Indicates a potentially hazardous situation which, if not avoided, **could** result in death or serious injury.

CAUTION: Indicates a potentially hazardous situation which, if not avoided, **may** result in minor or moderate injury. It may also be used to alert against unsafe practices that may result in property-damage-only accidents.

1.3 POWER SOURCE, HYDRACART AND SAW SAFETY LABELS

These labels warn you of potential hazards that could cause injury. Read them carefully. If a label comes off or becomes illegible, contact Reimann & Georger Corporation for a free replacement.

1.4 HYDRACART AND SAW SAFETY RULES

1. Only trained personnel shall operate the HydraCart or perform repairs. A trained person is one who has read and thoroughly understands this instruction manual and related equipment manuals and, through training and experience, has shown knowledge regarding the safe operational procedures.
2. Sawing area must be kept clear of unauthorized personnel at all times. Place barricades or secure the area with signs and a roped boundary to prevent personnel injury.
3. Never use the saw in an explosive atmosphere and/or near combustible material that could be ignited by a spark.
4. Do not use a saw that shows any signs of damage. Do not use the saw if the blade does not stop rotating when the power-activating trigger lever is released.
5. The guard provides protection against contact with moving parts, ejected debris, and during wet cutting operations, thrown water and concrete slurry. Adjust the blade guard for the cut being made. Never run the saw without the blade guard in place.
6. Never allow anyone to stand in front of, or in line with, the blade forward of the guard.
7. Always use blades that meet applicable safety code specifications. Read and comply with blade manufacturer's instructions and safety precautions provided with the blade. Destroy any blade with cracks, chips, gouges, or loose or missing tips.

8. **Always** use safety footwear, safety goggles or face shields, and hearing and head protection devices. Safety shoes **MUST** provide good footing to prevent slipping or falling down. Gloves protect the hands from chips and should be worn. During dry cutting operations, provide also adequate ventilation or approved NIOSH or MSHA respirators in closed areas to avoid breathing dust. During wet cutting operations, use also a snug fitting wet suit.
9. Do not use the saw or cart when you are tired or fatigued.
10. Never operate the saw or cart under the influence of drugs, alcohol, or medication.
11. Always carry the saw in its de-energized state.
12. Keep the saw handles and cart handles dry, clean, and free of oil or fuel.
13. The cart and saw are not insulated. Do not start cutting without first de-energizing electrical wiring near the cutting site or imbedded in any concrete.
14. Prior to cutting, plan your cuts to prevent pinching of the blade or personnel injury from falling material.
15. Always hold the saw with both hands during operation. Use a firm grip on the handles.
16. Do not exceed maximum operating speed of blade.
17. Do NOT attempt to adjust the saw or cart during operation.
18. Keep clothing and all parts of the body away from moving parts of this saw when connected to a power source or being used.
19. Any slurry formed during wet cutting operations is very slick. Remove while still wet to prevent yourself or others from slipping while cutting. Slurry that has been allowed to dry is very difficult to remove.
20. Always shut off the hydraulic power and cooling water sources before disconnecting the hoses or servicing the saw. Never remove fittings or components when hydraulic fluid is hot.
21. Always shut off the hydraulic and cooling water sources when not using the equipment.
22. Ensure saw mountings screws are tight before operation.
23. Ensure depth control handle is locked in position while cutting.

2 SPECIFICATIONS

2.1 INTRODUCTION

Your Reimann & Georger HydraCart is a rugged versatile saw cart that will accept the Reimann & Georger Corporation model S14, S16, S20, S24 saw. The HydraCart is equipped with an adjustable blade depth control handle, depth lock, removable handles and a ballast box.

The following features are provided:

- Guide arm
- Depth of cut scale
- Lock handle

2.2 TECHNICAL DATA

The following specifications apply to the HydraCart.

	ENGLISH	METRIC
Cart Physicals		
Weight	211 lbs.	(96 kg.)
Length	79 5/8 in.	(2022.5mm)
Width	22 3/4 in.	(577.85 mm)
Height	37 1/4 in.	(946.15 mm)

3 SET UP

3.1 MOUNTING HYDRACART HANDLE

The handle for the cart is shipped in a folded position to reduce the shipping size.

1. Remove handle mounting bolts and reposition handle as shown.
2. Replace mounting bolts and tighten.

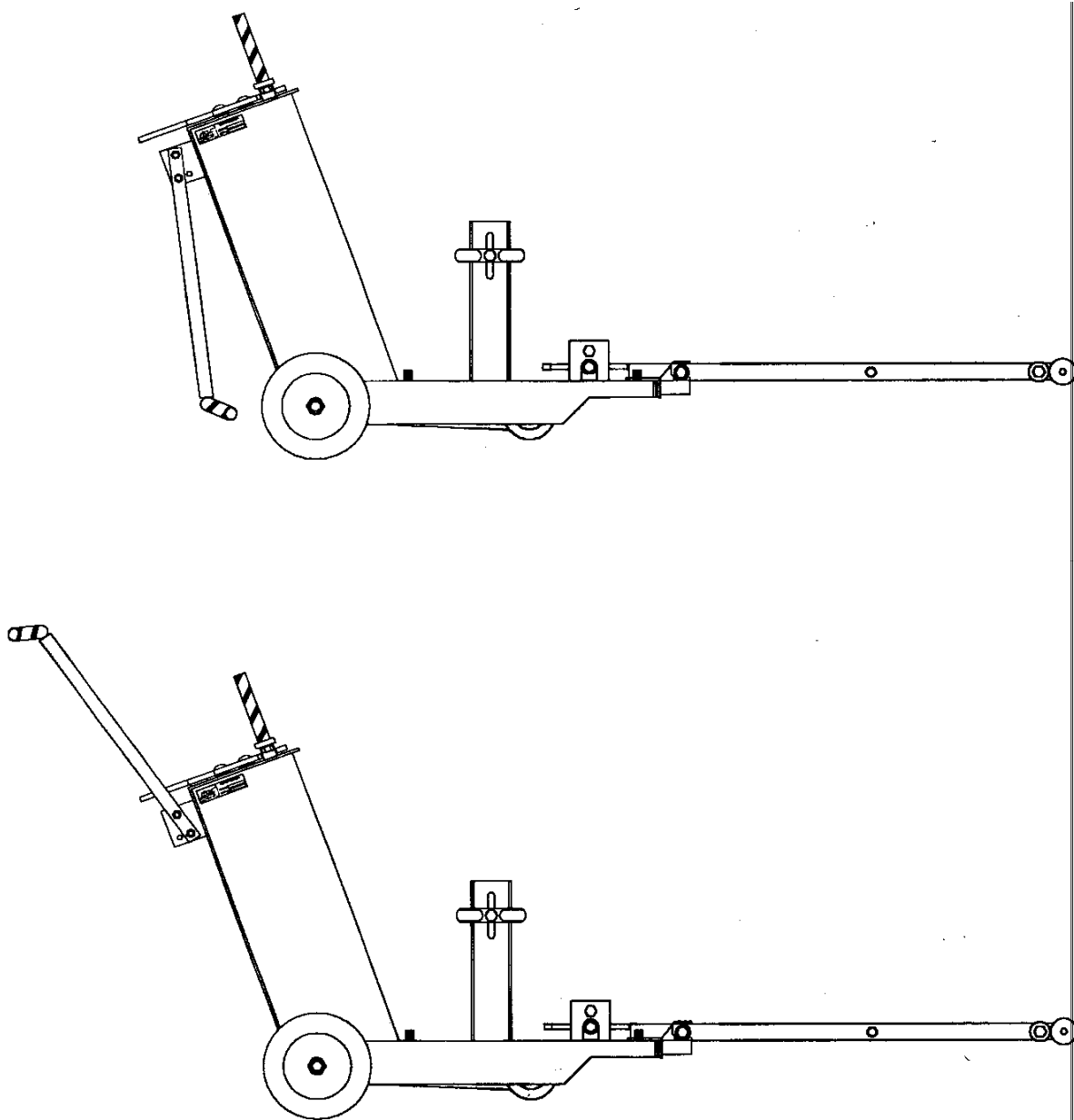

3.2 MOUNTING SAW TO CART

The saw mounts to the HydraCart by means of two mounting tabs on the saw. One tab is located between frame adjacent to hydraulic motor. The second is positioned adjacent to saw valve.

1. Loosen nut A to allow movement of the stud in the vertical direction (see figure 1).
2. Loosen forward and rear lock mounts.
3. Position front saw mounting tab onto forward cart mount.

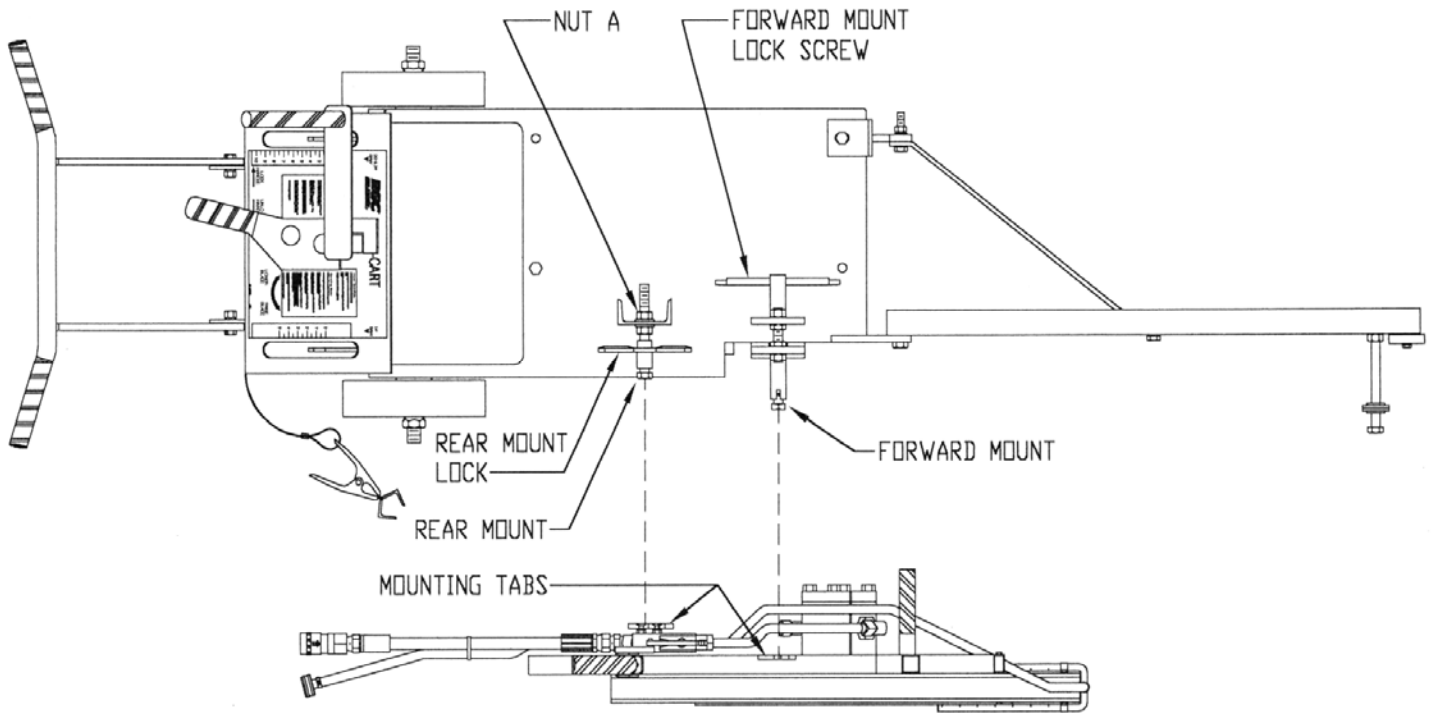

Figure 1

4. Rotate saw to engage mount adjacent to valve into rear cart mount. The rear cart mount moves vertically for alignment.
5. Snug mounts but do not tighten.
6. Disengage depth lock and rotate handle clockwise to raise saw for sufficient room to mount blade.
7. Mount saw blade (refer to saw manual for blade installation instruction).

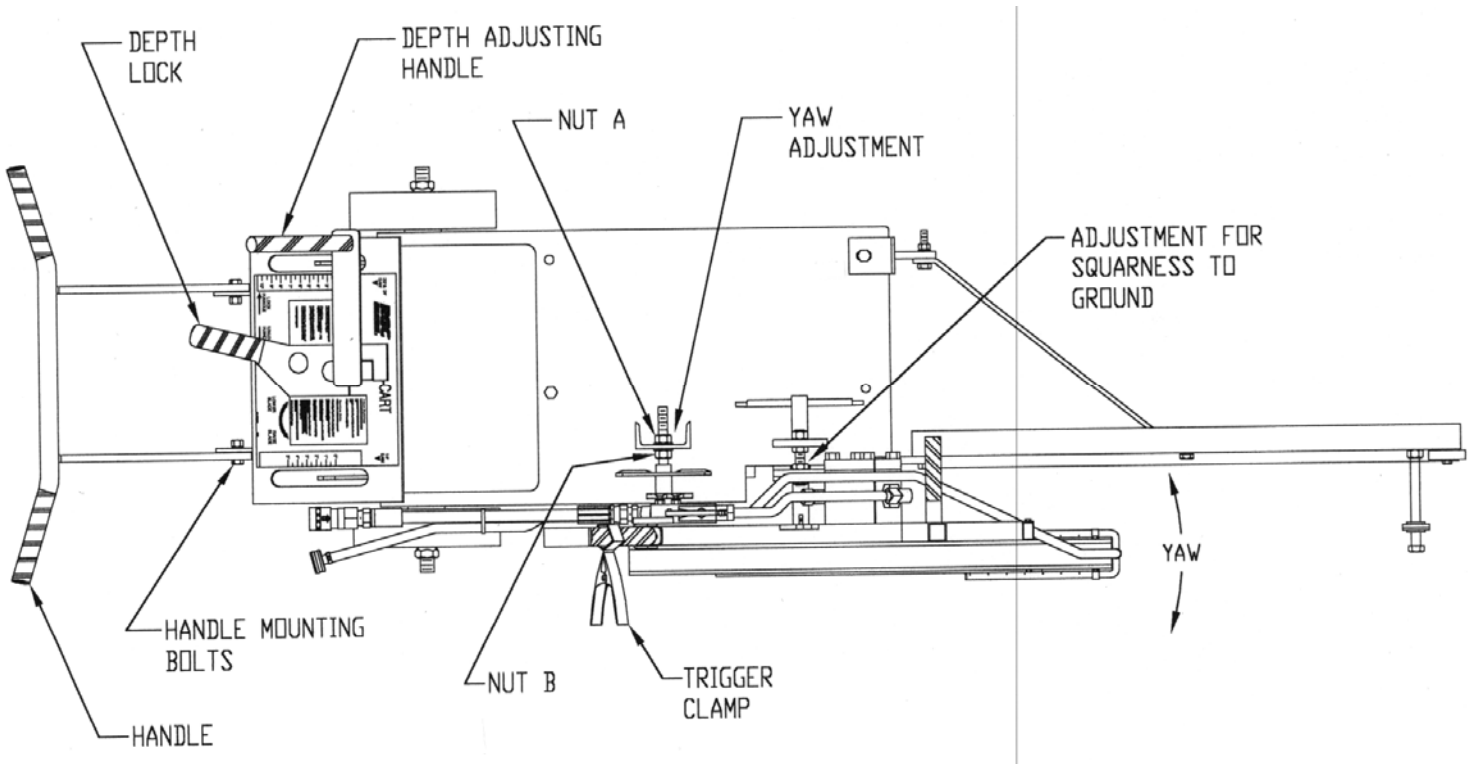

Figure 2

8. Adjust forward mount to ensure blade is square to ground. Loosen inner nut and tighten or loosen outer nut to adjust square to ground. Tighten after adjustment (see fig. 2).
9. Adjust yaw at rear mount to align blade with wheels. Loosen nut A and tighten or loosen nut B for alignment. Tighten nut A after adjustment.
10. Tighten forward and rear mount lock.

3.3 BALLAST BOX

The Ballast box can be filled with stone or gravel to add additional weight to the cart. Additional weight is required when making a cut greater than 3" deep.

4 OPERATION

Follow all the safety procedures in Chapter 1 of this manual and in the manual supplied with your saw and hydraulic power unit. **Failure to do this can cause equipment damage and/or personal injury.** Make sure you are wearing all your safety equipment including approved NIOSH or MSHA respirators during dry cutting or a wet suit during wet cutting.

4.1 STARTING THE SYSTEM

1. This cart is not insulated. Do not start cutting without first checking for live electrical wiring near the cutting site, or imbedded in the cutting medium. If power lines are unavoidable, consult power company before starting operation.
2. The following precautions must be observed when lifting the saw:
 - a. Be sure of your footing.
 - b. Keep hands off trigger to avoid accidental operation.
3. Insure the power supply is turned off. Adjust the blade guard to provide the best operator protection from the angle of the cut to be made.



WARNING:

THE GUARD PROVIDES PROTECTION AGAINST CONTACT WITH MOVING PARTS, EJECTED DEBRIS, AND DURING WET CUTTING OPERATIONS, THROWN WATER AND CONCRETE SLURRY. NEVER RUN THE SAW WITHOUT THE BLADE GUARD IN PLACE.

4. Always check the hydraulic flow and pressure rating of the hydraulic power unit before using to prevent equipment damage. Do not exceed the maximum hydraulic flow rate and pressure of 8 gpm (30 lpm) and 2500 psi (172 bar). Overspeeding the blade can cause equipment damage and possible personal injury.
5. Before starting your power supply, read and fully understand the operating manual provided.
6. Use caution when handling fuel for a gasoline engine driven hydraulic power source. Move the hydraulic power source at least 10 feet from the fueling point before starting the engine. Make sure the gas caps on the hydraulic power source and fuel can are properly tightened.

4.2 CUTTING PROCEDURE

1. Chalk a line where the cut is desired.
2. Position blade 1" over line of desired cut and push cart to ensure blade alignment with cut.
3. Position cart again to beginning point of cut. Start hydraulic power source.
4. Turn water supply on to saw if required.
5. Disengage the trigger lockout. Then depress (squeeze) the trigger to start the saw. Never exceed either the blade maximum operating speed or the blade manufacturer's rated speed.
6. Position trigger clamp on cart to secure trigger in the on position.
7. Disengage depth lock and rotate depth adjusting handle until blade contacts concrete. Zero pointer on appropriate scale for model of saw being used.

8. Rotate the depth adjusting handle to the depth desired. Feeding the rotating blade into the work surface using a steady, constant pressure.
9. Push cart forward keeping blade in line with chalk mark. If blade slows or climbs decrease feed rate of cut. Step cutting may be required with 20" or 24" blades.



WARNING:

ALWAYS START AND FINISH A SAW CUT WITH THE SAME WIDTH OF BLADE. IF BLADE TYPE OR WIDTH IS CHANGED, START A NEW SAW CUT. FAILURE TO DO THIS CAN CAUSE EQUIPMENT DAMAGE AND/OR PERSONAL INJURY.

4.3 SHUTDOWN AND STORAGE

1. Disengage depth lock and rotate depth adjusting handle until blade is clear of concrete surface.
2. To stop the saw, release the trigger clamp.
3. AFTER the blade has stopped rotating, stop the hydraulic power source following the procedure in the respective instruction manual.
4. Shut off water supply.



CAUTION:

ALWAYS SHUT OFF THE COOLING WATER WHEN THE TOOL IS NOT IN USE. LEAVING THE WATER RUNNING UNATTENDED CAN CAUSE EQUIPMENT OR PROPERTY DAMAGE.

5. Clean concrete slurry and debris off saw and cart. Once concrete slurry is dry, it is very hard to remove and may hamper the operation of moving parts.
6. Disconnect the hoses from the saw.



WARNING:

NEVER DISCONNECT ANY HYDRAULICALLY OPERATED PART OF THE SAW OR REMOVE HYDRAULIC COMPONENTS, LINES, OR FITTINGS WHILE THE POWER SOURCE IS RUNNING OR WHENEVER THE HYDRAULIC FLUID IS HOT.

LIQUID UNDER HIGH PRESSURE CAN PIERCE THE SKIN, CAUSING SERIOUS INJURY OR DEATH. HOT LIQUID CAN CAUSE SERIOUS PERSONAL BURNS. IF AN INJURY OCCURS, GET IMMEDIATE MEDICAL ATTENTION.

7. Secure the saw and hydraulic power source to prevent unauthorized use.
8. Store the saw in a clean, dry area away from exposure to high heat and humidity, water, other liquids, or freezing temperatures. Avoid temperatures low enough to cause condensation on the blade when moving it from storage to a higher temperature. Always handle and store blades carefully.

5 PARTS LIST

The following parts list applies to the HydraCart only. The parts list for the hydraulic power source is in the separate manual supplied for this item. Each item number on the following parts list can be matched with the item number shown on the assembly drawing.

Item Number	Part Number	Quantity	Description
1	6400654	1	Grip
2	5806296	1	HHCS 1/2 x 6
3	2004835	1	HYDRACART CRANK GRIP TUBE
4	2000506	1	HYDRACART CRANK
5	5806416	5	WASHER FLAT USS 3/4"
6			
7	5806368	6	NUT HEX TOPLOCK 3/8-16
8	5806406	5	WASHER FLAT SAE 3/8"
9	2004837	1	HYDRACART DEPTH INDICATOR ASSY
10	5806370	3	NUT HEX TOPLOCK 1/2-13
11			
12	5800130	2	SPRING
13	2000503	1	HYDRACART DEPTH ROD
14	5806251	1	HHCS 3/8-16 X 2
15	5806248	1	HHCS 3/8-16 X 1-1/4
16	5806410	9	WASHER FLAT USS 1/2"
17	5800136	1	SPRING COMP
18			
19	2004834	2	HYDRACART CRANK BEARING NUT
20	5104576	1	BEARING
21	2000505	1	HYDRACART LOCK HANDLE
22	2000502	1	HYDRACART UNDERCARRIAGE
23	2000501	1	HYDRACART MAIN FRAME
24	2004828	1	TRIGGER CLAMP
25	2004816	1	WIRE ROPE ASSY
26			
27	5804834	1	HHCS 1/2-13 X 5 FULLY THREADED
28	2004830	1	HYDRACART SCREW LOCK HANDLE
29	5806379	5	NUT HEX 1/2-13
30	2004832	1	HYDRACART FWD LOCK HANDLE BOLT-S14, S20, S24 SAW
31	5806387	2	NUT HEX JAM 1/2-13
32	2000479	1	HYDRACART GUIDE ARM FULL ASSY
33	2004838	1	HYDRACART PLUMB CUT ADJU. STUD
34	2004831	1	HYDRACART LOCK ARM ASSY
35	5806372	4	NUT HEX TOPLOCK 3/4-10 GR5
36	7648310	2	HYDRACART FRONT WHEEL 4"
37	7648311	2	HYDRACART REAR WHEEL 8"
38	2000507	1	HYDRACART REAR AXLE
39	6204062	1	DECAL "HYDRACART"
40	6400143	3	GRIP
41	2000504	1	HYDRACART HANDLE BAR
42	5806247	4	HHCS 3/8-16 X 1
43	2000478	1	HYDRACART BALLAST BOX
44	200---	1	HYDRACART FWD LOCK HANDLE BOLT-S16

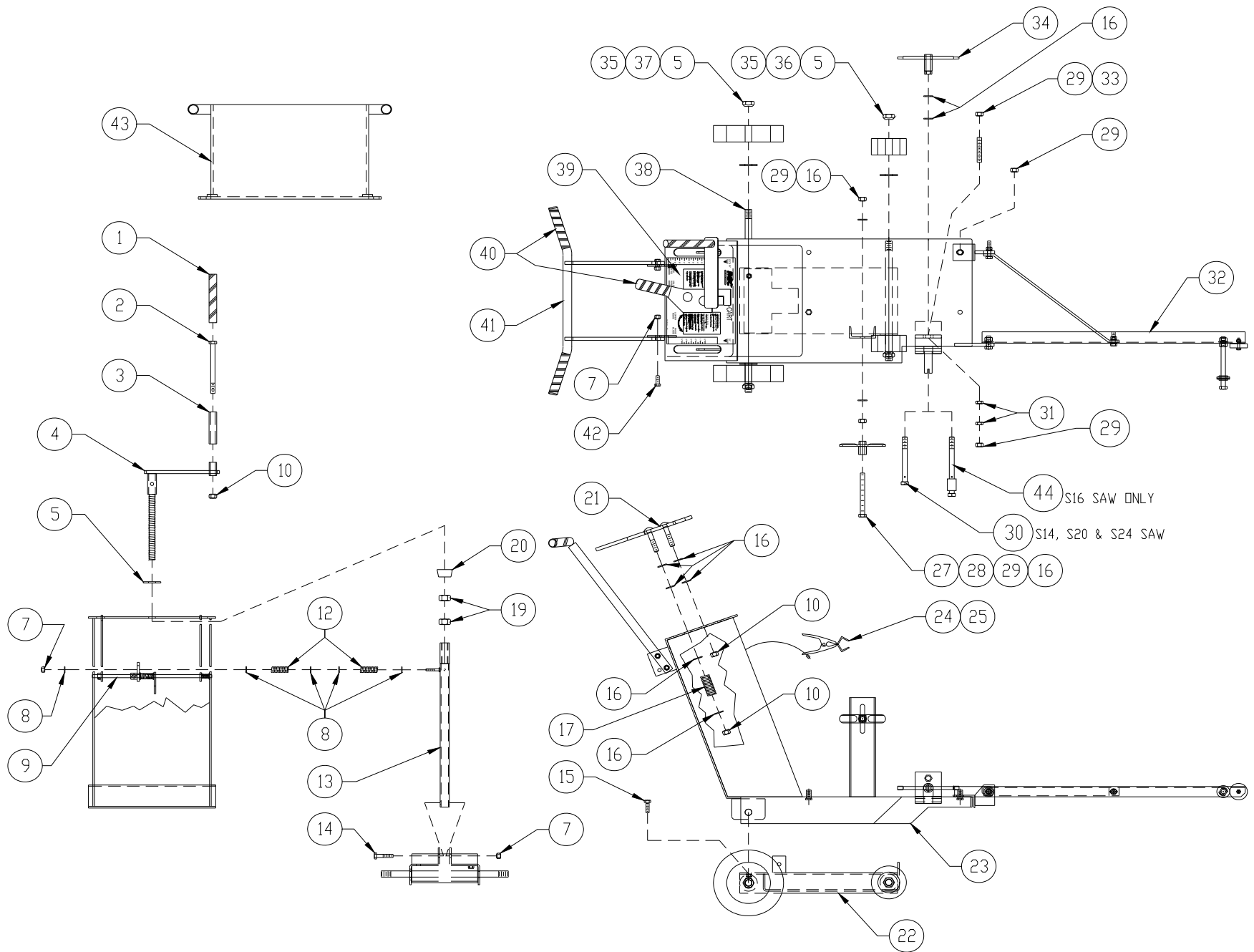

HydraCart Assembly

LIMITED PRODUCT WARRANTY

**Reimann & Georger Corporation
Hoisting and Construction Products**

A. LIMITED WARRANTY

Reimann & Georger Corporation (the "Manufacturer") warrants to the original purchaser (the "Buyer") that all Reimann & Georger Hoisting and Construction products shall be free of defects in material and workmanship for a period of one (1) year from date of original purchase.

B. MANUFACTURER'S OBLIGATIONS

The Manufacturer's sole obligation under this Limited Warranty is the repair or, at the Manufacturer's discretion, the replacement of parts found to be defective. Parts and equipment must have authorization from the Manufacturer prior to return to the Manufacturer or repair by an authorized service person. Costs of transportation and other expenses connected with replacing or repairing parts are not covered under this Limited Warranty.

C. PARTS MANUFACTURED BY OTHERS

This Limited Warranty does not cover any parts manufactured by others. Such parts are subject to the warranty, if any, of their respective manufacturers, and are to be repaired only by a respective authorized service person for such parts. The Manufacturer shall have no obligation to undertake repairs of parts manufactured by others.

D. NO SPECIAL, INCIDENTAL, OR CONSEQUENTIAL DAMAGES

IN NO EVENT SHALL THE MANUFACTURER BE LIABLE TO THE BUYER OR ANY OTHER PERSON FOR ANY INDIRECT, SPECIAL, INCIDENTAL OR CONSEQUENTIAL LOSSES OR DAMAGES CONNECTED WITH THE USE OF THE PRODUCT UNDER THIS LIMITED WARRANTY. SUCH DAMAGES FOR WHICH THE MANUFACTURER SHALL NOT BE RESPONSIBLE INCLUDE, BUT ARE NOT LIMITED TO, LOST TIME AND CONVENIENCE, LOSS OF USE OF THE PRODUCT, THE COST OF A PRODUCT RENTAL, COSTS OF GASOLINE, TELEPHONE, TRAVEL, OR LODGING, THE LOSS OF PERSONAL OR COMMERCIAL PROPERTY, AND THE LOSS OF REVENUE.

E. NO LIABILITY IN EXCESS OF PURCHASE PRICE

IN NO EVENT SHALL THE MANUFACTURER'S OBLIGATIONS UNDER THIS LIMITED WARRANTY EXCEED THE PURCHASE PRICE OF THE PRODUCT.

F. NO EXTENSION OF STATUTE OF LIMITATIONS

ANY REPAIRS PERFORMED UNDER THIS WARRANTY SHALL NOT IN ANY WAY EXTEND THE STATUTES OF LIMITATIONS FOR CLAIMS UNDER THIS LIMITED WARRANTY.

G. WAIVER OF OTHER WARRANTIES

THE EXPRESS WARRANTIES SET FORTH IN THIS LIMITED WARRANTY ARE IN LIEU OF AND EXCLUDE ANY AND ALL OTHER WARRANTIES, EXPRESS OR IMPLIED, INCLUDING, BUT NOT LIMITED TO, THE IMPLIED WARRANTIES OR MERCHANTABILITY AND FITNESS FOR A PARTICULAR PURPOSE.

H. PROCEDURE FOR WARRANTY PERFORMANCE

If the product fails to perform to the Manufacturer's specifications, the Buyer must provide the Manufacturer with the applicable model and serial numbers, the date of purchase, and the nature of the problem.

I. ADDITIONAL EXCLUSIONS FROM THIS LIMITED WARRANTY. THIS LIMITED WARRANTY DOES NOT COVER ANY OF THE FOLLOWING:

1. Equipment which has been abused, damaged, used beyond rated capacity, or repaired by persons other than authorized service personnel.
2. Damage caused by acts of God which include, but are not limited to, hailstorms, windstorms, tornadoes, sandstorms, lightning, floods, and earthquakes.
3. Damage under conditions caused by fire or accident, by abuse or by negligence of the user or any other person other than the Manufacturer, by improper installation, by misuse, by incorrect operation, by "normal wear and tear", by improper adjustment or alteration, by alterations not completed by authorized service personnel, or by failure of product parts from such alterations.
4. Costs of repairing damage caused by poor or improper maintenance, costs of normally scheduled maintenance, or the cost of replacing any parts unless done as the result of an authorized repair covered by the one (1) year Limited Warranty.
5. Costs of modifying the product in any way once delivered to the Buyer, even if such modifications were added as a production change on other products made after the Buyer's product was built.

J. NO AUTHORITY TO ALTER THIS LIMITED WARRANTY

No agent, representative, or distributor of the Manufacturer has any authority to alter the terms of this Limited Warranty in any way.