

**HV2310 PUMP INSTALLATION INSTRUCTIONS
 (10 GPM PUMP P/N 6901510)**

BEFORE INSTALLATION

1. Read these instructions thoroughly before starting work. If you don't understand a procedure, call Reimann & Georger Corporation or its distributors for assistance.
2. Figures 1 through 4 included in these instructions show the assembly of all the parts that comprise the pump installation to the engine block. Each item number on the following parts list can be matched with the item numbers shown on these figures. If any parts you have ordered are missing, call Reimann & Georger Corporation or your local distributor for assistance. Return any damaged parts to the place of purchase immediately. Do NOT substitute any components.

Item No.	Part Number	Quantity	Description
1	6700904	1	COUPLING 3/4" FOR 6901510 PUMP
2	6901510	1	PUMP 10 GPM
3	6700907	1	SPIDER
4	6700906	1	ENGINE COUPLER
5	5806406	2	3/8 SAE WASHER
6	5806407	2	3/8 LOCK WASHER
7	5806194	2	3/8-16 X 1-1/4 SOCKET HEAD SCREW
8	6901502	1	ACCESS COVER
9	5604541	1	FITTING—HIGH PRESSURE
10	5601390	1	FITTING—LOW PRESSURE

3. Review and follow all the safety rules given in Chapter 1 of the HydraPak manual before proceeding.



WARNING:

DO NOT ADJUST OR REMOVE HYDRAULIC COMPONENTS, LINES, OR FITTINGS WHILE THE HYDRAPAK IS RUNNING OR WHENEVER THE HYDRAULIC FLUID IS HOT. LIQUID UNDER HIGH PRESSURE CAN PIERCE THE SKIN, CAUSING DEATH OR SERIOUS INJURY. IN CASE OF INJURY, GET IMMEDIATE MEDICAL ATTENTION.

PREVENT ACCIDENTAL STARTUP BY DISCONNECTING THE NEGATIVE WIRE FROM THE BATTERY TERMINAL.

4. Never lift, suspend, or lower any pump unit by the hydraulic hoses.

REMOVING OLD PUMP

1. The work area must be dry and clean and be free of water, chemical contaminants, construction debris, and excessive dust.
2. If hydraulic fluid is to be reused, insure the storage containers have been cleaned to avoid contamination.



CAUTION:

DO NOT RE-USE HYDRAULIC FLUID THAT IS CONTAMINATED. THIS WILL CAUSE PUMP FAILURE.

3. Raise the HydraPak and place a container under the hydraulic pump.
4. Remove the tire located on the drain side of the reservoir. Place the container under the drain and remove the plug.
5. Install the drain plug after draining. Use Teflon tape or hydraulic sealant on the threads.
6. Remove hose clamp from suction hose on pump. Note that there will be oil in the hoses and pump. Disconnect hose from pump.
7. Disconnect high pressure hose at pump fitting.
8. Disconnect fittings from pump.
9. Remove socket head cap screws located at pump flange.
10. Remove pump and disconnect coupler from pump.

INSTALLING NEW PUMP

1. Remove the packing cap that holds the key stock in place on the pump shaft.
2. Push the pump coupling onto the pump shaft. Leave a 1/8-inch gap between the coupling and the pump. Tighten the set screw in the coupling against the key stock in the pump shaft. Refer to Figures 1 and 2.

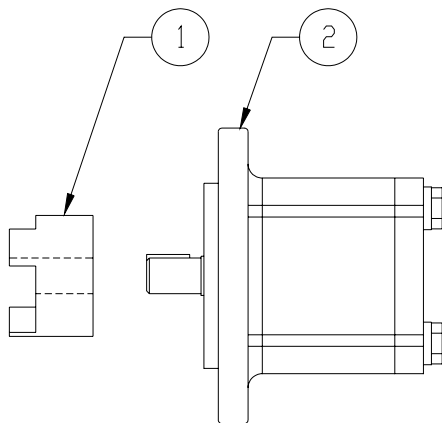

Figure 1

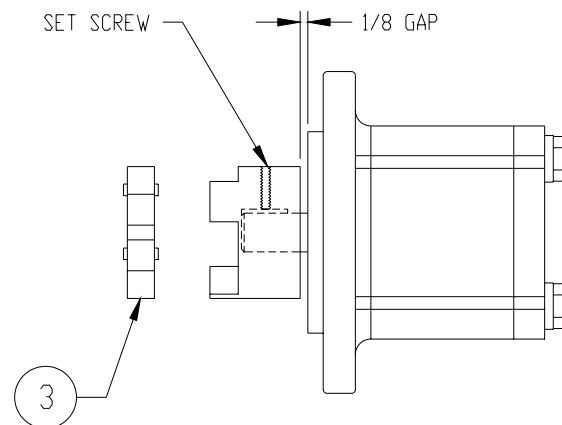

Figure 2

3. Insert the coupling spider onto the pump coupling as shown in Figure 2.
4. Loosen the set screw on the engine coupler. The coupler must slide freely on engine shaft to set the proper clearance between the engine and pump couplers. **Improper clearance will cause pump failure.**
5. Mount the pump to the bracket with the pressure port (small diameter) upwards. Insure the center line of the pump coupler aligns with the center line of the engine coupler. **If these center lines are not aligned, equipment damage can occur.** Fasten the pump in two places using a 3/8-16 X 1-1/4 socket head screw, 3/8 lock washer, and a 3/8 washer. See Figure 3.

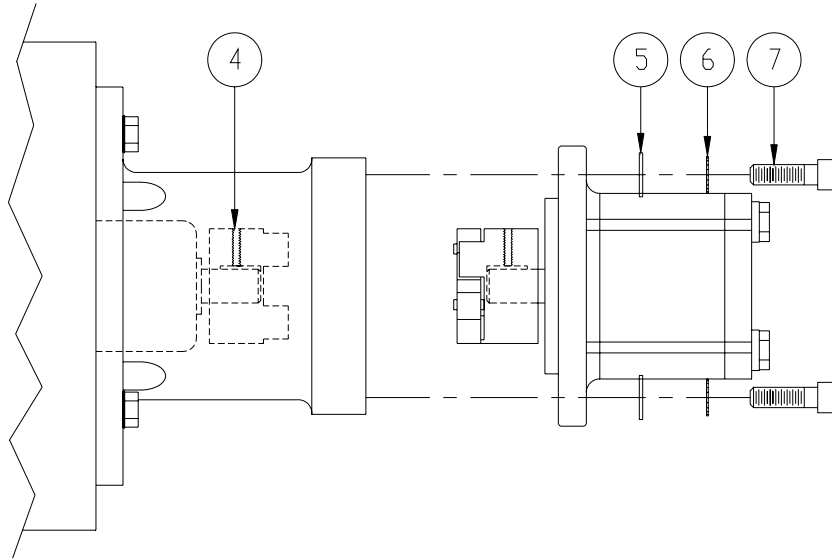

Figure 3

6. Slide the engine coupler towards the pump coupler. Insure the jaws of the coupler engage fully into the spider. Tighten set screw on engine coupler.
7. Install the access cover on the top or “12-clock” access hole of the bracket. See Figure 4.

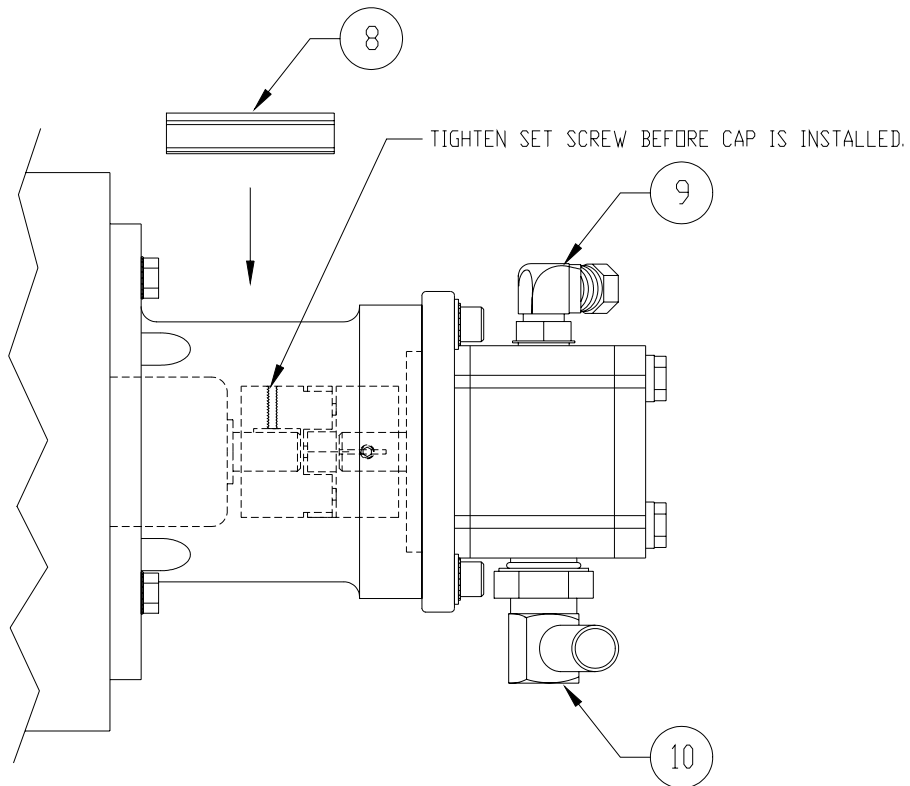

Figure 4

8. Install fittings onto the new pump and hand tighten. Inspect the “O” rings on the fittings and replace if necessary.

9. Connect the low pressure hose to the pump and secure with new hose clamp. Tighten jam nut on fitting. Connect the high pressure hose and tighten. Also, tighten the jam nut. Insure the hoses are not kinked or rubbing against other components.
10. Fill the HydraPak reservoir with hydraulic oil. The fluid level should be one inch from the top of tank. If replacing the oil, Reimann & Georger Corporation uses a Grade ISO VG 32 hydraulic oil.
11. When proceeding to start the HydraPak, always consult the instruction manual. This manual describes procedures that must be followed to insure the safety of all personnel and the proper performance of the equipment.