



# HE1512C ELECTRIC HYDRAPAK INSTRUCTIONS

REIMANN & GEORGER CORPORATION  
CONSTRUCTION PRODUCTS  
P/N 6122048

BUFFALO, NY  
10/05/10

## PRE-OPERATIVE CHECKLIST

This checklist must be checked prior to each use of the HydraPak. This checklist is to be used as a guideline in conjunction with the maintenance and inspection procedures outlined in this manual. The HydraPak and related equipment must be thoroughly inspected prior to each use by a trained person. A trained person is one who has read and thoroughly understands this instruction manual and related equipment manuals and, through training and experience, has shown knowledge regarding the safe operational procedures. If you do not have such a person in your organization, please contact Reimann & Georger Corporation or its distributors and they will assist you in providing such a "trained person." Do not permit any person who is not fully trained to operate this HydraPak or the associated hydraulic tool. It is recommended that this checklist be maintained as a permanent record.

- Insure construction area is secured from all unauthorized personnel.
- All crew members at the construction site must be wearing personal protective equipment as defined by their employer.
- Insure HydraPak has been properly maintained.
- Insure hydraulic heat exchanger is clean and free of obstructions.
- Insure HydraPak is positioned to minimize the amount of construction debris and dust it receives.
- Insure fluid level in hydraulic reservoir is one inch from top.
- Insure the shipping cap has been replaced with the provided chrome filler/breather cap.
- Insure hydraulic hoses are properly connected and in good condition.
- Insure the flow control lever is in the OFF position before starting the HydraPak.
- Insure the power supply is compatible with the motor nameplate ratings.
- Insure the motor rotation direction is correct to arrow on pump bracket.

## TABLE OF CONTENTS

CHAPTER	TITLE	PAGE
<b>1</b>	<b>SAFETY .....</b>	<b>1</b>
1.1	Introduction .....	1
1.2	Safety Definitions .....	1
1.3	HydraPak Safety Labels .....	1
1.4	HydraPak Safety Rules .....	1
<b>2</b>	<b>SPECIFICATIONS .....</b>	<b>3</b>
2.1	Technical Data .....	3
2.2	Recommended Hydraulic Oil .....	3
2.3	Accessories .....	3
2.4	Nameplate and Serial Number Tag .....	4
<b>3</b>	<b>OPERATION .....</b>	<b>5</b>
3.1	Before Operating the HydraPak .....	5
3.1.1	Wiring the Electric Motor .....	5
3.1.2	Checking the Hydraulic System .....	6
3.2	Starting and Operating the HydraPak .....	7
3.3	Stopping the HydraPak .....	8
<b>4</b>	<b>INSPECTION AND MAINTENANCE .....</b>	<b>9</b>
4.1	General Maintenance Rules .....	9
4.2	Hydraulic System Inspection and Maintenance .....	9
4.3	Electrical Inspection and Maintenance .....	10
4.4	Motor Inspection and Maintenance .....	10
4.5	Maintenance Schedule .....	10
<b>5</b>	<b>TROUBLESHOOTING .....</b>	<b>11</b>
<b>6</b>	<b>PARTS LIST .....</b>	<b>14</b>

## LIST OF FIGURES

FIGURE	DESCRIPTION	PAGE
2-1	Typical HydraPak Product Nameplate .....	4
3-1	Motor Starter Wiring .....	6
6-1	HE1512 Assembly Drawing .....	15

# 1 SAFETY

## 1.1 INTRODUCTION

Your Reimann & Georger Corporation HE1512 HydraPak has been engineered to provide performance, long term economics and safety advantages that no other type can match. However, even a well-designed and well-built hydraulic power unit can malfunction or become hazardous in the hands of an inexperienced and/or untrained user. Therefore, read this manual and related equipment manuals thoroughly before operating your HydraPak to provide maximum safety for all operating personnel, and to get the maximum benefit from your equipment.

## 1.2 SAFETY DEFINITIONS

A safety message alerts you to potential hazards that could injure you or others or cause property damage. The safety messages or signal words for product safety signs are **DANGER**, **WARNING**, and **CAUTION**. Each safety message is preceded by a safety alert symbol and is defined as follows:

**DANGER:** Indicates an imminently hazardous situation which, if not avoided, **will** cause death or serious injury. This safety message is limited to the most extreme situations.

**WARNING:** Indicates potentially hazardous situation which, if not avoided, **could** result in death or serious injury.

**CAUTION:** Indicates a potentially hazardous situation which, if not avoided, **may** result in minor or moderate injury. It may also be used to alert against unsafe practices and property-damage-only accidents.

## 1.3 HYDRAPAK SAFETY LABELS

These labels warn you of potential hazards that could cause injury. Read them carefully. If a label comes off or becomes illegible, contact Reimann & Georger Corporation for a free replacement.

## 1.4 HYDRAPAK SAFETY RULES

1. Operators must be thoroughly trained before operating the HydraPak and associated equipment. A trained person is one who has read and thoroughly understands this instruction manual and related equipment manuals and, through training and experience, has shown knowledge regarding the safe operational procedures.
2. Follow the Pre-Operative Checklist before using the equipment.
3. Work area is to be kept clear of unauthorized personnel at all times. Place barricades or secure the area in such a manner that no personnel can be injured.
4. Never use the HydraPak in an explosive atmosphere.
5. Use all personal protective equipment as defined by the employer.
6. Do not use the HydraPak or associated equipment if either shows any signs of damage.
7. Always connect the return (tank) hose connections before the supply (pressure) connections.
8. The supply line for the electric motor must be installed and inspected by a certified electrician in accordance with local electrical codes.
9. Never exceed the flow or pressure for which the hydraulic equipment is rated.
10. Know how to stop the HydraPak quickly in case of emergency.
11. Do not expose HydraPak to water.
12. Never disconnect hydraulic hoses or fittings while the HydraPak is running.

13. Do not adjust the HydraPak while it is running.
14. Never adjust or service the associated hydraulic equipment during operation or while connected to the HydraPak.
15. Keep all clothing and all body parts clear of moving parts.
16. Always turn the hydraulic flow off before connecting or disconnecting the hydraulic hoses.
17. At end of operation, secure the HydraPak and the associated hydraulic equipment to prevent unauthorized use. Never assume you will find the equipment in the same condition in which you left it.
18. Only trained personnel are authorized to do repairs.
19. Do not use the HydraPak or associated hydraulic equipment when you are tired or fatigued.
20. Do not operate HydraPak or associated hydraulic equipment when under the influence of drugs, alcohol, or medication.

## 2 SPECIFICATIONS

### 2.1 TECHNICAL DATA

Electric Motor	15 hp Baldor
Volts	208–230
Full Load Amps	39amps(@2000psi)
Speed (rpm)	3450
Hertz	60
Phase	3
Weight:	345 lbs.
Hydraulic System:	Open Center
Pressure Settings	1750, 2000, 2500 psi
Back Pressure	<100 psi @ 12 GPM
Reservoir	6 U.S. gallons—shipping cap and vented fill cap provided
Pump Type	Positive Displacement Gear
Flow Settings	0-12 GPM
Cooling Capacity	16,000 BTU/hr.
Couplings	1/2" HTMA Flush Face
Filter	10 micron
Suction Screen	10 mesh
Filler/Breather	100 mesh
Electrical:	
AC / DC Converter	2 AMP
Fan Fuse (blade type)	Automotive 25 AMP
Tires:	
Size	16 x 6.50-8
Inflation	14 psi

NOTE: 1750 & 2000 psi continuous duty, 2500psi intermittent duty.

### 2.2 RECOMMENDED HYDRAULIC OIL

Many types of compatible hydraulic oil are available through your local dealer/distributor. As an original equipment manufacturer, RGC uses a Grade ISO VG 32 hydraulic oil.

Extreme weather conditions or operating environments may require using a different viscosity oil or fluid type than what is provided. If you have any question concerning the type of oil suitable for HE1512 operation, please consult your local supplier or Reimann & Georger Corporation for details.

### 2.3 ACCESSORIES

A motor starter and the following are supplied as standard equipment:

1. **Hour Meter**—Allows for timely scheduled maintenance of equipment.
2. **Hydraulic Pressure Gauge**—Monitors operating pressures.
3. **Volt Meter**—Indicates DC power supply is being maintained.
4. **Wide Tires**—Provide increased stability on rough terrain.

## 2.4 NAMEPLATE AND SERIAL NUMBER TAG

It is important to identify your HydraPak completely and accurately whenever ordering spare parts or requesting assistance in service. The HydraPak has a product nameplate that shows the model and serial numbers as shown in Figure 2-1. Record the model and serial numbers for future reference.



**Figure 2-1.**  
**Typical HydraPak Product Nameplate**

**MODEL** \_\_\_\_\_ **HE1512** \_\_\_\_\_

**SERIAL NUMBER** \_\_\_\_\_

## 3 OPERATION

### 3.1 BEFORE OPERATING THE HYDRAPAK



#### **WARNING:**

**ONLY TRAINED PERSONNEL SHALL OPERATE THIS EQUIPMENT. A TRAINED PERSON IS ONE WHO HAS READ AND THOROUGHLY UNDERSTANDS THIS INSTRUCTION MANUAL AND RELATED EQUIPMENT MANUALS AND, THROUGH TRAINING AND EXPERIENCE, HAS SHOWN KNOWLEDGE REGARDING THE SAFE OPERATIONAL PROCEDURES.**



#### **WARNING:**

**FOLLOW THE PRE-OPERATIVE CHECKLIST IN THE FRONT OF THIS MANUAL BEFORE OPERATING.**



#### **WARNING:**

**DO NOT USE IN WET CONDITIONS.**



#### **CAUTION:**

**USE THE HYDRAPAK WITH OPEN-CENTER TOOLS ONLY.**

1. Thoroughly read the motor and associated hydraulic equipment instruction manuals for complete safety, operating and maintenance information before operating.
2. Obey all the safety labels provided on your hydraulic tool and HydraPak. These labels warn you of potential hazards that can cause death or serious injury. If a label comes off or becomes hard to read, contact Reimann & Georger Corporation for replacement information.
3. Construction area is to be kept clear of unauthorized personnel. Place barricades or secure the area in such a manner that no personnel can be injured.
4. Position the HydraPak to minimize the amount of construction debris and dust it receives.

#### **3.1.1. Wiring the Electric Motor**



#### **CAUTION:**

**IF 440V SERVICE IS REQUIRED, DO NOT REWIRE THE MOTOR WITHOUT FIRST CONSULTING THE FACTORY.**

1. The 15 HP motor is wired for 208–230V, 60 Hertz, 3 phase.
2. The supplied motor starter is wired as shown in Figure 3-1. An electrical plug end must be installed on the cord by a qualified electrician. Insure the power supply is compatible with the motor nameplate ratings.
3. Check motor rotation to decal on pump bracket by jogging the motor. If motor runs backwards, switch wires L1 and L3. Operating the motor in the wrong direction will damage the hydraulic pump and cause equipment failure.

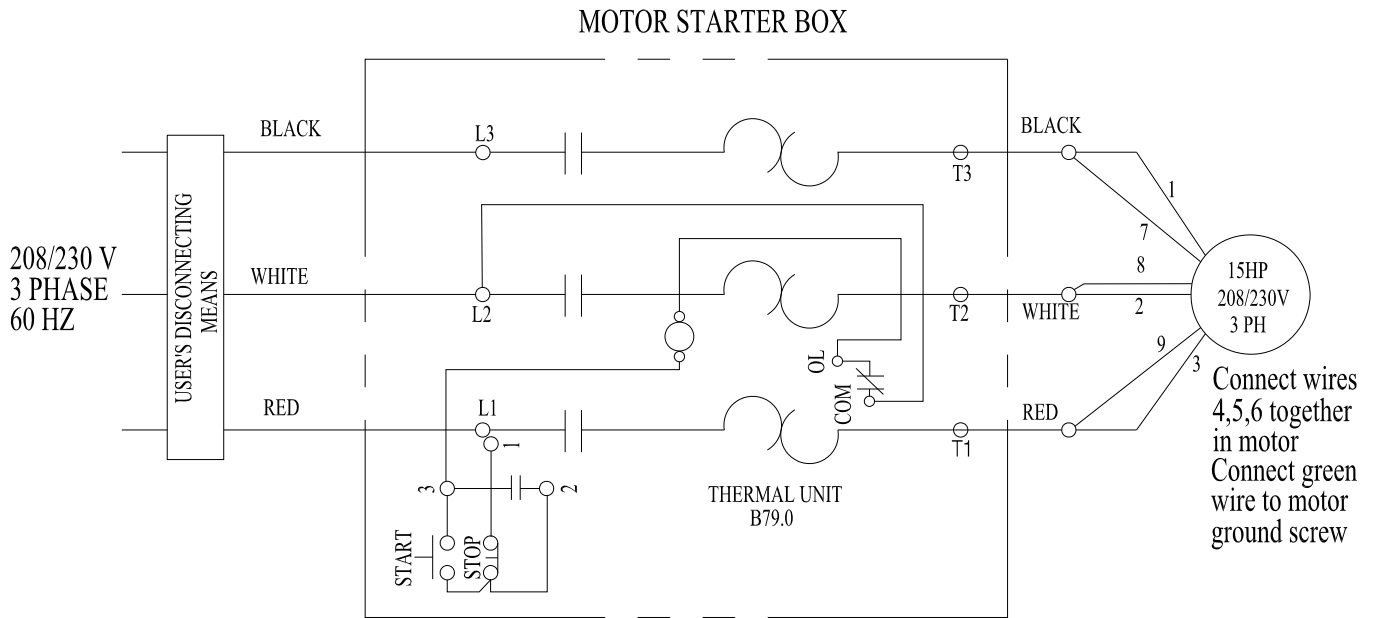

Check motor direction to arrow on pump bracket to reverse direction switch wires L1 and L3.

**Figure 3-1.**  
**Motor Starter Wiring**

4. When wiring the motor, use the following wire sizing chart ONLY as a guide.

**WIRE SIZING GUIDE  
FOR REFERENCE ONLY**

Distance → Motor rating ↓	50 feet	100 feet	150 feet	200 feet
230 V, 40 amp	#8 awg	#6 awg	#6 awg	#6 awg

awg = American Wire Gauge  
amp = Motor Full Load Current  
feet = Distance From MAIN Breaker Box to Control Panel



**WARNING:**

**THE ABOVE CHART IS ONLY A REFERENCE FOR WIRE SIZING. YOU MUST CONSULT A QUALIFIED ELECTRICIAN TO DETERMINE THE ACTUAL WIRE SIZE REQUIRED TO SUIT YOUR PARTICULAR APPLICATION AND ELECTRIC CODE.**

**3.1.2 Checking the Hydraulic System**

1. Check hydraulic reservoir as follows.
  - a. Replace the shipping cap with the chrome filler/breather cap provided.
  - b. Fluid level should be one inch from the top of tank.
2. Before making any hydraulic connections, inspect all hydraulic lines, fittings and hoses for leaks and risks of rupture as follows:

- a. Inspect each hydraulic line, fitting, and hose for breaks, cracks, worn spots, bulges, chemical attack, kinks or any other damage. Never try to stop any detected leak with any body parts. Do not put your face close to suspected leaks. Hold a piece of cardboard close to suspected leaks and then inspect the cardboard for signs of hydraulic oil.
- b. Replace a damaged line, fitting or hose immediately. Never repair the part.



**WARNING:**

**LIQUID UNDER HIGH PRESSURE CAN PIERCE THE SKIN, CAUSING DEATH OR SERIOUS INJURY. IN CASE OF INJURY, GET IMMEDIATE MEDICAL ATTENTION.**

3. The HydraPak uses flush-face quick-release couplings that are durable and easy to clean. Wipe the mating surfaces of the couplings with a clean rag prior to making connection. They are always fitted such that the male coupling supplies oil and the female coupling receives oil.
  - a. Connect the return (tank) line from the HydraPak return port to the return port of the hydraulic tool.
  - b. Then connect the pressure line from the hydraulic tool pressure port to the upper (pressure) port on the HydraPak.
  - c. When making connections, do not over stretch the hoses or bend them at a sharp angle.



**WARNING:**

**ENSURE HYDRAULIC HOSES ARE PROPERLY CONNECTED AND IN GOOD CONDITION.**

### **3.2 STARTING AND OPERATING THE HYDRAPAK**

1. Turn the pressure control lever to the relief setting that is closest to, but does not exceed, the hydraulic tool's specification.
2. Insure the flow control lever is in the OFF position before starting.
3. Before starting the motor, insure that it has been properly wired as detailed in Section 3.1.1.
4. Insure the AC/DC converter switch is in the ON position. If this switch is turned off, the 12V fan will not start and cause system overheating. When the motor is started, the fan will automatically start and remain running as long as the motor starter switch is on.
5. After starting the motor, use the flow control lever to select the GPM setting in accordance with your hydraulic tool instruction manual. Do not exceed the recommended flow and pressure for the hydraulic tool in use. Know how to stop your HydraPak quickly in case of emergency.



**WARNING:**

**WHEN OPERATING THE HYDRAPAK, OBSERVE ALL SAFETY PRECAUTIONS DESCRIBED IN THE HYDRAPAK AND HYDRAULIC TOOL INSTRUCTION MANUALS. FAILURE TO COMPLY COULD RESULT IN DEATH, SERIOUS INJURY AND/OR EQUIPMENT DAMAGE.**

6. Do NOT attempt to make any equipment adjustments during operation.

### **3.3 STOPPING THE HYDRAPAK**

At the end of operation, secure the equipment to prevent unauthorized use. Never assume you will find the equipment in the same condition that you left it. Proceed as follows:

1. Let the motor run for about five (5) minutes to cool hydraulic oil and components, or for ten (10) minutes under severe operating conditions.
2. Turn the flow control lever to the OFF position.
3. Shut off the HydraPak motor.
4. Disconnect the power supply line.

## 4 INSPECTION AND MAINTENANCE

### 4.1 GENERAL MAINTENANCE RULES

1. Proper maintenance of the HydraPak and related hydraulic equipment consists of adhering to all the guidelines given in this chapter and in the Pre-Operative Checklist in the front of this manual. Proper maintenance is required to maintain the system in good condition, which is defined as each part being free of damage or functional defects.
2. Review and follow all the safety rules given in Chapter 1 before attempting any maintenance.
3. Only authorized personnel should be allowed in the maintenance area. Authorized personnel are the trained people as defined below and their supervision.
4. Repairs must be made only by trained personnel. A trained person is one who has read and thoroughly understands this instruction manual and related equipment manuals and, through training and experience, has shown knowledge regarding the safe operational procedures.
5. All authorized maintenance personnel must wear the appropriate personal protective equipment as defined by their employer.



#### **WARNING:**

**BEFORE STARTING ANY MAINTENANCE ON THE HYDRAPAK, DISCONNECT THE ELECTRIC POWER SOURCE AND LOCK IT OUT TO PREVENT ACCIDENTAL STARTUP.**



#### **WARNING:**

**DO NOT ADJUST OR REMOVE HYDRAULIC COMPONENTS, LINES, OR FITTINGS WHILE THE HYDRAPAK IS RUNNING OR WHENEVER THE HYDRAULIC FLUID IS HOT.**



#### **WARNING:**

**LIQUID UNDER HIGH PRESSURE CAN PIERCE THE SKIN, CAUSING DEATH OR SERIOUS INJURY. IN CASE OF INJURY, GET IMMEDIATE MEDICAL ATTENTION.**

### 4.2 HYDRAULIC SYSTEM INSPECTION AND MAINTENANCE

1. Check to see that the hydraulic fluid is clean, and change oil and filter at recommended intervals to extend the life of the HydraPak. Refer to the maintenance summary in Section 4.5.
2. Clean debris from heat exchanger daily.
3. Before making any hydraulic connections, inspect all hydraulic lines, fittings and hoses for leaks and risks of rupture as follows:
  - a. Inspect each hydraulic line, fitting, and hose for breaks, cracks, worn spots, bulges, chemical attack, kinks or any other damage. Never try to stop any detected leak with any body parts. Do not put your face close to suspected leaks. Hold a piece of cardboard close to suspected leaks and then inspect the cardboard for signs of hydraulic oil.
  - b. Replace a damaged line, fitting or hose immediately. Never repair the part.
4. The HydraPak uses flush-face quick-release couplings that are durable and easy to clean. Wipe the mating surfaces of the couplings with a clean rag prior to making connection. They are always fitted such that the male coupling supplies oil and the female coupling receives oil.

### 4.3 ELECTRICAL INSPECTION AND MAINTENANCE

The electrical system requires the following visual inspections before each use of the HydraPak:

1. Fuses must be secured in their holders.
2. All terminal connections must be intact.
3. Insure the fan blade is clean and free to rotate.

### 4.4 MOTOR INSPECTION AND MAINTENANCE

Grease electric motor fittings once a year to lubricate internal bearings.

### 4.5 MAINTENANCE SCHEDULE

The following table summarizes the type and frequency of maintenance required. Follow the manufacturer's instructions for detailed maintenance. For repairs, contact the nearest authorized service center.

TYPE OF MAINTENANCE	FREQUENCY OF SERVICE
Check and clean obstruction from heat exchanger *	Daily
Check that reservoir oil level is within one inch below filler cap—add if required	Daily
Check that hydraulic oil is clean	Daily
Check and clean obstructions from cooling fins and external surfaces	100 hrs.
Replace reservoir filter and oil after first 50 hrs. **	250 hrs.
Clean suction screen in reservoir	250 hrs.
Check coupling spider	250 hrs.
Grease wheel bearings	500 hrs.

\* The hydraulic heat exchanger must always be kept clean and free of obstructions. Check it daily before operating and frequently during use. If debris builds up on the screen during operation, remove debris as soon as it is safely possible.



#### **CAUTION:**

**AN OBSTRUCTED HEAT EXCHANGER WILL CAUSE THE HYDRAULIC SYSTEM TO OVERHEAT AND FAIL PREMATURELY.**

\*\* Change more often under heavy duty, high temperature applications. When draining the oil, clean filler/breather cap and replace if damaged.

## 5 TROUBLESHOOTING

The following chart is intended to assist with troubleshooting the HE1512 HydraPak. While not all inclusive, the chart outlines the most common causes of a problem and the recommended course of action.

The troubleshooting guide for the associated hydraulic tool is in the manual specifically for this equipment.



**CAUTION:**

**IF THE PROBLEM WITH THE MOTOR IS NOT CERTAIN, ALWAYS FOLLOW THE MANUFACTURER'S WARRANTY POLICY BEFORE ANY OTHER REPAIR OR MAINTENANCE IS ATTEMPTED.**

SYMPTOM	CAUSE AND CORRECTIVE ACTION
Electric motor won't start.	<p>Motor wired improperly—do NOT tamper with either the electrical supply or the power line connections at either the motor or the main breaker. Consult a licensed electrical contractor.</p> <p>Blown fuse or tripped circuit breaker—replace or reset as required.</p> <p>Faulty switch—replace switch.</p>
Motor is blowing heaters in the starter box upon startup.	<p>Motor is drawing excess amperage because flow control lever is not OFF—turn to OFF position.</p> <p>Motor is wired improperly—do NOT tamper with either the electrical supply or the power line connections at either the motor or the main breaker. Consult a licensed electrical contractor.</p>
HydraPak won't operate hydraulic tool—motor operating normally.	<p>Low fluid level in reservoir—fill to required level.</p> <p>Flow restriction caused by:</p> <ol style="list-style-type: none"> <li>a. Kinked or damaged hose</li> <li>b. Pinched or damage steel line</li> <li>c. Poor connection in either a hose or steel line.</li> </ol> <p>Coupling between motor and pump damaged—replace the following items as required:</p> <ol style="list-style-type: none"> <li>a. Coupling spider worn out</li> <li>b. Pump or motor key sheared.</li> </ol> <p>No hydraulic oil pressure caused by:</p> <ol style="list-style-type: none"> <li>a. Flow control lever off—if no flow is selected, there can be no pressure.</li> <li>b. Pressure control lever set too low—check hydraulic tool requirement and adjust accordingly</li> <li>c. Air in fluid—inspect for oil leaks and repair to correct.</li> </ol> <p>No hydraulic oil flow caused by:</p> <ol style="list-style-type: none"> <li>a. Flow control lever off—adjust flow control.</li> <li>b. Hose disconnected—check hose connections.</li> <li>c. Coupling key sheared—inspect and replace.</li> <li>d. Damaged pump—inspect and replace.</li> </ol> <p>Pump or motor defective—contact the nearest authorized service center.</p>

HydraPak won't operate hydraulic tool—motor operating normally (continued)	Inadequate electric power source leading to motor failure or blown fuses on low voltage—if the power source and motor rating are not compatible, consult a licensed electrician.
HydraPak is operating hydraulic tool slowly or erratically—motor operating normally.	<p>Hydraulic tool is being overloaded when working on the construction medium—check hydraulic tool specifications and reduce load on tool as required.</p> <p>Low fluid level in reservoir—fill to required level.</p> <p>One or more of the following flow restrictions:</p> <ol style="list-style-type: none"> <li>a. Hose kinked or damaged</li> <li>b. System filter clogged—fluid going through bypass.</li> <li>c. Suction filter clogged—fluid going through bypass.</li> <li>d. Steel line pinched or damaged.</li> <li>e. Heat exchanger clogged—overheating system.</li> </ol> <p>Electric motor extension cord improperly sized which can cause reduced voltage input.</p> <p>Erratic pressure caused by:</p> <ol style="list-style-type: none"> <li>a. Contamination in fluid—drain fluid, then inspect and replace filters and fluid.</li> <li>b. Air in fluid—inspect for oil leaks and repair to correct.</li> </ol> <p>Oil viscosity too heavy for cold climate—contact your local supplier or Reimann &amp; Georger Corporation for information.</p> <p>System relief valve malfunctioning:</p> <ol style="list-style-type: none"> <li>a. Set too low for application.</li> <li>b. Stuck partially open</li> <li>c. Has broken spring.</li> </ol> <p>Pump or motor damaged or worn—contact your nearest authorized service center.</p> <p>Extension hoses too long:</p> <ol style="list-style-type: none"> <li>a. Hoses over 50 feet long add sufficient friction to the hydraulic system to slow down the hydraulic tool slightly.</li> <li>b. Where possible, use as few quick disconnects as possible.</li> <li>c. An increase in system pressure may be required to compensate for long hose runs. Consult your local supplier or Reimann &amp; Georger Corporation for information.</li> </ol> <p>Hydraulic oil flow set too low—increase flow using the 0-10 gpm control lever. Do not exceed tool specifications.</p> <p>Hydraulic pressure relief set too low—readjust using the 1750/2000/2500-psi control lever.</p>
System overheats—motor operating normally.	<p>Low fluid level in reservoir—fill to required level.</p> <p>Air intake of heat exchanger clogged/dirty.</p> <p>Air in fluid—inspect for oil leaks and repair to correct.</p>
System overheats—motor operating normally	Severe operating conditions caused by:

(continued).	<ul style="list-style-type: none"> <li>a. Extremely high ambient temperature-- use a higher viscosity hydraulic oil. Consult your local supplier or Reimann &amp; Georger Corporation for details.</li> <li>b. Extended duty cycle—operate HydraPak intermittently to provide cooling periods</li> </ul> <p>Heat exchanger not functioning efficiently because:</p> <ul style="list-style-type: none"> <li>a. Air intake or internal parts of heat exchanger clogged/dirty—clear debris as required.</li> <li>b. Fan is not running—see detailed troubleshooting guide below.</li> </ul> <p>Fan is not running because:</p> <ul style="list-style-type: none"> <li>a. AC/DC converter switch is in OFF position—switch must be turned ON to operate the fan.</li> <li>b. Fan connection unplugged—check and secure all fan plug connections at fan motor, fan relay, and at any fan override switch on control panel.</li> <li>c. Blown fuse in fan circuit—replace with specified fuse.</li> <li>d. Defective relay—replace.</li> </ul>
Hydraulic tool is overspeeding	Flow is set too high—set to tool specifications on the 0-10 gpm control lever.
Oil is foaming.	<p>Low fluid level in reservoir—fill to required level.</p> <p>Water in oil.</p> <p>Pump shaft seal worn out causing air to be drawn into pump.</p> <p>Air leak in suction line.</p> <p>Improper type of hydraulic oil--as an original equipment manufacturer, RGC uses a Grade ISO VG 32 hydraulic oil. If you have any questions concerning the type of oil you should use for your HydraPak, consult your local supplier or RGC for details.</p>
Pump leaks.	<p>Shaft seal worn on pump.</p> <p>Cracked inlet/outlet fitting.</p>
One or more meters are malfunctioning.	<p>Loose or broken connection—repair or replace as required.</p> <p>Electrical problem with meter— contact your local supplier or Reimann &amp; Georger Corporation for information.</p>
Problem with split frame reassembly	Misalignment of top/bottom halves—align and assemble using grease to lube four frame telescoping sleeves, then secure with appropriate hardware.

## 6 PARTS LIST

The following parts list applies to the HE1512C HydraPak only. Each item number on this parts list can be matched with the item number shown on the Figure 6-1 assembly drawing.

Item Number	Part Number	Quantity	Description
1	2546004	1	MAIN FRAME
2	2565151	1	MOTOR 15 HP 230V
3	5401505	1	AC/DC POWER SUPPLY
4	5410116	2	FUSE 6 AMP FOR AC/DC CONVERTER
5	2510872	1	RESERVOIR
6	6000921	1	FILLER BREATHER CAP
7	6000908	1	SUCTION STRAINER ASSY
8	5800138	4	CLEVIS PIN ROUNDED SNAP
9	2546006	1	FRAME HANDLE
10	6001885	1	COUPLING 1/2" MALE
11	6001886	1	COUPLING 1/2" FEMALE
12	5401560	1	WIRE HARNESS
13	2514301	1	HEAT EXCHANGER ASSY
14	6010855	1	HEAT EXCHANGER CORE
15	5411513	1	FAN 12"
16	5800387	2	COTTER HAIR PIN
17	6901504	1	HYDRAULIC PUMP
18	6901502	1	PUMP COVER
19	6901503	1	PUMP BRACKET
20	6500187	1	STARTER BOX
20	5415122	3	HEATER ELEMENT
20	5400189	1	SWITCH START-STOP
21	5701570	1	VOLT METER
22	5701972	1	PRESSURE GAGE
23	5701571	1	HOUR METER
24	6225423	1	CONTROL PANEL DECAL
24	2501540	1	CONTROL PANEL
25	7601523	2	TIRE AND RIM ASSY—WIDE
26	6004723	1	HYDRAULIC FILTER ELEMENT
27	6000904	1	HYDRAULIC FILTER ASSY
28	6004722	1	HYDRAULIC FILTER HEAD
29	2501524	1	AXLE—WIDE TIRE
30	6704795	1	COUPLING HALF PUMP 1/2"
31	6704798	1	COUPLING INSERT
32	6700839	1	COUPLING HALF MOTOR 1-3/8"
33	6015308	3	RELIEF VALVE
34	6015306	1	PILOT LOGIC ELEMENT
35	6015305	1	CHECK VALVE
36&37	6085401	1	FLOW CONTROL VALVE & HANDLE ASSY 10 POSITION
38	6061132	2	HANDLE ONLY FOR 3 POSITION & 10 POSITION ASSY'S
39	6015304	1	PRESSURE CONTROL HANDLE ASSY 3 POSITION
40	6015303	1	PRESSURE CONTROL VALVE

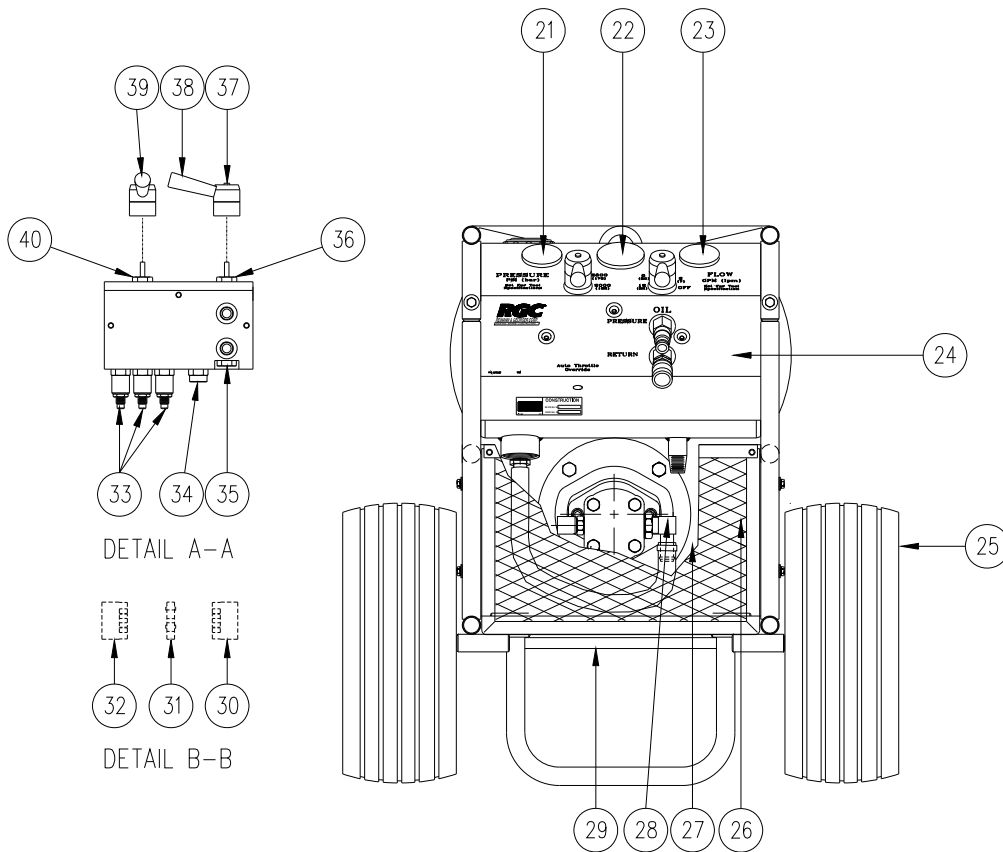
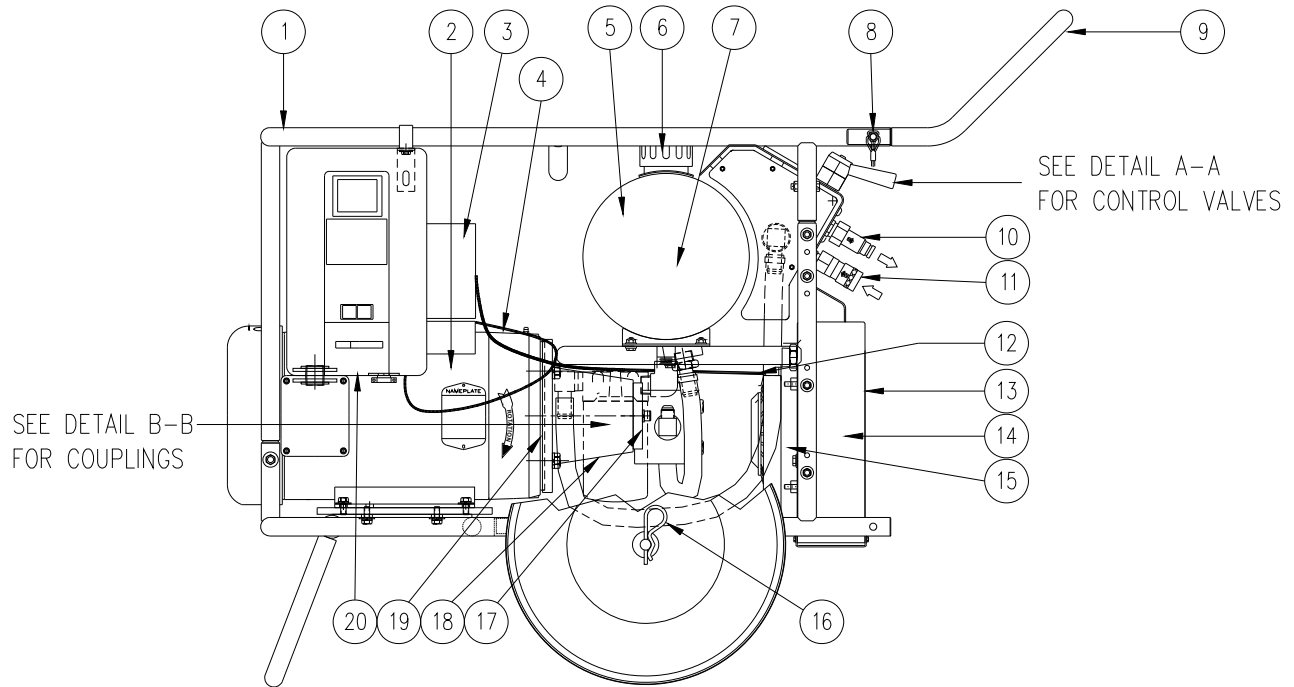

**Figure 6-1.**  
**HE1512 Assembly Drawing**

## **LIMITED PRODUCT WARRANTY**

**Reimann & Georger Corporation  
Hoisting and Construction Products**

### **A. LIMITED WARRANTY**

Reimann & Georger Corporation (the “Manufacturer”) warrants to the original purchaser (the “Buyer”) that all Reimann & Georger Hoisting and Construction products shall be free of defects in material and workmanship for a period of one (1) year from date of original purchase.

### **B. MANUFACTURER’S OBLIGATIONS**

The Manufacturer’s sole obligation under this Limited Warranty is the repair or, at the Manufacturer’s discretion, the replacement of parts found to be defective. Parts and equipment must have authorization from the Manufacturer prior to return to the Manufacturer or repair by an authorized service person. Costs of transportation and other expenses connected with replacing or repairing parts are not covered under this Limited Warranty.

### **C. PARTS MANUFACTURED BY OTHERS**

This Limited Warranty does not cover any parts manufactured by others. Such parts are subject to the warranty, if any, of their respective manufacturers, and are to be repaired only by a respective authorized service person for such parts. The Manufacturer shall have no obligation to undertake repairs of parts manufactured by others.

### **D. NO SPECIAL, INCIDENTAL, OR CONSEQUENTIAL DAMAGES**

**IN NO EVENT SHALL THE MANUFACTURER BE LIABLE TO THE BUYER OR ANY OTHER PERSON FOR ANY INDIRECT, SPECIAL, INCIDENTAL OR CONSEQUENTIAL LOSSES OR DAMAGES CONNECTED WITH THE USE OF THE PRODUCT UNDER THIS LIMITED WARRANTY. SUCH DAMAGES FOR WHICH THE MANUFACTURER SHALL NOT BE RESPONSIBLE INCLUDE, BUT ARE NOT LIMITED TO, LOST TIME AND CONVENIENCE, LOSS OF USE OF THE PRODUCT, THE COST OF A PRODUCT RENTAL, COSTS OF GASOLINE, TELEPHONE, TRAVEL, OR LODGING, THE LOSS OF PERSONAL OR COMMERCIAL PROPERTY, AND THE LOSS OF REVENUE.**

### **E. NO LIABILITY IN EXCESS OF PURCHASE PRICE**

**IN NO EVENT SHALL THE MANUFACTURER’S OBLIGATIONS UNDER THIS LIMITED WARRANTY EXCEED THE PURCHASE PRICE OF THE PRODUCT.**

### **F. NO EXTENSION OF STATUTE OF LIMITATIONS**

**ANY REPAIRS PERFORMED UNDER THIS WARRANTY SHALL NOT IN ANY WAY EXTEND THE STATUTES OF LIMITATIONS FOR CLAIMS UNDER THIS LIMITED WARRANTY.**

### **G. WAIVER OF OTHER WARRANTIES**

**THE EXPRESS WARRANTIES SET FORTH IN THIS LIMITED WARRANTY ARE IN LIEU OF AND EXCLUDE ANY AND ALL OTHER WARRANTIES, EXPRESS OR IMPLIED, INCLUDING, BUT NOT LIMITED TO, THE IMPLIED WARRANTIES OR MERCHANTABILITY AND FITNESS FOR A PARTICULAR PURPOSE.**

### **H. PROCEDURE FOR WARRANTY PERFORMANCE**

If the product fails to perform to the Manufacturer’s specifications, the Buyer must provide the Manufacturer with the applicable model and serial numbers, the date of purchase, and the nature of the problem.

**I. ADDITIONAL EXCLUSIONS FROM THIS LIMITED WARRANTY. THIS LIMITED WARRANTY DOES NOT COVER ANY OF THE FOLLOWING:**

1. Equipment which has been abused, damaged, used beyond rated capacity, or repaired by persons other than authorized service personnel.
2. Damage caused by acts of God which include, but are not limited to, hailstorms, windstorms, tornadoes, sandstorms, lightning, floods, and earthquakes.
3. Damage under conditions caused by fire or accident, by abuse or by negligence of the user or any other person other than the Manufacturer, by improper installation, by misuse, by incorrect operation, by "normal wear and tear", by improper adjustment or alteration, by alterations not completed by authorized service personnel, or by failure of product parts from such alterations.
4. Costs of repairing damage caused by poor or improper maintenance, costs of normally scheduled maintenance, or the cost of replacing any parts unless done as the result of an authorized repair covered by the one (1) year Limited Warranty.
5. Costs of modifying the product in any way once delivered to the Buyer, even if such modifications were added as a production change on other products made after the Buyer's product was built.

**J. NO AUTHORITY TO ALTER THIS LIMITED WARRANTY**

No agent, representative, or distributor of the Manufacturer has any authority to alter the terms of this Limited Warranty in any way.