



# **HV1810STD/HV1810XL BI-DIRECTIONAL HYDRAPAK INSTRUCTIONS**

**REIMANN & GEORGER CORPORATION  
CONSTRUCTION PRODUCTS  
P/N 6122022**

**BUFFALO, NY  
09/25/08**

## PRE-OPERATIVE CHECKLIST

This checklist must be checked prior to each use of the HydraPak. This checklist is to be used as a guideline in conjunction with the maintenance and inspection procedures outlined in this manual. The HydraPak and related equipment must be thoroughly inspected prior to each use by a trained person. A trained person is one who has read and thoroughly understands this instruction manual and related equipment manuals and, through training and experience, has shown knowledge regarding the safe operational procedures. If you do not have such a person in your organization, please contact Reimann & Georger Corporation or its distributors and they will assist you in providing such a “trained person.” Do not permit any person who is not fully trained to operate this HydraPak or the associated hydraulic tool. It is recommended that this checklist be maintained as a permanent record.

- Insure construction area is secured from all unauthorized personnel.
- All crew members at the construction site must be wearing personal protective equipment as defined by their employer.
- Insure HydraPak has been properly maintained.
- Insure flammable storage is at least ten feet from HydraPak.
- Insure hydraulic heat exchanger is clean and free of obstructions.
- Insure HydraPak is located in a well ventilated area.
- Insure HydraPak is positioned to minimize the amount of construction debris and dust it receives.
- Insure engine oil level is full.
- Insure fluid level in hydraulic reservoir is one inch from top.
- Insure the shipping cap has been replaced with the provided chrome filler/breather cap.
- Insure hydraulic hoses are properly connected and in good condition.
- Insure the flow control lever is in the OFF position before starting the HydraPak.

## TABLE OF CONTENTS

CHAPTER	TITLE	PAGE
<b>1</b>	<b>SAFETY .....</b>	<b>1</b>
1.1	Introduction .....	1
1.2	Safety Definitions .....	1
1.3	HydraPak and Tool Safety Labels .....	1
1.4	HydraPak Safety Rules .....	1
<b>2</b>	<b>SPECIFICATIONS .....</b>	<b>3</b>
2.1	Technical Data .....	3
2.2	HV1810XL Options .....	3
2.3	Recommended Hydraulic Oil .....	3
2.4	Nameplate and Serial Number Tag .....	4
<b>3</b>	<b>OPERATION .....</b>	<b>5</b>
3.1	Before Operating the HydraPak .....	5
3.1.1	Checking the Engine .....	5
3.1.2	Checking the Hydraulic System .....	5
3.2	Starting and Operating the HydraPak .....	6
3.3	Stopping the HydraPak .....	7
<b>4</b>	<b>INSPECTION AND MAINTENANCE .....</b>	<b>8</b>
4.1	General Maintenance Rules .....	8
4.2	Hydraulic System Inspection and Maintenance .....	8
4.3	Electrical Inspection and Maintenance .....	9
4.4	Engine Inspection and Maintenance .....	9
4.5	Maintenance Schedule .....	10
<b>5</b>	<b>TROUBLESHOOTING .....</b>	<b>11</b>
<b>6</b>	<b>PARTS LIST .....</b>	<b>15</b>

## LIST OF FIGURES

FIGURE	DESCRIPTION	PAGE
2-1	Typical HydraPak Product Nameplate .....	4
6-1	HV1810 Assembly Drawing .....	16

# 1 SAFETY

## 1.1 INTRODUCTION

Your Reimann & Georger Corporation HV1810STD / HV1810XL BI-Directional HydraPaks have been engineered to provide performance, long term economics and safety advantages that no other type can match. However, even a well-designed and well-built hydraulic power unit can malfunction or become hazardous in the hands of an inexperienced and/or untrained user. Therefore, read this manual and related equipment manuals thoroughly before operating your HydraPak to provide maximum safety for all operating personnel, and to get the maximum benefit from your equipment.

## 1.2 SAFETY DEFINITIONS

A safety message alerts you to potential hazards that could injure you or others or cause property damage. The safety messages or signal words for product safety signs are **DANGER**, **WARNING**, and **CAUTION**. Each safety message is preceded by a safety alert symbol and is defined as follows:

**DANGER:** Indicates an imminently hazardous situation which, if not avoided, **will** cause death or serious injury. This safety message is limited to the most extreme situations.

**WARNING:** Indicates potentially hazardous situation which, if not avoided, **could** result in death or serious injury.

**CAUTION:** Indicates a potentially hazardous situation which, if not avoided, **may** result in minor or moderate injury. It may also be used to alert against unsafe practices and property-damage-only accidents.

## 1.3 HYDRAPAK AND TOOL SAFETY LABELS

These labels warn you of potential hazards that could cause injury. Read them carefully. If a label comes off or becomes illegible, contact Reimann & Georger Corporation for a free replacement.

## 1.4 HYDRAPAK SAFETY RULES

1. Operators must be thoroughly trained before operating the HydraPak and associated equipment. A trained person is one who has read and thoroughly understands this instruction manual and related equipment manuals and, through training and experience, has shown knowledge regarding the safe operational procedures.
2. Follow the Pre-Operative Checklist before using the equipment.
3. Do not use the HydraPak or associated equipment if either shows any signs of damage.
4. Never use the HydraPak in an explosive atmosphere and/or near combustible material that could be ignited by a spark.
5. Work area is to be kept clear of unauthorized personnel at all times. Place barricades or secure the area in such a manner that no personnel can be injured.
6. Use all personal protective equipment as defined by the employer.
7. Keep all clothing and all body parts clear of moving parts.
8. Always connect the return (tank) hose connections before the supply (pressure) connections.
9. Never exceed the flow or pressure for which the hydraulic equipment is rated.
10. Use an approved fuel container in a well-ventilated area when refueling. Move fuel container at least ten feet from fueling point before starting.
11. Operate the HydraPak in a well-ventilated area.
12. Do not touch a hot muffler, engine cylinder, or fins.

13. Do not adjust the HydraPak while it is running.
14. Never adjust or service the associated hydraulic equipment during operation or while connected to the HydraPak.
15. Know how to stop the HydraPak quickly in case of emergency.
16. Allow engine to cool two minutes before refueling.
17. Never disconnect hydraulic hoses or fittings while the HydraPak is running.
18. At end of operation, secure the HydraPak and the associated hydraulic equipment to prevent unauthorized use. Never assume you will find the equipment in the same condition in which you left it.
19. Only trained personnel are authorized to do repairs.
20. Do not use the HydraPak or associated hydraulic equipment when you are tired or fatigued.
21. Do not operate HydraPak or associated hydraulic equipment when under the influence of drugs, alcohol, or medication.

## 2 SPECIFICATIONS

### 2.1 TECHNICAL DATA

Engine:	18 hp Vanguard V-Twin with auto idle
Number of cylinders	2
Engine Oil	10W-30 @ < 40 deg F or 30W @ > 40 deg F
Oil Capacity	56 oz. w/ filter
Fuel Capacity	9 qt.
Fuel Consumption	0.9 gph
Weight:	295 lbs. (HV1810) 300 lbs. (HV1810XL)
Hydraulic System:	Open Center
Pressure Settings	1750, 2000, 2500 psi
Back Pressure	<100 psi @ 10 GPM
Reservoir	6 U.S. gallons—shipping cap and vented fill cap provided
Pump Type	Positive Displacement Gear
Flow Settings	0-10 GPM
Cooling Capacity	16,000 BTU/hr.
Couplings	1/2" HTMA Flush Face
Filter	10 micron
Suction Screen	10 mesh
Filler/Breather	100 mesh
Bi-Directional Valve	Open center 4-way, 3-pos detented valve
Electrical:	
Charging System	12-14V/16 AMP regulated to battery
Battery Type	12V/15 Plate 400 CCA
Fuse Automotive	Ignition 5 AMP
Blade Type	Fan 25 AMP
Tires (HV1810):	
Size	4.80 x 8
Inflation	30 psi
Axle	5/8" diameter

### 2.2 HV1810XL OPTIONS

The HV1810XL model is equipped with the following options:

1. **Engine Hour Meter**—Allows for timely scheduled maintenance of equipment.
2. **Hydraulic Pressure Gauge**—Monitors operating pressures.
3. **Volt Meter**—Indicates battery charge is being maintained.
4. **Wide Tires**—Provide increased stability on rough terrain.

### 2.3 RECOMMENDED HYDRAULIC OIL

Many types of compatible hydraulic oil are available through your local dealer/distributor. As an original equipment manufacturer, RGC uses a Grade ISO VG 32 hydraulic turbine oil.

Extreme weather conditions or operating environments may require using a different viscosity oil or fluid type than what is provided. If you have any question concerning the type of oil suitable for HV1810STD / HV1810XL operation, please consult your local supplier or Reimann & Georger Corporation for details.



## 3 OPERATION

### 3.1 BEFORE OPERATING THE HYDRAPAK



#### **WARNING:**

**ONLY TRAINED PERSONNEL SHALL OPERATE THIS EQUIPMENT. A TRAINED PERSON IS ONE WHO HAS READ AND THOROUGHLY UNDERSTANDS THIS INSTRUCTION MANUAL AND RELATED EQUIPMENT MANUALS AND, THROUGH TRAINING AND EXPERIENCE, HAS SHOWN KNOWLEDGE REGARDING THE SAFE OPERATIONAL PROCEDURES.**



#### **WARNING:**

**FOLLOW THE PRE-OPERATIVE CHECKLIST IN THE FRONT OF THIS MANUAL BEFORE OPERATING.**



#### **CAUTION:**

**USE THE HYDRAPAK WITH OPEN CENTER TOOLS ONLY.**

1. Thoroughly read the engine and associated hydraulic equipment instruction manuals for complete safety, operating and maintenance information before operating.
2. Obey all the safety labels provided on your hydraulic tool and HydraPak. These labels warn you of potential hazards that can cause death or serious injury. If a label comes off or becomes hard to read, contact Reimann & Georger Corporation for replacement information.
3. Construction area is to be kept clear of unauthorized personnel. Place barricades or secure the area in such a manner that no personnel can be injured.
4. Position the HydraPak to minimize the amount of construction debris and dust it receives.

#### **3.1.1 Checking the Engine**

1. Check engine oil level. Refer to Section 2.1 for the type and amount of oil to add.
2. Check the engine cylinder fins, air cleaner, and air intake screen for dirt or obstructions. Clean as required.
3. Fill the fuel tank with an approved fuel container in a well ventilated area. Make sure the gas caps on the HydraPak and fuel container are properly tightened. Move fuel container at least ten feet from HydraPak before starting the engine.
4. For high altitude operation, a carburetor jet kit is required. Consult your local supplier or Reimann & Georger Corporation for details.

#### **3.1.2 Checking the Hydraulic System**

1. Check hydraulic reservoir as follows.
  - a. Replace the shipping cap with the chrome filler/breather cap provided.
  - b. Fluid level should be one inch from the top of tank.

2. Before making any hydraulic connections, inspect all hydraulic lines, fittings and hoses for leaks and risks of rupture as follows:
  - a. Inspect each hydraulic line, fitting, and hose for breaks, cracks, worn spots, bulges, chemical attack, kinks or any other damage. Never try to stop any detected leak with any body parts. Do not put your face close to suspected leaks. Hold a piece of cardboard close to suspected leaks and then inspect the cardboard for signs of hydraulic oil.
  - b. Replace a damaged line, fitting or hose immediately. Never repair the part.



**WARNING:**

**LIQUID UNDER HIGH PRESSURE CAN PIERCE THE SKIN, CAUSING DEATH OR SERIOUS INJURY. IN CASE OF INJURY, GET IMMEDIATE MEDICAL ATTENTION.**

3. The HydraPak uses flush-face quick-release couplings that are durable and easy to clean. Wipe the mating surfaces of the couplings with a clean rag prior to making connection. They are always fitted such that the male coupling gives oil and the female coupling receives oil.
  - a. Connect the return (tank) line from the HydraPak return port to the return port of the hydraulic tool.
  - b. Then connect the pressure line from the hydraulic tool pressure port to the upper (pressure) port on the HydraPak.
  - c. When making connections, do not over stretch the hoses or bend them at a sharp angle.



**WARNING:**

**ENSURE HYDRAULIC HOSES ARE PROPERLY CONNECTED AND IN GOOD CONDITION.**

### **3.2 STARTING AND OPERATING THE HYDRAPAK**

1. Turn the pressure relief lever to the setting that is closest to, but does not exceed, the hydraulic tool's specification.
2. Insure the flow control lever is in the OFF position before starting.
3. Move the engine choke control to start or choke position.
4. Open fuel shut-off valve. Put the throttle to middle position when starting the engine.
5. Insure the auto idle override switch is in the down or "off" position.



**CAUTION:**

**DO NOT OPERATE THE HYDRAPAK WITH THE BATTERY DISCONNECTED.**

6. Start the engine by turning the ignition key clockwise to the START position. Repeat if necessary using short starting cycles (15 sec./min.). If using the pull start, the ignition key must be turned clockwise to the first or "run" position.
7. After starting the engine, open the choke slowly towards the "run" position until engine runs smoothly. Opening the choke fully requires an engine warm-up period of several seconds to several minutes, depending on the temperature.

8. Use the flow control lever to select the GPM setting in accordance with your hydraulic tool instruction manual. Do not exceed the recommended flow and pressure for the hydraulic tool in use.



**WARNING:**

**WHEN OPERATING THE HYDRAPAK, OBSERVE ALL SAFETY PRECAUTIONS DESCRIBED IN THE HYDRAPAK, ENGINE AND HYDRAULIC TOOL INSTRUCTION MANUALS. FAILURE TO COMPLY COULD RESULT IN DEATH, SERIOUS INJURY AND/OR EQUIPMENT DAMAGE.**

9. Do NOT attempt to make any equipment adjustments during operation.

### **3.3 STOPPING THE HYDRAPAK**

At the end of operation, secure the equipment to prevent unauthorized use. Never assume you will find the equipment in the same condition that you left it. Proceed as follows:

1. Let the HydraPak run at idle for about five (5) minutes to cool hydraulic oil and components, or for ten (10) minutes under severe operating conditions.
2. Turn the flow lever to the OFF position.
3. Turn the key counter-clockwise to OFF. When the ignition key is in the OFF position, no electrical power is available to operate the fan or any accessories.



**CAUTION:**

**INSURE THE IGNITION KEY IS TURNED OFF TO PREVENT POWER DRAINAGE FROM THE BATTERY.**

4. Turn the fuel valve on engine OFF.



**CAUTION:**

**INSURE THE FUEL VALVE IS TURNED OFF BEFORE TRANSPORTING THE HYDRAPAK.**

## 4 INSPECTION AND MAINTENANCE

### 4.1 GENERAL MAINTENANCE RULES

1. Proper maintenance of the HydraPak and related hydraulic equipment consists of adhering to all the guidelines given in this chapter and in the Pre-Operative Checklist in the front of this manual. Proper maintenance is required to maintain the system in good condition, which is defined as each part being free of damage or functional defects.
2. Review and follow all the safety rules given in Chapter 1 before attempting any maintenance.
3. Only authorized personnel should be allowed in the maintenance area. Authorized personnel are the trained people as defined below and their supervision.
4. Repairs must be made only by trained personnel. A trained person is one who has read and thoroughly understands this instruction manual and related equipment manuals and, through training and experience, has shown knowledge regarding the safe operational procedures.
5. All authorized maintenance personnel must wear the appropriate personal protective equipment as defined by their employer.



#### **WARNING:**

**SHUT DOWN THE HYDRAPAK BEFORE DOING ANY MAINTENANCE OR REPAIRS. PREVENT ACCIDENTAL STARTUP BY REMOVING THE SPARK PLUG WIRE AND DISCONNECTING THE NEGATIVE WIRE FROM THE BATTERY TERMINAL.**



#### **WARNING:**

**DO NOT ADJUST OR REMOVE HYDRAULIC COMPONENTS, LINES, OR FITTINGS WHILE THE HYDRAPAK IS RUNNING OR WHENEVER THE HYDRAULIC FLUID IS HOT.**



#### **WARNING:**

**LIQUID UNDER HIGH PRESSURE CAN PIERCE THE SKIN, CAUSING DEATH OR SERIOUS INJURY. IN CASE OF INJURY, GET IMMEDIATE MEDICAL ATTENTION.**

### 4.2 HYDRAULIC SYSTEM INSPECTION AND MAINTENANCE

1. Check to see that the hydraulic fluid is clean, and change oil and filter at recommended intervals to extend the life of the HydraPak. Refer to the maintenance summary in Section 4.5.
2. Clean debris from heat exchanger daily.
3. Before making any hydraulic connections, inspect all hydraulic lines, fittings and hoses for leaks and risks of rupture as follows:
  - a. Inspect each hydraulic line, fitting, and hose for breaks, cracks, worn spots, bulges, chemical attack, kinks or any other damage. Never try to stop any detected leak with any body parts. Do not put your face close to suspected leaks. Hold a piece of cardboard close to suspected leaks and then inspect the cardboard for signs of hydraulic oil.
  - b. Replace a damaged line, fitting or hose immediately. Never repair the part.
4. The HydraPak uses flush-face quick-release couplings that are durable and easy to clean. Wipe the mating surfaces of the couplings with a clean rag prior to making connection. They are always fitted such that the male coupling gives oil and the female coupling receives oil.

### **4.3 ELECTRICAL INSPECTION AND MAINTENANCE**

The electrical system requires the following visual inspections before each use of the HydraPak:

1. Fuses must be secured in their holders.
2. All terminal connections must be intact.
3. Insure that battery terminal bolts/nuts are tight.
4. Battery fluid level should be full to within 1/8 inch from bottom of vent well neck.
5. If the battery charge is insufficient to start the engine, it is also insufficient to run the fan or any other accessories. Recharge the battery at once with a 12-volt charger at a rate of 5-30 amp/hour. Rapid charging reduces the life expectancy of any battery. If an overnight charge is possible, proceed with the recommended rate.

### **4.4 ENGINE INSPECTION AND MAINTENANCE**

1. The following rules must be observed when doing engine maintenance:
  - a. Do not check for a spark with the spark plug removed. Use an approved tester.
  - b. Do not crank the engine with the spark plug removed.
  - c. Do not operate the engine without a muffler.
  - d. Do not the start engine with the air cleaner or air cleaner cover removed.
2. Check fuel lines and fittings frequently for cracks or leaks. Replace if necessary.
3. Clean the air cleaner daily. Do not use petroleum solvents (such as kerosene) or pressurized air for this purpose. Replace if very dirty or damaged.
4. Check oil level daily. If oil level is between ADD and FULL mark on dipstick, but a low oil pressure engine shutdown occurs, do not try to use the HydraPak before contacting an authorized service representative. If oil level is below the ADD mark on dipstick, add oil to bring level to the FULL mark before starting the engine.

#### 4.5 MAINTENANCE SCHEDULE

The following table summarizes the type and frequency of maintenance required. Follow the manufacturer's instructions for proper lubrication and detailed maintenance. For repairs, contact the nearest authorized service center.

TYPE OF MAINTENANCE	SERVICE FREQUENCY
Check and clean obstruction from air intake at recoil starter screen	Daily
Check and clean obstruction from heat exchanger*	Daily
Check fuel level in gas tank—add if required	Daily
Check engine oil level—add if required	Daily
Check that reservoir oil level is within one inch below filler cap—add if required	Daily
Check that hydraulic oil is clean	Daily
Wash air filter pre-cleaner	25 hrs.
Change engine oil after first 8 hrs. **	50 hrs.
Check battery electrolyte—add if necessary	50 hrs.
Check air cleaner filter—replace if necessary	100 hrs.
Check and clean obstructions from cooling fins and external surfaces	100 hrs.
Replace engine oil filter	100 hrs.
Check, clean, and replace spark plug	100 hrs.
Have cylinder head removed and cleaned (leaded fuel)	100 hrs.
Have cylinder head removed and cleaned (unleaded fuel)	200 hrs.
Replace reservoir filter and oil after first 50 hrs. ***	250 hrs.
Clean suction screen in reservoir	250 hrs.
Check coupling spider	250 hrs.
Grease wheel bearings	500 hrs.
Check ignition timing	500 hrs.
Check valves and tappet clearance	500 hrs.
Check fuel filter in line	500 hrs.
Lightly oil throttle cable	500 hrs.

\* The hydraulic heat exchanger must always be kept clean and free of obstructions. Check it daily before operating and frequently during use. If debris builds up on the screen during operation, remove debris as soon as it is safely possible.



#### **CAUTION:**

**AN OBSTRUCTED HEAT EXCHANGER WILL CAUSE THE HYDRAULIC SYSTEM AND ENGINE OIL TO OVERHEAT AND FAIL PREMATURELY.**

\*\* Change every 25 hours if engine is operated under heavy load or in high ambient temperatures.

\*\*\* Change more often under heavy duty, high temperature, or high altitude applications. When draining the oil, clean filler/breather cap and replace if damaged.

## 5 TROUBLESHOOTING

The following chart is intended to assist with troubleshooting the HV1810 / HV1810XL HydraPaks. While not all inclusive, the chart outlines the most common causes of a problem and the recommended course of action.

The troubleshooting guide for the associated hydraulic tool is in the manual specifically for this equipment.



**CAUTION:**

**IF THE PROBLEM WITH THE ENGINE IS NOT CERTAIN, ALWAYS FOLLOW THE MANUFACTURER’S WARRANTY POLICY BEFORE ANY OTHER REPAIR OR MAINTENANCE IS ATTEMPTED.**

SYMPTOM	CAUSE AND CORRECTIVE ACTION
<p>HydraPak won’t operate hydraulic tool—engine operating normally.</p>	<p>Low fluid level in reservoir—fill to required level.</p> <p>No hydraulic oil pressure caused by:</p> <ul style="list-style-type: none"> <li>a. Flow lever off—if no flow is selected, there can be no pressure.</li> <li>b. Pressure relief lever set too low—check hydraulic tool requirement and adjust accordingly</li> <li>c. Air in fluid—inspect for oil leaks and repair to correct.</li> </ul> <p>No hydraulic oil flow caused by:</p> <ul style="list-style-type: none"> <li>a. Flow lever off—adjust flow control.</li> <li>b. Hose disconnected—check hose connections.</li> <li>c. Coupling key sheared—inspect and replace.</li> <li>d. Damaged pump—inspect and replace.</li> </ul> <p>Flow restriction caused by:</p> <ul style="list-style-type: none"> <li>a. Kinked or damaged hose</li> <li>b. Pinched or damage steel line</li> <li>c. Poor connection in either a hose or steel line.</li> </ul> <p>Coupling between engine and pump damaged—replace the following items as required:</p> <ul style="list-style-type: none"> <li>a. Coupling spider worn out</li> <li>b. Pump or engine key sheared.</li> </ul> <p>Pump or motor defective—contact the nearest authorized service center.</p>
<p>HydraPak is operating hydraulic tool slowly or erratically—engine operating normally.</p>	<p>Hydraulic tool is being overloaded when working on the construction medium—check hydraulic tool specifications and reduce load on tool as required.</p> <p>Low fluid level in reservoir—fill to required level.</p>

<p>HydraPak is operating hydraulic tool slowly or erratically—engine operating normally (continued).</p>	<p>One or more of the following flow restrictions:</p> <ol style="list-style-type: none"> <li>a. Hose kinked or damaged</li> <li>b. System filter clogged—fluid going through bypass.</li> <li>c. Suction filter clogged—fluid going through bypass.</li> <li>d. Steel line pinched or damaged.</li> <li>e. Heat exchanger clogged.</li> </ol> <p>Erratic pressure caused by:</p> <ol style="list-style-type: none"> <li>a. Contamination in fluid—drain fluid, then inspect and replace filters and fluid.</li> <li>b. Air in fluid—inspect for oil leaks and repair to correct.</li> </ol> <p>Oil viscosity too heavy for cold climate—contact your local supplier or Reimann &amp; Georger Corporation for information.</p> <p>Pump or motor damaged or worn—contact your nearest authorized service center.</p> <p>System relief valve malfunctioning:</p> <ol style="list-style-type: none"> <li>a. Set too low for application.</li> <li>b. Stuck partially open</li> <li>c. Has broken spring.</li> </ol> <p>Extension hoses too long:</p> <ol style="list-style-type: none"> <li>a. Hoses over 50 feet long add sufficient friction to the hydraulic system to slow down the hydraulic tool slightly.</li> <li>b. Where possible, use as few quick disconnects as possible.</li> <li>c. An increase in system pressure may be required to compensate for long hose runs. Consult your local supplier or Reimann &amp; Georger Corporation for information.</li> </ol> <p>Hydraulic oil flow set too low—increase flow using the 0-10 gpm lever.</p> <p>Hydraulic pressure relief set too low—readjust using the 1750/2000/2500-psi lever.</p>
<p>Hydraulic tool is overspeeding</p>	<p>Flow is set too high—make lower selection on 0-10 gpm lever.</p>
<p>System overheats—engine operating normally.</p>	<p>Low fluid level in reservoir—fill to required level.</p> <p>Air in fluid—inspect for oil leaks and repair to correct.</p> <p>Severe operating conditions caused by:</p> <ol style="list-style-type: none"> <li>a. Extremely high ambient temperature-- use a higher viscosity hydraulic oil. Consult your local supplier or Reimann &amp; Georger Corporation for details.</li> <li>b. Extended duty cycle—operate HydraPak intermittently to provide cooling periods</li> </ol>

--	--

<p>System overheats—engine operating normally. (continued)</p>	<p>Pressure relief set too high or too low—make the selection that is closest to, but does not exceed, the hydraulic tool specification:</p> <ol style="list-style-type: none"> <li>a. Setting the relief valve too high forces tool to work at a higher than recommended operating pressure.</li> <li>b. Setting the relief valve too low causes unnecessary bypassing of oil</li> </ol> <p>Heat exchanger not functioning efficiently because:</p> <ol style="list-style-type: none"> <li>a. Air intake or internal parts of heat exchanger clogged/dirty—clear debris as required.</li> <li>b. Fan is not running—see detailed troubleshooting guide below.</li> </ol> <p>Fan is not running because:</p> <ol style="list-style-type: none"> <li>a. Battery was disconnected during a pull start—turn ignition switch to ON position to start fan.</li> <li>b. Fan connection unplugged—check and secure all fan plug connections at fan motor, fan relay, and at any fan override switch on control panel.</li> <li>c. Blown fuse on fan circuit or ignition—replace with specified fuse.</li> <li>d. Defective relay—replace.</li> <li>e. No battery in HydraPak or battery is dead—fan requires a charged 12 volt battery to operate.</li> </ol>
<p>Oil is foaming.</p>	<p>Low fluid level in reservoir—fill to required level.</p> <p>Water in oil.</p> <p>Pump shaft seal worn out causing air to be drawn into pump.</p> <p>Air leak in suction line.</p> <p>Improper type of hydraulic oil--as an original equipment manufacturer, RGC uses a Grade ISO VG 32 hydraulic oil. If you have any questions concerning the type of oil you should use for your HydraPak, consult your local supplier or RGC for details.</p>
<p>Pump leaks.</p>	<p>Plugged reservoir filler/breather.</p> <p>Shipping cap installed—use chrome filler/breather cap supplied.</p> <p>Shaft seal worn on pump.</p> <p>Cracked inlet/outlet fitting.</p>
<p>One or more meters are malfunctioning on HV1810XL model.</p>	<p>Low battery level—recharge battery.</p> <p>Loose or broken connection—repair or replace as required.</p> <p>Electrical problem with meter— contact your local supplier or Reimann &amp; Georger Corporation for information.</p>

Engine does not start	<p>Low oil pressure wire is not disconnected during a pull start—disconnect the wire during a pull start and then reconnect after the engine starts.</p> <p>Flow control lever is not OFF—turn to OFF position.</p>
Engine starts, then stalls almost immediately.	Flow control lever is not OFF—turn to OFF position.
Engine running roughly.	Engine out of adjustment—tune engine after consulting engine manufacturer.
Engine stalls when load is applied.	Defective actuator on electronic governor is failing to move throttle lever—replace actuator as described in the engine manual.
Engine fails to return to idle after a load is removed.	<p>Defective actuator on electronic governor is failing to move throttle lever—replace actuator as described in the engine manual.</p> <p>Auto idle override switch has been left in “bypass”—push switch down to put engine in auto idle mode.</p>
Engine races uncontrollably at full throttle.	Defective control module on electronic governor is triggering actuator to move throttle to wide open position—replace module as described in the engine manual.
Engine frozen.	No oil in crankcase—service at engine manufacturer service center or replace engine with equivalent.
Folding handle is binding.	<p>Hinges are misaligned—realign to match frame width for good slip fit.</p> <p>Handle is being pulled without “D” spring pins inserted—insert to move HydraPak</p> <p>Handle folded improperly—pull out and down.</p> <p>Lack of lubrication—place a few drops of oil at pivot points and on sliding hinges inside frame tubes.</p>
Problem with split frame reassembly	Misalignment of top / bottom halves—align and assemble using grease to lube four frame telescoping sleeves, then secure with appropriate hardware.

## 6 PARTS LIST

The following parts list applies to the HV1810STD, HV1810XL BI-Directional HydraPacs only. Each item number on this parts list can be matched with the item number shown on the Figure 6-1 assembly drawing.

Item Number	Part Number	Quantity	Description
1	2546004	1	MAIN FRAME
2	5507447	1	ENGINE 18HP VANGUARD
	5507742	1	MUFFLER
3	2510872	1	RESERVOIR
4	6000921	1	FILLER BREATHER CAP
5	6000908	1	SUCTION STRAINER ASSY
6	5800138	4	CLEVIS PIN ROUNDED SNAP
7	2546006	1	FRAME HANDLE
8	6001883	1	COUPLING 1/2" MALE NPT
9	6001884	1	COUPLING 1/2" FEMALE NPT
10	5411512	1	WIRE HARNESS W / AUTO IDLE
11	2514302	1	HEAT EXCHANGER ASSY
12	6000855	1	HEAT EXCHANGER CORE
13	5401513	1	FAN 10"
14	5800387	2	COTTER HAIR PIN
15	6901510	1	HYDRAULIC PUMP
16	5400861	1	BATTERY
	5401564	1	BATTERY STRAP
17	6901501	1	HYDRAULIC PUMP BRACKET
17	6901502	1	PUMP ACCESS COVER
18	5493623	1	STARTER WIRE
19	5701570	1	VOLT METER (XL)
20	5701972	1	PRESSURE GAGE (XL)
21	5701571	1	HOUR METER
22	2501545	1	CONTROL PANEL
22	2501540	1	CONTROL PANEL (XL)
23	7601523	2	TIRE AND RIM ASSY—WIDE (XL)
23	7600871	2	TIRE AND RIM ASSY—STANDARD
24	6004723	1	HYDRAULIC FILTER ELEMENT
25	6000904	1	HYDRAULIC FILTER ASSY
26	6004722	1	HYDRAULIC FILTER HEAD
27	2501524	1	AXLE—WIDE TIRE (XL)
27	2504743	1	AXLE—STANDARD TIRE
28	5401511	1	FAN RELAY
29	5401562	1	TOGGLE SWITCH
30	6011553	1	PRESSURE SENSOR AUTO IDLE
31	6015301	1	FLOW CONTROL VALVE
32	6015302	1	FLOW CONTROL HANDLE ASSY 10 POSITION
33	6061132	2	HANDLE ONLY FOR 3 POSITION & 10 POSITION ASSY'S
34	6015304	1	PRESSURE CONTROL HANDLE ASSY 3 POSITION
35	6015303	1	PRESSURE CONTROL VALVE

36	6001530	1	MANIFOLD
37	6015308	3	RELIEF VALVE
38	6015306	1	PILOT LOGIC ELEMENT
39	6015305	1	CHECK VALVE
40	6700904	1	COUPLING HALF 3/4" - PUMP
41	6700907	1	COUPLING INSERT
42	6700906	1	COUPLING HALF 1" - ENGINE
44	5007557	3	SPACER FOR BRAND VALVE
45	5600958	2	NIPPLE HEX 1/2 NPTM
46	6004795	1	VALVE- HYDRAPAK WINCH CONTROL
47	6004802	1	DETENT KIT DOUBLE BRAND
48	5806214	3	HHCS 1/4-20 X 2-3/4 CZP
49	5806366	3	NUT HEX TOPLOCK 1/4-20 CZP
50	5806202	4	HHCS 1/4-20 X 1/2 CZP
51		2	FITTING AEROQUIP 2062-8-8S
52		1	FITTING AEROQUIP 2021-12-8S
53		1	FITTING AEROQUIP 2024-12-8S
54		1	1/2 TUBE/W FITTINGS

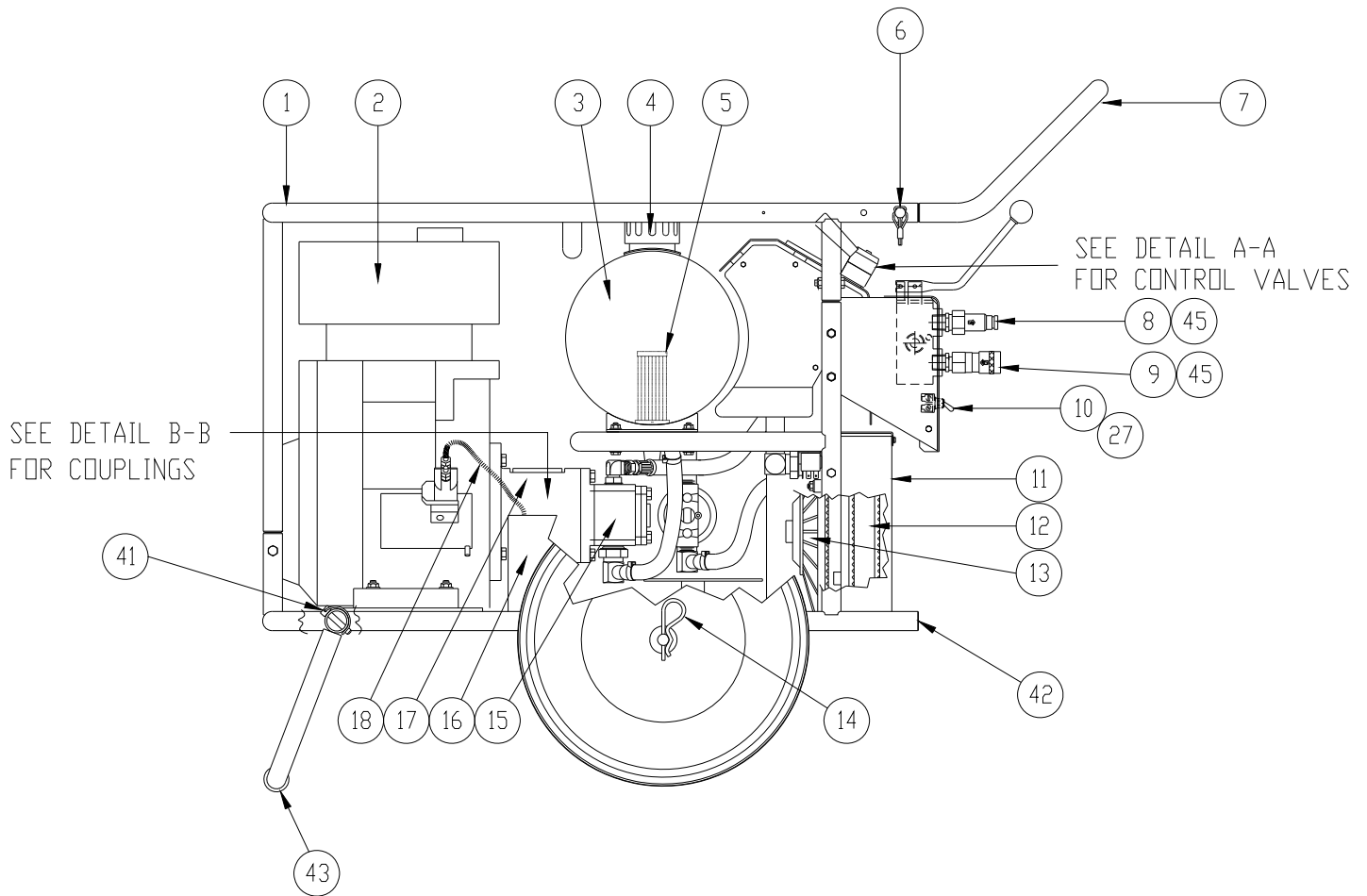

**Figure 6-1.**  
**HV1810STD, HV1810XL Assembly Drawing**

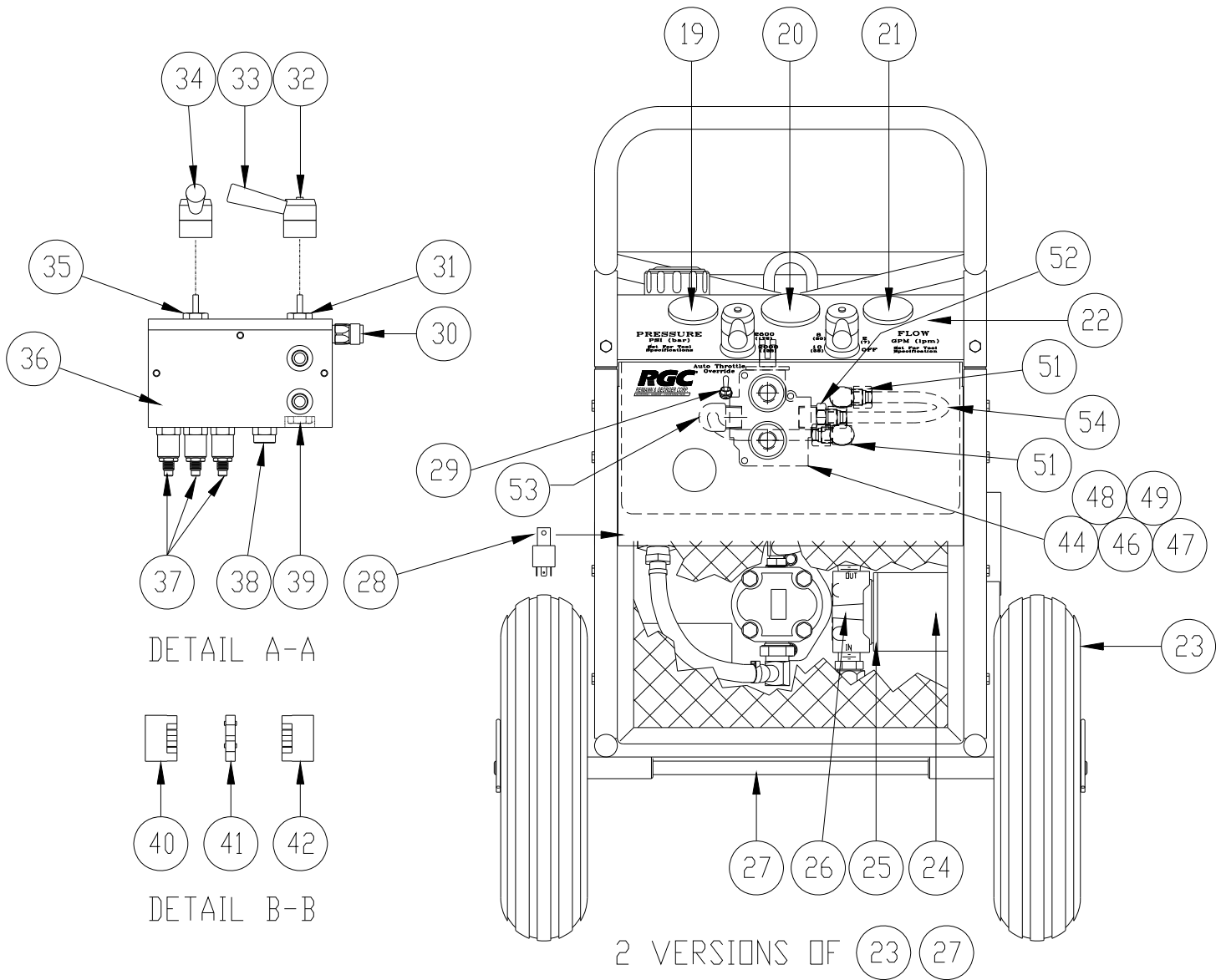

**Figure 6-2.**  
**HV1810STD, HV1810XL Assembly Drawing**

## **LIMITED PRODUCT WARRANTY**

**Reimann & Georger Corporation  
Hoisting and Construction Products**

### **A. LIMITED WARRANTY**

Reimann & Georger Corporation (the “Manufacturer”) warrants to the original purchaser (the “Buyer”) that all Reimann & Georger Hoisting and Construction products shall be free of defects in material and workmanship for a period of one (1) year from date of original purchase.

### **B. MANUFACTURER’S OBLIGATIONS**

The Manufacturer’s sole obligation under this Limited Warranty is the repair or, at the Manufacturer’s discretion, the replacement of parts found to be defective. Parts and equipment must have authorization from the Manufacturer prior to return to the Manufacturer or repair by an authorized service person. Costs of transportation and other expenses connected with replacing or repairing parts are not covered under this Limited Warranty.

### **C. PARTS MANUFACTURED BY OTHERS**

This Limited Warranty does not cover any parts manufactured by others. Such parts are subject to the warranty, if any, of their respective manufacturers, and are to be repaired only by a respective authorized service person for such parts. The Manufacturer shall have no obligation to undertake repairs of parts manufactured by others.

### **D. NO SPECIAL, INCIDENTAL, OR CONSEQUENTIAL DAMAGES**

**IN NO EVENT SHALL THE MANUFACTURER BE LIABLE TO THE BUYER OR ANY OTHER PERSON FOR ANY INDIRECT, SPECIAL, INCIDENTAL OR CONSEQUENTIAL LOSSES OR DAMAGES CONNECTED WITH THE USE OF THE PRODUCT UNDER THIS LIMITED WARRANTY. SUCH DAMAGES FOR WHICH THE MANUFACTURER SHALL NOT BE RESPONSIBLE INCLUDE, BUT ARE NOT LIMITED TO, LOST TIME AND CONVENIENCE, LOSS OF USE OF THE PRODUCT, THE COST OF A PRODUCT RENTAL, COSTS OF GASOLINE, TELEPHONE, TRAVEL, OR LODGING, THE LOSS OF PERSONAL OR COMMERCIAL PROPERTY, AND THE LOSS OF REVENUE.**

### **E. NO LIABILITY IN EXCESS OF PURCHASE PRICE**

**IN NO EVENT SHALL THE MANUFACTURER’S OBLIGATIONS UNDER THIS LIMITED WARRANTY EXCEED THE PURCHASE PRICE OF THE PRODUCT.**

### **F. NO EXTENSION OF STATUTE OF LIMITATIONS**

**ANY REPAIRS PERFORMED UNDER THIS WARRANTY SHALL NOT IN ANY WAY EXTEND THE STATUTES OF LIMITATIONS FOR CLAIMS UNDER THIS LIMITED WARRANTY.**

### **G. WAIVER OF OTHER WARRANTIES**

**THE EXPRESS WARRANTIES SET FORTH IN THIS LIMITED WARRANTY ARE IN LIEU OF AND EXCLUDE ANY AND ALL OTHER WARRANTIES, EXPRESS OR IMPLIED, INCLUDING, BUT NOT LIMITED TO, THE IMPLIED WARRANTIES OR MERCHANTABILITY AND FITNESS FOR A PARTICULAR PURPOSE.**

### **H. PROCEDURE FOR WARRANTY PERFORMANCE**

If the product fails to perform to the Manufacturer’s specifications, the Buyer must provide the Manufacturer with the applicable model and serial numbers, the date of purchase, and the nature of the problem.

**I. ADDITIONAL EXCLUSIONS FROM THIS LIMITED WARRANTY. THIS LIMITED WARRANTY DOES NOT COVER ANY OF THE FOLLOWING:**

1. Equipment which has been abused, damaged, used beyond rated capacity, or repaired by persons other than authorized service personnel.
2. Damage caused by acts of God which include, but are not limited to, hailstorms, windstorms, tornadoes, sandstorms, lightning, floods, and earthquakes.
3. Damage under conditions caused by fire or accident, by abuse or by negligence of the user or any other person other than the Manufacturer, by improper installation, by misuse, by incorrect operation, by "normal wear and tear", by improper adjustment or alteration, by alterations not completed by authorized service personnel, or by failure of product parts from such alterations.
4. Costs of repairing damage caused by poor or improper maintenance, costs of normally scheduled maintenance, or the cost of replacing any parts unless done as the result of an authorized repair covered by the one (1) year Limited Warranty.
5. Costs of modifying the product in any way once delivered to the Buyer, even if such modifications were added as a production change on other products made after the Buyer's product was built.

**J. NO AUTHORITY TO ALTER THIS LIMITED WARRANTY**

No agent, representative, or distributor of the Manufacturer has any authority to alter the terms of this Limited Warranty in any way.