



# TS14 TRENCHSAW INSTRUCTIONS

REIMANN & GEORGER CORPORATION  
CONSTRUCTION PRODUCTS  
P/N 6122075

BUFFALO, NY  
09/15/09

## TABLE OF CONTENTS

CHAPTER	TITLE	PAGE
<b>1</b>	<b>SAFETY .....</b>	<b>1</b>
1.1	Introduction .....	1
1.2	Safety Definitions .....	1
1.3	Power Source and Saw Safety Labels .....	1
1.4	TS14 Trenchsaw Safety Rules .....	1
<b>2</b>	<b>SPECIFICATIONS .....</b>	<b>3</b>
2.1	Introduction .....	3
2.2	Technical Data .....	3
2.3	Blade Performance Requirements .....	3
2.4	Hydraulic Power Source Requirements .....	4
2.5	Recommended Hydraulic Oil .....	4
2.6	Nameplate and Serial Number Tag .....	4
<b>3</b>	<b>OPERATION .....</b>	<b>5</b>
3.1	Component Pre-Start Checks .....	5
3.1.1	Hydraulic System .....	5
3.1.2	Flanges and Blade .....	5
3.2	Starting the System .....	5
3.3	Cutting Procedure .....	6
3.4	Shutdown and Storage .....	7
<b>4</b>	<b>INSPECTION AND MAINTENANCE .....</b>	<b>8</b>
4.1	General Maintenance Rules .....	8
4.2	Daily Inspection and Maintenance .....	8
4.3	Blade Removal and Installation .....	8
4.3.1	Blade Removal .....	8
4.3.2	Blade Installation .....	8
4.4	Arbor Flange Removal and Installation .....	9
4.4.1	Arbor Flange Removal .....	9
4.4.2	Arbor Flange Installation .....	9
<b>5</b>	<b>TROUBLESHOOTING .....</b>	<b>10</b>
5.1	Locating the Problem Area .....	10
5.2	Troubleshooting the Saw .....	10
<b>6</b>	<b>PARTS LIST .....</b>	<b>13</b>

## LIST OF FIGURES

FIGURE	DESCRIPTION	PAGE
2-1	Typical TS14 Trenchsaw Product Nameplate .....	4
6-1	TS14 Trenchsaw Assembly .....	14

# 1 SAFETY

## 1.1 INTRODUCTION

Your Reimann & Georger Corporation TS14 Trenchsaw has been engineered to provide sawing performance, long term economics and safety advantages that no other type can match. However, even a well-designed and well-built saw can malfunction or become hazardous in the hands of an inexperienced and/or untrained user. Therefore, read this manual and related equipment manuals thoroughly before operating your saw to provide maximum safety for all operating personnel, and to get the maximum benefit from your equipment.

## 1.2 SAFETY DEFINITIONS

A safety message alerts you to potential hazards that could injure you or others or cause property damage. The safety messages or signal words for product safety signs are **DANGER**, **WARNING**, and **CAUTION**. Each safety message is preceded by a safety alert symbol and is defined as follows:

**DANGER:** Indicates an imminently hazardous situation which, if not avoided, **will** cause death or serious injury. This safety message is limited to the most extreme situations.

**WARNING:** Indicates a potentially hazardous situation which, if not avoided, **could** result in death or serious injury.

**CAUTION:** Indicates a potentially hazardous situation which, if not avoided, **may** result in minor or moderate injury. It may also be used to alert against unsafe practices that may result in property-damage-only accidents.

## 1.3 POWER SOURCE AND SAW SAFETY LABELS

These labels warn you of potential hazards that could cause injury. Read them carefully. If a label comes off or becomes illegible, contact Reimann & Georger Corporation for a free replacement.

## 1.4 TS14 SAW SAFETY RULES

1. Only trained personnel shall operate the saw or perform repairs. A trained person is one who has read and thoroughly understands this instruction manual and related equipment manuals and, through training and experience, has shown knowledge regarding the safe operational procedures.
2. Sawing area must be kept clear of unauthorized personnel at all times. Place barricades or secure the area with signs and a roped boundary to prevent personnel injury.
3. Never use the saw in an explosive atmosphere and/or near combustible material that could be ignited by a spark.
4. Do not use a saw that shows any signs of damage. Do not use the saw if the blade does not stop rotating when the power-activating trigger lever is released.
5. The guard provides protection against contact with moving parts, ejected debris, and during wet cutting operations, thrown water and concrete slurry. Adjust the blade guard for the cut being made. Never run the saw without the blade guard in place.
6. Never allow anyone to stand in front of, or in line with, the blade forward of the guard.
7. Always use blades that meet applicable safety code specifications. Read and comply with blade manufacturer's instructions and safety precautions provided with the blade. Destroy any blade with cracks, chips, gouges, or loose or missing tips.

8. **Always** use safety footwear, safety goggles or face shields, and hearing and head protection devices. Safety shoes **MUST** provide good footing to prevent slipping or falling down. Gloves protect the hands from chips and should be worn. During dry cutting operations, provide also adequate ventilation or approved NIOSH or MSHA respirators in closed areas to avoid breathing dust. During wet cutting operations, use also a snug fitting wet suit.
9. Do not use the saw when you are tired or fatigued.
10. Never operate the saw under the influence of drugs, alcohol, or medication.
11. Always carry the saw in its de-energized state.
12. Keep the saw handles dry, clean, and free of oil or fuel.
13. This saw is not insulated. Do not start cutting without first de-energizing electrical wiring near the cutting site or imbedded in any concrete.
14. Prior to cutting, plan your cuts to prevent pinching of the blade or personnel injury from falling material.
15. Always hold the saw with both hands during operation. Use a firm grip on the handles.
16. Never exceed the maximum flow and pressure rating of the saw, which is 8 gpm at 2500 psi.
17. Do not exceed either the maximum operating speed of 4100 rpm or the blade manufacturer's rated speed.
18. Do **NOT** attempt to adjust the saw during operation.
19. Keep clothing and all parts of the body away from moving parts of this saw when connected to a power source or being used.
20. Any slurry formed during wet cutting operations is very slick. Remove while still wet to prevent yourself or others from slipping while cutting. Slurry that has been allowed to dry is very difficult to remove.
21. Always shut off the hydraulic power and cooling water sources before disconnecting the hoses or servicing the saw. Never remove fittings or components when hydraulic fluid is hot.
22. Always shut off the hydraulic and cooling water sources when not using the equipment.

## 2 SPECIFICATIONS

### 2.1 INTRODUCTION

Your Reimann & Georger Corporation TS14 hydraulic direct drive Trenchsaw is a rugged versatile saw that cuts cleanly, fast, precisely, and straight through concrete, steel, stone, composition material, or hard fiber when equipped with the appropriate abrasive or diamond blade. The slim line design of the saw allows cuts to be made within inches of a wall or an obstruction. The saw is equipped with a water hose connection for wet cutting and 12-inch long hose whips. An arbor wrench is provided for removing and installing blades. As with most hydraulic tools, the hydraulic system requirements detailed in the following sections must be met to support tool performance and longevity of equipment.

The following features are provided:

- 12-inch hose whips
- Blade drive pin
- Trigger actuated water supply

### 2.2 TECHNICAL DATA

The following specifications apply to the TS14 Trenchsaw.

	ENGLISH	METRIC
<b>Tool Physicals</b>		
Weight (w/o blade)	27.4 lbs.	(12.5 kg.)
Length (w/o blade)	18.2 in.	(460 mm)
Length (w/ Blade)	23.3 in.	(590 mm)
Width	16 in.	(406 mm)
Maximum Blade Diameter	14 in.	(356 mm)
Arbor Diameter	1 in.	(25 mm)
<b>Hydraulic Requirements</b>		
Type of System		Open-Center
Flow Rate	5-8 gpm	(20-30 lpm)
Maximum Pressure Range	2000-2500 psi	(136-172 bar)
Maximum Pressure Relief Setting	2500 psi	(172 bar)
Filtration		10 microns (nominal)
Back Pressure (Max)	500 psi	(34 bar)
Hose Length (Max)	100 ft.	(30 m)
Couplings		1/2" HTMA flush face
<b>Water Requirements for Wet Cutting</b>	Use the flow and pressure recommended by the blade manufacturer	
<b>Operation</b>		
Speed @ 5 gpm		2570 rpm
@ 6 gpm		3080 rpm
@ 7 gpm		3590 rpm
@ 8 gpm		4100 rpm
Cutting Depth	5.25 in.	(132 mm)

### 2.3 BLADE PERFORMANCE REQUIREMENTS

Any blade from your supplier must meet the following design criteria. **Using blades on this saw that don't meet these requirements can cause equipment damage and/or personal injury.**

1. Use blades that meet applicable industrial safety code specifications.
2. Use blades that are approved by the blade manufacturer for the material to be cut.

3. Use approved dry cutting type blades in dry cutting operations and approved wet cutting type blades in wet cutting operations.
4. Do not exceed either the maximum operating speed of 4100 rpm or the blade manufacturer's rated speed. Blades must be speed tested to ANSI B7.1 safety code specifications.
5. When using abrasive blades, always use blades with mounting blotters on both sides. Remove the drive screw from arbor flange before mounting an abrasive blade.

## 2.4 HYDRAULIC POWER SOURCE REQUIREMENTS

The hydraulic power source must meet the following design criteria.

1. The flow must not exceed 8 gpm and the pressure relief valve must not exceed 2500 psi @ 8 gpm. **Failure to comply could cause excessive blade rpm and/or overpressurizing the system, resulting in equipment damage and/or personal injury.**



### **WARNING:**

**NEVER EXCEED 8 GPM FLOW. BLADE FAILURE MAY RESULT DUE TO EXCESSIVE SPEED.**

2. The hydraulic power source must meet the hydraulic requirements of Section 2.2.

## 2.5 RECOMMENDED HYDRAULIC OIL

Viscosity	140-225 SUS @ 100°F	(28-45 cSt @ 38°C)
	40 min. SUS @ 210°F	(8 min. cSt @ 99°C)
Flash Point	340°F min.	(170°C min.)
Pour Point	-30°F min.	(-34°C min.)

Many types of compatible hydraulic oil are available through your local dealer/distributor. As an original equipment manufacturer, RGC uses a Grade ISO VG 32 hydraulic turbine oil.

Hydraulic oil types are too numerous to list in this manual. If you have any question concerning the type of oil suitable for Trenchsaw operation, please consult your local supplier or Reimann & Georger Corporation for details.

## 2.6 NAMEPLATE AND SERIAL NUMBER TAG

It is important to identify the saw completely and accurately whenever ordering spare parts or requesting assistance in service. The saw has a product nameplate that states the model and serial numbers. The saw label should appear as the sample nameplate shown in Figure 2-1. Record the model and serial numbers for future reference.

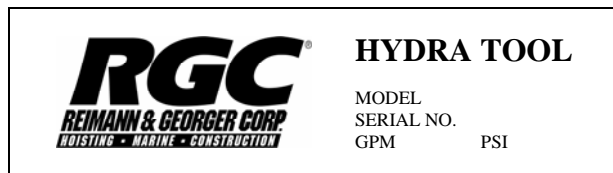

**Figure 2-1.**  
**Typical TS14 Product Nameplate**

**MODEL** \_\_\_\_\_

**SERIAL NUMBER** \_\_\_\_\_

## 3 OPERATION

Follow all the safety procedures in Chapter 1 of this manual and in the manual supplied with your hydraulic power unit. **Failure to do this can cause equipment damage and/or personal injury.** Make sure you are wearing all your safety equipment including approved NIOSH or MSHA respirators during dry cutting or a wet suit during wet cutting.

### 3.1 COMPONENT PRE-START CHECKS

The following components must be checked before you can use the saw safely. Running the saw with an undetected defect in either of these components will quickly cause equipment damage.

1. Hydraulic system
2. Flanges and Blade

#### 3.1.1 Hydraulic System

1. Before making any hydraulic connections, inspect all hoses for leaks and risks of rupture as follows:
  - a. Inspect each hose for breaks, cracks, worn spots, bulges, chemical attack, kinks or any other damage. Never stop any detected leak with your hand or fingers. Do not put your face close to suspected leaks. Hold a piece of cardboard close to suspected leaks and then inspect the cardboard for signs of hydraulic oil.
  - b. Replace a damaged hose immediately. Never repair the hose.
2. Clean fittings before making connections to prevent contamination of hydraulic system. First connect the return (tank) line from the saw return port to the hydraulic power source return port. Then connect the pressure line from the saw pressure port to the hydraulic power source pressure port.
3. Pressure relief valve must not exceed 2500 psi @ 8 gpm. The pressure relief valve must be located in the supply circuit between the power supply and tool to limit excessive hydraulic pressure to the tool.

#### 3.1.2 Flanges and Blade

1. Inspect the flange and arbor flange for gouges, hairline cracks, and wear. Replace these flanges immediately if any of these conditions are present as described in Chapter 4.
2. Be sure flanges are clean and straight so blade will run true on sides.
3. Always use the blade recommended by the blade manufacturer for your application. Use approved dry cutting type blades in dry cutting operations and approved wet cutting type blades in wet cutting operations.
4. Inspect the blade for cracks, chips, gouges, or loose or missing tips. Destroy the blade if any of these conditions are present.
5. Insure a blade is installed to blade manufacturer's specified direction of rotation. Saw rotation is clockwise as viewed from the blade side of the saw.

### 3.2 STARTING THE SYSTEM

1. This saw is not insulated. Do not start cutting without first checking for live electrical wiring near the cutting site, or imbedded in the cutting medium. If power lines are unavoidable, consult power company before starting operation.

2. The following precautions must be observed when lifting the saw:
  - a. Be sure of your footing.
  - b. Keep hands off trigger to avoid accidental operation.
3. Insure the power supply is turned off. Adjust the blade guard to provide the best operator protection from the angle of the cut to be made. To adjust the blade guard, loosen the two knobs and rotate the guard to the desired position. Then retighten the knobs securely.



**WARNING:**

**THE GUARD PROVIDES PROTECTION AGAINST CONTACT WITH MOVING PARTS, EJECTED DEBRIS, AND DURING WET CUTTING OPERATIONS, THROWN WATER AND CONCRETE SLURRY. NEVER RUN THE SAW WITHOUT THE BLADE GUARD IN PLACE.**

4. Always check the hydraulic flow and pressure rating of the hydraulic power unit before using to prevent equipment damage. Do not exceed the maximum hydraulic flow rate and pressure of 8 gpm (30 lpm) and 2500 psi (172 bar). Overspeeding the blade can cause equipment damage and possible personal injury.
5. Check that the pressure and return hoses are connected properly to the saw and hydraulic power source as described in Section 3.1.1.
6. Before starting your power supply, read and fully understand the operating manual provided.
7. Use caution when handling fuel for a gasoline engine driven hydraulic power source. Move the hydraulic power source at least 10 feet from the fueling point before starting the engine. Make sure the gas caps on the hydraulic power source and fuel can are properly tightened.

### **3.3 CUTTING PROCEDURE**

1. Provide rigid support and “hold down” of piece being cut—both sides of the cut, if practical.
2. Grasp the auxiliary handle with your left hand. Use the appropriate part of the handle for making vertical or horizontal cuts.
3. Grasp the trigger with your right hand.
4. Position the saw in the appropriate place to make the desired cut.
5. Disengage the trigger lockout. Then depress (squeeze) the trigger to start the saw. Never exceed either the blade maximum operating speed of 4100 rpm or the blade manufacturer’s rated speed.
6. Feed the rotating blade into the work surface using a straight, steady, constant pressure. Do NOT “bump,” jam or force the blade into the work surface, or twist the blade in the cut. This can cause equipment damage.



**WARNING:**

**ALWAYS START AND FINISH A SAW CUT WITH THE SAME WIDTH OF BLADE. IF BLADE TYPE OR WIDTH IS CHANGED, START A NEW SAW CUT. FAILURE TO DO THIS CAN CAUSE EQUIPMENT DAMAGE AND/OR PERSONAL INJURY.**

### 3.4 SHUTDOWN AND STORAGE

1. To stop the saw, release the trigger.
2. AFTER the blade has stopped rotating, lay the saw on a flat surface.
3. Stop the hydraulic power source following the procedure in the respective instruction manual.
4. Shut off water supply.



#### **CAUTION:**

**ALWAYS SHUT OFF THE COOLING WATER WHEN THE TOOL IS NOT IN USE. LEAVING THE WATER RUNNING UNATTENDED CAN CAUSE EQUIPMENT OR PROPERTY DAMAGE.**

5. Clean concrete slurry and debris off saw. Once concrete slurry is dry, it is very hard to remove and may hamper the operation of moving parts.
6. Disconnect the hoses from the saw.



#### **WARNING:**

**NEVER DISCONNECT ANY HYDRAULICALLY OPERATED PART OF THE SAW OR REMOVE HYDRAULIC COMPONENTS, LINES, OR FITTINGS WHILE THE POWER SOURCE IS RUNNING OR WHENEVER THE HYDRAULIC FLUID IS HOT.**

**LIQUID UNDER HIGH PRESSURE CAN PIERCE THE SKIN, CAUSING SERIOUS INJURY OR DEATH. HOT LIQUID CAN CAUSE SERIOUS PERSONAL BURNS. IF AN INJURY OCCURS, GET IMMEDIATE MEDICAL ATTENTION.**

7. Secure the saw and hydraulic power source to prevent unauthorized use.
8. Store the saw in a clean, dry area away from exposure to high heat and humidity, water, other liquids, or freezing temperatures. Avoid temperatures low enough to cause condensation on the blade when moving it from storage to a higher temperature. Always handle and store blades carefully.
9. Do not stack material on top of the saw that may cause the blade to bend or deform.

## 4 INSPECTION AND MAINTENANCE

### 4.1 GENERAL MAINTENANCE RULES

1. Proper maintenance of the saw and related equipment requires timely adhering to all the guidelines given in this chapter. Proper maintenance is required to maintain the system in good condition and free of defects.
2. Review and follow all the safety rules given in Chapter 1 before attempting any maintenance.
3. Before starting any maintenance always wear appropriate personal safety equipment.
4. Repairs must be made only by trained personnel. A trained person is one who has read and thoroughly understands this instruction manual and related equipment manuals and, through training and experience, has shown knowledge regarding the safe operational procedures.
5. Disconnect the cooling water and power supplies before starting.



#### **WARNING:**

**FAILURE TO DISCONNECT THE POWER SUPPLY BEFORE STARTING CAN CAUSE EQUIPMENT DAMAGE AND/OR PERSONAL INJURY.**

6. Hydraulic fluid can become contaminated after extended periods of use which can cause restrictions in the system. Check to see that the fluid is clean and change at recommended intervals to extend saw's life. Refer to the respective manual for maintenance information on the hydraulic power source.

### 4.2 DAILY INSPECTION AND MAINTENANCE

1. Inspect the blade mounted on the saw. Remove and destroy blade if any cracks, chips, gouges, or loose or missing segments are present. Failure to do this can cause personal injury.
2. Inspect the hydraulic system hoses and fittings as described in Section 3.1.1. Failure to do this can cause personal injury. Never try to repair a damaged hose. Replace it immediately.
3. Wipe all tool surfaces clean of dirt and foreign material.

### 4.3 BLADE REMOVAL AND INSTALLATION

#### 4.3.1 Blade Removal

1. Loosen and/or remove the #22,24, & 38 screws (5 total) holding the blade guard in place.
2. Loosen and remove the arbor nut using the provided arbor wrench. The arbor nut has left hand threads. Turn the arbor nut clockwise to loosen and remove.
3. Remove the flange and blade from the arbor shaft.

#### 4.3.2 Blade Installation

1. Inspect the arbor flange for gouges, warps, nicks, hairline cracks, wear, dirt, or sprung condition. Replace the arbor flange immediately if any of these conditions are present as described in Section 4.4.
2. Any blade to be installed must comply with all the safety information and specifications listed in Chapter 2. Destroy any damaged blade as described in Section 4.2.

- Abrasive blades must have mounting blotters on both sides and be speed tested per ANSI B7.1 Safety Code specifications. **DESTROY THE BLADE IF IT DOES NOT MEET ANSI B7.1 SPECIFICATIONS.** Make sure the blotters are in good condition between the blade and flanges. The cushion provided by the blotters protects the blade from uneven strain.
- Remove the drive screw from arbor flange when using an abrasive blade. Install the blade on the arbor shaft. Make sure a blade is installed correctly to the rotation of the saw. Saw rotation is clockwise as viewed from the arbor nut side of the saw.



**CAUTION:**

**DO NOT FORCE A BLADE ONTO THE ARBOR FLANGE OR USE A BLADE THAT FITS THE ARBOR TOO LOOSELY. NEVER ALTER THE SIZE OF THE ARBOR HOLE. THE BLADE MUST FIT THE ARBOR FLANGE PROPERLY.**

- Inspect the flange for gouges, warps, nicks, hairline cracks, wear, dirt, or sprung condition. Replace the flange immediately if any of these conditions are present. Install the flange on the arbor shaft.
- For blades that require a drive screw, insure the screw #55 is installed in the flange to prevent blade slippage between the two flanges.
- Thread the arbor nut counter-clockwise on the arbor shaft. Tighten using the provided arbor wrench. Be sure the flanges are tightened securely, but not excessively. Excessive tightening will spring the flanges and change the pressure area.
- Tighten the five blade guard screws to secure the blade guard. **NEVER** operate the saw without the guard in place.

#### **4.4 ARBOR FLANGE REMOVAL AND INSTALLATION**



**CAUTION:**

**DO NOT STRIKE THE ARBOR FLANGE WITH A HAMMER OR OTHER SIMILAR TOOL WHEN PULLING IT OFF OR INSTALLING IT ON THE MOTOR SHAFT. THE ARBOR FLANGE OR MOTOR COULD BE DAMAGED.**

##### **4.4.1 Arbor Flange Removal**

- Remove the blade from the arbor shaft as described in Section 4.3.1.
- Loosen the set screw that secures the arbor flange to the motor shaft.
- Insure bolt on arbor removal tool is threaded out to its outer-most position. Thread arbor removal tool counter-clockwise onto arbor shaft. Screw arbor removal tool bolt clockwise to pull arbor flange off motor shaft.

##### **4.4.2 Arbor Flange Installation**

- Insure the arbor flange fits snugly on the motor shaft. Then remove the arbor flange from the motor shaft.
- Apply Loctite RC609 or equivalent on the motor shaft. Follow the manufacturer's instructions for curing. Install the arbor flange on the motor shaft.
- Tighten the set screw in the arbor flange securely.
- Re-install the blade on the arbor shaft as described in Section 4.3.2.

## 5 TROUBLESHOOTING

### 5.1 LOCATING THE PROBLEM AREA

If the saw does not operate, the problem is either in the saw, the hoses, or the power supply. Locate the problem area as follows:

1. Stop the power supply.
2. Disconnect the existing saw from the hoses and power supply.
3. Connect a known working saw to the hoses and power supply. Refer to this manual for the proper hook-up procedure.
  - a. If the known working saw operates, the problem is in the disconnected saw. See the troubleshooting chart in Section 5.2.
  - b. If the known working saw does not operate, the problem is probably in the hose or power supply. Proceed to Step 4.
4. Stop the power supply.
5. Disconnect the existing hoses from the known working saw and power supply.
6. Connect a different set of hoses to the known working saw and power supply.
  - a. If the known working saw operates with the different set of hoses, the problem is in the disconnected hoses.
  - b. If the known working saw does not operate, the problem is in the power supply. See the power supply operating manual for troubleshooting.

### 5.2 TROUBLESHOOTING THE SAW

The following chart is intended to assist with troubleshooting the TS14 Trenchsaw. While not all inclusive, the chart outlines the most common causes of a problem and the recommended course of action.

The troubleshooting guide for the associated power supply is in the instruction manual specifically for this unit.

SYMPTOM	CAUSE	CORRECTIVE ACTION
Saw inoperative	Saw connected to improper power supply hydraulic system.	See Chapter 2 for type of hydraulic system required. Verify power supply hydraulic system.
	No hydraulic fluid in system or fluid level low.	Check fluid level. Fill to full mark. Check system for leaks.
	Saw parts loose.	Tighten component hardware.
	Dirt or contaminants in saw parts.	Disassemble saw and clean parts.
	Saw parts worn or damaged.	Disassemble saw and replace worn or damaged parts.

Saw operates erratically	<p>Leak in system.</p> <p>Saw parts sticking or binding.</p> <p>Dirt or contaminants in saw parts.</p>	<p>Tighten fittings. Inspect all hoses for leaks as described in Section 3.1.1. <b>REPLACE A LEAKING HOSE IMMEDIATELY. NEVER TRY TO REPAIR IT.</b></p> <p>Check for dirt or gummy deposits. Clean parts.</p> <p>Check for worn or damaged parts and replace as required.</p> <p>Be sure flanges are clean and straight so blade will run true on sides. See Chapter 4 for proper blade mounting procedure.</p> <p>Disassemble saw and clean parts.</p>
Saw operates slowly.	<p>Insufficient flow.</p> <p>Hydraulic fluid level low.</p> <p>Hydraulic fluid viscosity too heavy.</p> <p>Saw parts loose.</p> <p>Saw parts worn or damaged.</p>	<p>Refer to power source operator's manual for proper adjustment of flow.</p> <p>Check fluid level. Fill to full mark. Check system for leaks.</p> <p>Use fluid viscosity recommended. See Section 2.5.</p> <p>Tighten component hardware.</p> <p>Disassemble saw and replace worn or damaged parts.</p>
Saw feels hot.	<p>Power source heat exchanger malfunctioning</p> <p>Hydraulic fluid level low.</p> <p>Hydraulic fluid dirty.</p> <p>Excessive flow</p>	<p>Refer to power source operator's manual.</p> <p>Check fluid level. Fill to full mark. Check system for leaks.</p> <p>Drain reservoir, flush and fill with clean fluid. Change filter.</p> <p>Refer to power source operator's manual for proper adjustment of flow</p>
Saw leaks hydraulic fluid.	<p>Saw parts loose.</p> <p>Saw parts worn or damaged.</p>	<p>Tighten component hardware.</p> <p>Disassemble saw and replace worn or damaged parts.</p>
Saw control valve sticks or works hard.	<p>Check for dirt or gummy deposits.</p> <p>Misalignment or binding of control linkage.</p> <p>Valve parts damaged.</p>	<p>Clean parts.</p> <p>Correct alignment, lubricate linkage joints, and replace damaged parts.</p> <p>Disassemble valve and replace damaged parts.</p>

Saw operates, but blade does not cut.	<p>Blade loose, spinning on arbor shaft.</p> <p>Blade installed opposite to manufacturer's cutting rotation.</p> <p>Wrong blade used for material being cut.</p>	<p>Insure cap screw and arbor nut are tightened securely as described in Chapter 4.</p> <p>Check for correct cutting rotation of blade. If installed incorrectly, remove and install correctly.</p> <p>Install blade recommended by manufacturer for material to be cut.</p>
---------------------------------------	--	--



**WARNING:**

**ANY BLADE FROM YOUR SUPPLIER MUST MEET THE DESIGN CRITERIA LISTED IN CHAPTER 2. USING BLADES ON THIS SAW THAT DON'T MEET THESE REQUIREMENTS CAN CAUSE EQUIPMENT DAMAGE AND/OR PERSONAL INJURY.**

## 6 PARTS LIST

The following parts list applies to the TS14 Trenchsaw only. The parts list for the hydraulic power source is in the separate manual supplied for this item. Each item number on the following parts list can be matched with the item number shown on the Figure 6-1 assembly drawing.

Item Number	Part Number	Quantity	Description
1	5023960	1	TRIGGER LOCKOUT
2	2031480	1	TRIGGER LINKAGE
5	2031465	1	PRESSURE & RETURN HOSE KIT
10	5023970	1	TRIGGER ASSEMBLY
12	1697502	2	HOSE WHIPS 12"
13	6001886	1	COUPLING 1/2" FEMALE
14	6001885	1	COUPLING 1/2" MALE
15	7407160	1	WATER FILTER
16	5607162	1	WATER HOSE FITTING
19	6004623	1	3 PORT VALVE
21	2031490	1	SAW FRAME
22	5806245	1	HEXSCREW
23	5806407	1	TOOTH WASHER
24	5806222	2	HEXSCREW
25	5806402	4	TOOTH WASHER
27	5604684	2	FITTING 90 DEGREE
32	2000794	1	GUARD WITH DECALS
38	5806307	2	CAPSCREW
39	6420314	2	PLUG END
40	6407161	2	HANDLE GRIP
41	5806429	2	COTTER PIN
42	5820314	1	PUSH NUT
43	5806792	1	SPRING
44	5806757	1	CLEVIS PIN 1/4"x1-1/2
45	5806759	1	CLEVIS PIN 1/4"x1-3/4
46	5806111	1	LOCKNUT
47	5891400	1	SHOULDER SCREW
51	2014617	1	ARBOR WRENCH
52	2004616	1	FLANGE
53	2004000	1	ARBOR NUT—LEFT HAND
55	5806120	1	DRIVE SCREW
57	2004615	1	ARBOR & FLANGE KIT (W/ MOUNTING KIT)
58	2004633	1	ARBOR FLANGE MOUNTING KIT
59	2004644	1	VALVE BOTTOM COVER
60	2007552	1	ARBOR FLANGE REMOVAL TOOL
61	5020314	1	TRIGGER & LOCKOUT ASSY KIT W/ HDWR
62	6504932	1	MOTOR WITH MOUNTING KIT
63	7404676	1	VALVE REBUILD KIT
64	7404808	1	MOTOR SEAL KIT
65	5804659	2	NUT, BOLT, & WASHER (MOTOR MOUNT KIT)
66	2031470	1	VALVE MOUNTING HARDWARE KIT

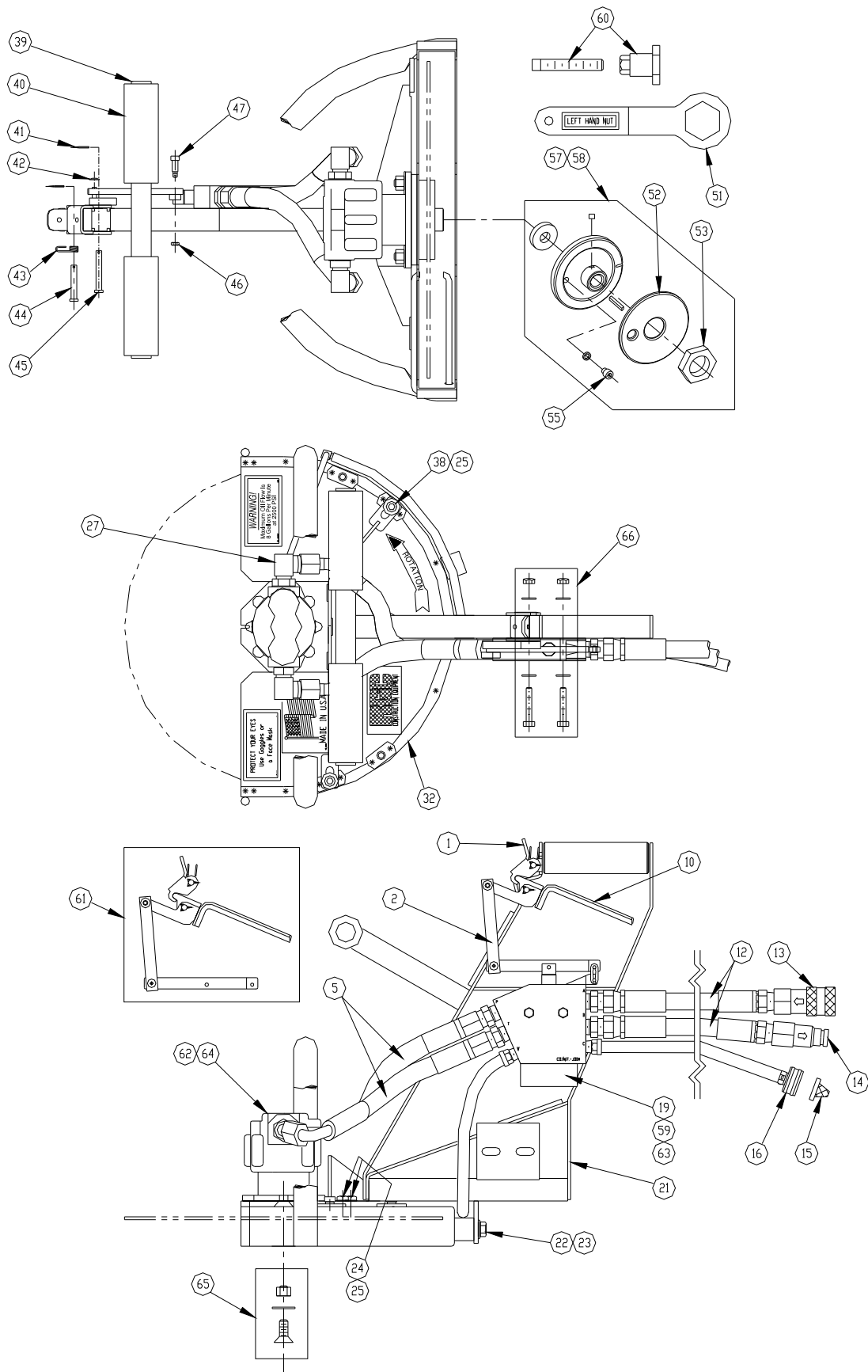

**Figure 6-1**  
**TS14 Trenchsaw Assembly**

## **LIMITED PRODUCT WARRANTY**

**Reimann & Georger Corporation  
Hoisting and Construction Products**

### **A. LIMITED WARRANTY**

Reimann & Georger Corporation (the "Manufacturer") warrants to the original purchaser (the "Buyer") that all Reimann & Georger Hoisting and Construction products shall be free of defects in material and workmanship for a period of one (1) year from date of original purchase.

### **B. MANUFACTURER'S OBLIGATIONS**

The Manufacturer's sole obligation under this Limited Warranty is the repair or, at the Manufacturer's discretion, the replacement of parts found to be defective. Parts and equipment must have authorization from the Manufacturer prior to return to the Manufacturer or repair by an authorized service person. Costs of transportation and other expenses connected with replacing or repairing parts are not covered under this Limited Warranty.

### **C. PARTS MANUFACTURED BY OTHERS**

This Limited Warranty does not cover any parts manufactured by others. Such parts are subject to the warranty, if any, of their respective manufacturers, and are to be repaired only by a respective authorized service person for such parts. The Manufacturer shall have no obligation to undertake repairs of parts manufactured by others.

### **D. NO SPECIAL, INCIDENTAL, OR CONSEQUENTIAL DAMAGES**

**IN NO EVENT SHALL THE MANUFACTURER BE LIABLE TO THE BUYER OR ANY OTHER PERSON FOR ANY INDIRECT, SPECIAL, INCIDENTAL OR CONSEQUENTIAL LOSSES OR DAMAGES CONNECTED WITH THE USE OF THE PRODUCT UNDER THIS LIMITED WARRANTY. SUCH DAMAGES FOR WHICH THE MANUFACTURER SHALL NOT BE RESPONSIBLE INCLUDE, BUT ARE NOT LIMITED TO, LOST TIME AND CONVENIENCE, LOSS OF USE OF THE PRODUCT, THE COST OF A PRODUCT RENTAL, COSTS OF GASOLINE, TELEPHONE, TRAVEL, OR LODGING, THE LOSS OF PERSONAL OR COMMERCIAL PROPERTY, AND THE LOSS OF REVENUE.**

### **E. NO LIABILITY IN EXCESS OF PURCHASE PRICE**

**IN NO EVENT SHALL THE MANUFACTURER'S OBLIGATIONS UNDER THIS LIMITED WARRANTY EXCEED THE PURCHASE PRICE OF THE PRODUCT.**

### **F. NO EXTENSION OF STATUTE OF LIMITATIONS**

**ANY REPAIRS PERFORMED UNDER THIS WARRANTY SHALL NOT IN ANY WAY EXTEND THE STATUTES OF LIMITATIONS FOR CLAIMS UNDER THIS LIMITED WARRANTY.**

### **G. WAIVER OF OTHER WARRANTIES**

**THE EXPRESS WARRANTIES SET FORTH IN THIS LIMITED WARRANTY ARE IN LIEU OF AND EXCLUDE ANY AND ALL OTHER WARRANTIES, EXPRESS OR IMPLIED, INCLUDING, BUT NOT LIMITED TO, THE IMPLIED WARRANTIES OR MERCHANTABILITY AND FITNESS FOR A PARTICULAR PURPOSE.**

## **H. PROCEDURE FOR WARRANTY PERFORMANCE**

If the product fails to perform to the Manufacturer's specifications, the Buyer must provide the Manufacturer with the applicable model and serial numbers, the date of purchase, and the nature of the problem.

### **I. ADDITIONAL EXCLUSIONS FROM THIS LIMITED WARRANTY. THIS LIMITED WARRANTY DOES NOT COVER ANY OF THE FOLLOWING:**

1. Equipment which has been abused, damaged, used beyond rated capacity, or repaired by persons other than authorized service personnel.
2. Damage caused by acts of God which include, but are not limited to, hailstorms, windstorms, tornadoes, sandstorms, lightning, floods, and earthquakes.
3. Damage under conditions caused by fire or accident, by abuse or by negligence of the user or any other person other than the Manufacturer, by improper installation, by misuse, by incorrect operation, by "normal wear and tear", by improper adjustment or alteration, by alterations not completed by authorized service personnel, or by failure of product parts from such alterations.
4. Costs of repairing damage caused by poor or improper maintenance, costs of normally scheduled maintenance, or the cost of replacing any parts unless done as the result of an authorized repair covered by the one (1) year Limited Warranty.
5. Costs of modifying the product in any way once delivered to the Buyer, even if such modifications were added as a production change on other products made after the Buyer's product was built.

### **J. NO AUTHORITY TO ALTER THIS LIMITED WARRANTY**

No agent, representative, or distributor of the Manufacturer has any authority to alter the terms of this Limited Warranty in any way.