



# HYDRAULIC HAND- HELD CHAIN SAW INSTRUCTIONS

REIMANN & GEORGER CORPORATION  
CONSTRUCTION PRODUCTS

BUFFALO, NY

LE 03/12/10F

# TABLE OF CONTENTS

<b>Title</b>	<b>Page</b>
Safety .....	1
Important Safety Information .....	2
Disassembly .....	4
Inspection.....	6
Assembly.....	6
Adjustments .....	9
Sharpening the Saw Chain.....	10
Illustration.....	12
Parts List.....	13

## **SAFETY**

Safety is essential in the use and maintenance of RGC tools and equipment. This service manual and any markings on the tool provide information for avoiding hazards and unsafe practices related to the use of this tool. Observe all of the safety information provided. Keep this manual available to all personnel. Replacement manuals are available upon request at no charge at [www.rgcproducts.com](http://www.rgcproducts.com).

**KEEP THIS MANUAL**

# IMPORTANT SAFETY INFORMATION



## SAFETY ALERT SYMBOL

This symbol is used to call your attention to hazards or unsafe practices which could result in an injury or property damage. The signal word, defined below, indicates the severity of the hazard. The message after the signal word provides information for preventing or avoiding the hazard.

### **⚠ DANGER**

Immediate hazards which, if not avoided, WILL result in severe injury or death.

### **⚠ WARNING**

Hazards which, if not avoided, COULD result in severe injury or death.

### **⚠ CAUTION**

Hazards or unsafe practices which, if not avoided, MAY result in injury or property damage.



### **⚠ WARNING**

Read and understand all of the instructions and safety information in this manual before operating or servicing this tool.

### **⚠ WARNING**



Skin injection hazard:

- Do not use hands to check for leaks.
- Do not hold hose or couplers while the hydraulic system is pressurized.
- Depressurize the hydraulic system before servicing.

Oil under pressure easily punctures skin causing serious injury, gangrene or death. If you are injured by escaping oil, seek medical attention immediately.

### **⚠ WARNING**



Wear eye protection when operating or servicing this tool.

Failure to wear eye protection could result in serious eye injury from flying debris or hydraulic oil.

### **⚠ WARNING**



Wear hearing protection when using this tool.

Failure to observe this warning could result in serious injury.

### **⚠ WARNING**



Wear foot protection when using this tool.

Failure to observe this warning could result in serious injury.

# IMPORTANT SAFETY INFORMATION

	<b>⚠ WARNING</b>
	Tool, chain, and other components may be hot during and after operation. Allow to cool before handling, or handle with heat-resistant gloves. Failure to observe this warning could result in severe injury.

<b>⚠ WARNING</b>
Do not change accessories, inspect, adjust or clean tool when it is connected to a power source. Accidental startup can result in serious injury. Failure to observe this warning could result in severe injury or death.

<b>⚠ WARNING</b>
Do not exceed the maximum hydraulic flow, pressure relief or back pressure listed in the Specifications and Parts manual. Failure to observe this warning could result in severe injury or death.

<b>⚠ CAUTION</b>
Hydraulic oil can cause skin irritation. <ul style="list-style-type: none"><li>• Handle the tool and hoses with care to prevent skin contact with hydraulic oil.</li><li>• In case of accidental skin contact with hydraulic oil, wash the affected area immediately to remove the oil.</li></ul> Failure to observe these precautions may result in injury.

<b>⚠ WARNING</b>
Do not disconnect tool, hoses or fittings while the power source is running or if the hydraulic fluid is hot. Hot hydraulic fluid could cause serious burns.

<b>IMPORTANT</b>
Procedure for connecting or disconnecting hydraulic hoses, fittings or components: <ol style="list-style-type: none"><li>1. Move the flow lever on the power source to the OFF position.</li><li>2. Stop the hydraulic power source.</li><li>3. Follow the sequence under Hose Connections to prevent pressure buildup. In case some pressure has built up, loosen hoses, fittings or components slowly.</li></ol>

<b>⚠ WARNING</b>
Do not reverse hydraulic flow. Operation with hydraulic flow reversed can cause tool malfunction. Connect the supply (pressure) hose and return (tank) hose to the proper ports.

*Note: Keep decals clean and legible. Replace when necessary — see the decals listed in the Parts and Specifications manual.*

## Disassembly

Complete disassembly of the tool is not recommended. If a complete overhaul is necessary, return the tool to your nearest Fairmont Authorized Fairmont Service Center.

The disassembly procedure is divided into sections of the tool. Disassemble only the section(s) necessary to complete the repair.

Disassemble the tool on a flat, clean surface. Take care not to lose or damage any parts that may fall free during disassembly.

### Saw Chain, Guide Bar, and Cover

1. Mark the top side of the guide bar with a grease pencil or marker.
2. Remove the two cover knobs (53) and cover (52).
3. Loosen the two 5/16–18 flange nuts (51). Turn the #10–24 chain adjusting screw (60) to loosen the chain. Remove the two flange nuts (51).
4. Pull the saw chain (54) off the rim sprocket (47), and remove the guide bar (55) and chain (54).
5. Remove the adjusting screw (60) and dog (59), if necessary.

### Rim Sprocket and Spline Adapter

Hold the rim sprocket (47), using a spanner wrench or similar tool. Loosen and remove the 1/2" elastic stop nut (49), washer (48), sprocket (47), spline adapter (45), spacer (44), and Woodruff key (34).

### Lower Handle and Front Handle

1. Remove one 1/4–20 x .625 button head cap screw (43) from the rear of the lower handle (2), and 1/4–20 lock nut (4) and 1/4–20 x 1.5 button head cap screw (3) from the front of the lower handle to separate from the main handle.
2. Remove two 1/4–20 x .750 button head cap screws (38) from the top of the front handle (37) and one 1/4–20 x .625 button head cap screw (43) from the bottom of the front handle to separate from the mount plate (40).

### Chain Brake Assembly

1. Loosen the lock screw on the Bowden pin (68) to ensure the cable (70) can slide easily within the pin. Push the front shroud (39) forward.
2. Remove one #8–32 hex lock nut (76) and #8–32 screw (75) holding the toggle (74) to the rod (62).
3. Remove one .372 dia. x 1 socket head shoulder screw (71) and separate the front shroud (39), two washers (67), and toggle (74) from the mount plate (40).
4. Remove one 1/4–20 hex lock nut (69) from the end of the rod (62) and slide the rod, spring (72), and hex lock nut (73) out of the bracket (64), only if necessary. Remove two 1/4–20 x .38 button head cap screws (66) to separate the bracket from the mount plate.
5. Remove two 1/4–20 x .25 button head cap screws (63) to separate the push-pull cable (70) and cable clamps from the mount plate. Remove the cable from the lever (81) located in the end of the spool (77).
6. Remove one #10–32 x .38 button head cap screw (82) from the end of the spool and remove the lever.
7. Remove the retaining ring (80) from the end of the spool and push the spool out of the spool bore.

### Trigger

1. Remove one .156 dia. x 1" roll pin (9) from the interface of the link (19) and spool (18).
2. Remove one .156 dia. x 1" roll pin (9) that holds the trigger (20) into the main handle and remove the trigger, only if necessary.
3. Remove one .156 dia. x .5 roll pin (10) from the interface of the link (19) and trigger (20) to separate components, only if necessary.
4. Remove two .156 dia. x 1" roll pins (9) from the handle and remove the trigger actuator and spring (12), only if necessary. Observe proper seating of spring prior to removal.
5. Remove the washer (17) and spring (16) from the end of the spool (18).

### Control Spool and Sleeve

1. Remove the 7/8" external retaining ring (14) from the end of the sleeve (7). Pull the sleeve and spool (18) as an assembly out of the sleeve bore. Remove the O-ring (13) from the inside of the sleeve bore.
2. Remove one 5/16–18 x .375 button head cap screw (5) from the end of the spool (18). Remove the spool (18) from the sleeve (7).
3. Remove the two O-rings (6, 8) from the sleeve; remove the O-ring (15) from the end of the spool (18).

## Disassembly (cont'd)

### Oil Metering Screw

Remove the oil metering screw (30) from the saw head (1). Remove the O-ring (31) from the metering screw.

### Saw Head Body/Mount Plate

1. Remove the four 1/4-20 x .625 button head cap screws (43) to remove the saw head body (1) from the mount plate (20).
2. Remove the two standoffs (46) and two 5/16-18 x 1" studs (50) from the mount plate (20), only if necessary.
3. Remove one 1/4-20 x .625 (43) and one 1/4-20 x .750 (38) button head cap screw and one 1/4-20 lock nut (4) to remove the spike rack (41) and chain catcher (61) from the mount plate (20), only if necessary.

### Saw Head and Motor

1. Scribe a line across the motor cap (22) and saw head motor body (1) to align the parts correctly during reassembly.
2. Remove eight 1/4 x 1" socket head cap screws (21). Pull the motor cap (22) from the saw head motor body (1). Remove the gasket (25).
3. Pull the idler shaft (27) with the gear (26) out of the saw head motor body. Remove the gear (26) from the idler shaft (27). Remove the drive pin (28) from the idler shaft, if necessary.
4. Remove the gear (26) and Woodruff key (33) from the drive shaft (32).
5. Remove the 1-3/8" internal retaining ring (36). Remove the drive shaft (32) and bearing (35) from the bar side of the saw head. The bearing is pressed in. Remove the bearing (35) from the drive shaft (32), only if necessary.
6. Pull the two dowel pins (23) out of the saw head motor body, only if necessary.
7. Remove the O-ring (29) in the saw head motor body (1). The O-ring can be removed with the needle bearing (24) in place using an O-ring tool.

## Inspection

Clean all parts with an appropriate cleaning solution and dry them thoroughly. Inspect each component as described in this section. Replace any component that shows wear or damage.

1. Ball Bearing (35): Hold the center hub between your thumb and index finger. Roll the outer surface against the palm of your other hand. Replace the bearing if it does not rotate smoothly.
2. Needle Bearings (24): Insert shaft into bearings. Spin shaft. If the shaft does not spin smoothly, replace the entire assembly with bearings already pressed in.
3. Saw Head Motor Body (1) and Motor Cap (22): Inspect mating surfaces, bores, oil passageways, etc. for grooves or nicks. If any component shows wear or damage, replace the entire assembly with bearings already pressed in.
4. Rim Sprocket (47) and Adapter (45): Inspect all surfaces, including gear teeth, for grooves or chips. A minor amount of wear, if it's consistent among all of the teeth (an even wear pattern), is acceptable. The rim sprocket and adapter function as a unit. If one of them needs to be replaced, replace both of them. Also, replace the saw chain at the same time.
5. Guide Bar (55): Clean the oil passage at the base of the guide bar. Use any instrument small enough to thoroughly clean the passage. Check the bar rails for wear by placing a straight edge against the side of the bar and one cutter.
  - Clearance between the bar and the straight edge indicates that the bar rails are not worn.
  - If the chain leans and there is little or no clearance between the bar and the straight edge, the bar rails are worn and the bar should be replaced.

### Checking the Rails for Wear

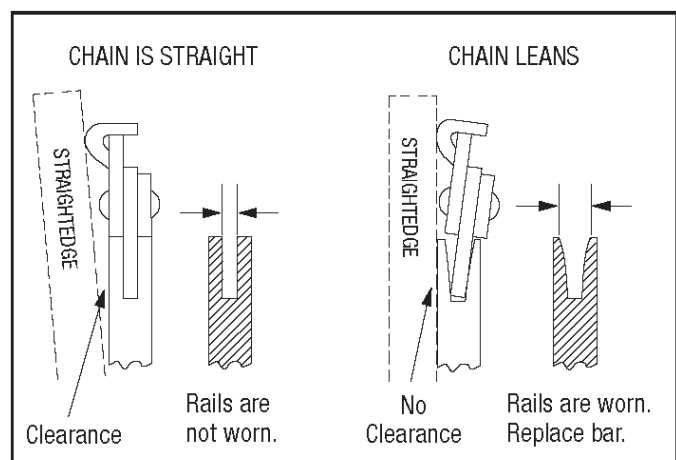

6. Inspect all other disassembled components for cracks, grooves or nicks.

## Assembly

Refer to the Illustration and Parts List for correct orientation and placement of parts.

Replace any O-rings and gaskets on parts that have been disassembled. Apply hydraulic fluid or O-ring lubricant to all O-rings and all metal surfaces which they must slide over. When installing an O-ring which must slide over sharp surfaces, use a rolling motion and be careful not to damage the O-ring.

Wherever the assembly results in metal-to-metal contact, coat the surfaces with hydraulic fluid or O-ring lubricant.

### Saw Head and Motor

1. Install a new O-ring (29) in the saw head motor body (1) using an O-ring tool. Be careful not to damage the O-ring during installation.
2. Install the two dowel pins (23) in the saw head motor body, if they were removed. Install the gasket (25).
3. Press the bearing (35) on the drive shaft (32). Generously lubricate the drive shaft and install the drive shaft and bearing in the saw head motor body. Press the bearing into place. Secure with a 1-3/8" internal ring (36).
4. Install the Woodruff key (33) and one gear (26) on the drive shaft (32).
5. Install the drive pin (28) in the idler shaft (27), if it was removed. Slide one gear (26) on the idler shaft (15). Install the idler shaft with the gear (26) in the saw head motor body.
6. Install the motor cap (22) on the saw head motor body (1), aligning the scribe marks that were made during disassembly.
7. Secure the motor cap using eight 1/4 x 1" socket head cap screws (21). Torque the cap screws to 10 Newton-meters (90 in-lb).

Torque Sequence

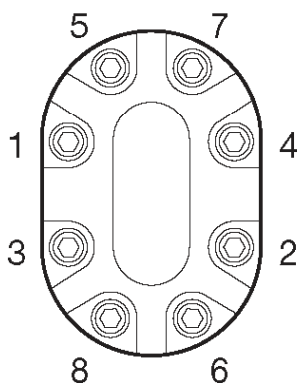

### Metering Screw

Install a new O-ring (31) on the metering screw (30). Install the metering screw (30) in the saw head (1).

### Trigger Actuator, Spring, Trigger, Control Spool, and Sleeve

1. If removed, ensure proper seating of the spring (12) prior to installation of the trigger actuator (11). One end of the spring must be seated over the cast feature near the end of the slot on the bottom of the handle (1). The other end fits over the feature on the trigger actuator as shown in the Illustration.
2. Secure the trigger actuator in place using two .156 dia. x 1" roll pins (9).
3. If removed, attach the link (19) to the trigger (20) using one .156 dia. x .5 roll pin (10).
4. If removed, install the trigger/link assembly (20/19) into the slot in the bottom of the handle (1) and secure in place using one .156 dia. x 1" roll pin (9).
5. Install two new O-rings (6, 8) on the sleeve (7). Install one new O-ring (13) into the sleeve bore of the saw head body (1).
6. Install a new O-ring (15) onto the spool (18) and install the spool into the sleeve (7).
7. Secure the spool (18) into the sleeve (7) using one 5/16-18 x .375" button head cap screw (5). Apply a thread-locking compound, such as Loctite 242 Threadlocker or equivalent, to the cap screw (5). Follow the manufacturer's instructions for applying and curing.
8. Install the sleeve and spool assembly into the sleeve bore in the saw head body (1). Secure using one 7/8" external retaining ring (14).
9. Install the spring (16) and washer (17) onto the end of the spool (18).
10. Depress the washer (17) and spring (16) and secure the link (19) to the end of the spool (18) using one .156 dia. x 1" roll pin (9).

## Assembly (cont'd)

### Mount Plate, Spike Rack, Standoffs, and Studs

1. If the two standoffs (46) or the two 5/16–18 x 1 studs (50) were removed, clean the thread-locking compound from all internal and external threads and apply a small amount of retaining compound, such as Loctite® 609 or equivalent, to the threads and reinstall the components. Follow the manufacturer's instructions for applying and curing.
2. If the 1/4–20 x .625 (43) and 1/4–20 x .750 (38) button head cap screws, 1/4–20 lock nut (4), chain catcher (61), and spike rack (41) were removed, clean the thread-locking compound from all internal and external threads and apply a small amount of thread-locking compound, such as Loctite® 242® Threadlocker or equivalent, to the threads and reinstall the components. Follow the manufacturer's instructions for applying and curing.

### Motor Housing/Mount Plate, Drive Shaft Components, Bar, and Chain

1. Assemble the motor housing/handle assembly to the mount plate. Rotate the handle assembly relative to the mount plate to the desired handle orientation. The chain saw handle can be assembled in the horizontal position, relative to the bar, with the four hole locations identified in the figure as location #1. The 30° handle orientation corresponds with hole location #2, while the 60° position corresponds with hole location #3. Prior to installing the button head cap screws (43), clean the internal and external threads and apply a small amount of thread-locking compound, such as Loctite® 242® Threadlocker or equivalent, to the threads in the mount plate (40) and also to the screw threads (43). Follow the manufacturer's instructions for applying and curing. Tighten the screws to 9 to 10 Newton-meters (80 to 90 in-lb).

Handle Position

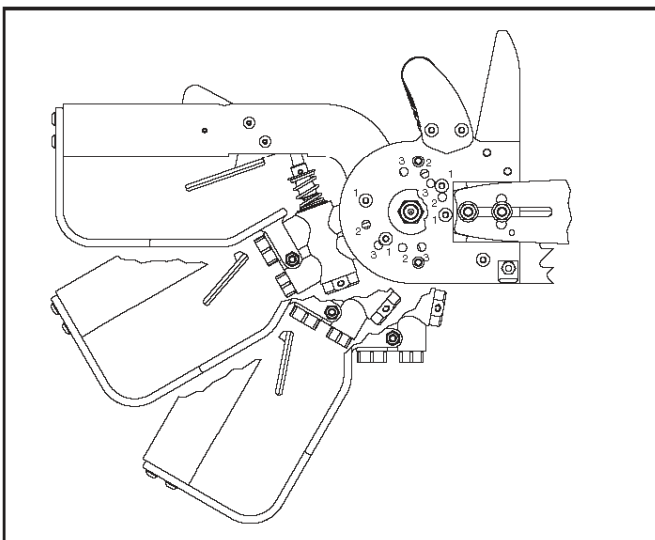

2. Install the Woodruff key (34), drive shaft spacer (44), spline adapter (45), rim sprocket (47), washer (48), and lock nut (49) onto the drive shaft. Holding the sprocket with a spanner wrench or similar tool, tighten the lock nut (49) securely.
3. Install the adjustment dog (59) and fillister head adjustment screw (60), if removed. Using the mark made during disassembly for reference, turn the bar upside down so it will wear evenly. Install the bar (55) and chain (54) onto the mount plate pad and secure loosely with two 5/16–18 flange nuts (51). Verify that the chain is installed as shown. Ensure that the adjustment dog (59) is located in the appropriate hole in the bar (55).

Bar Installation

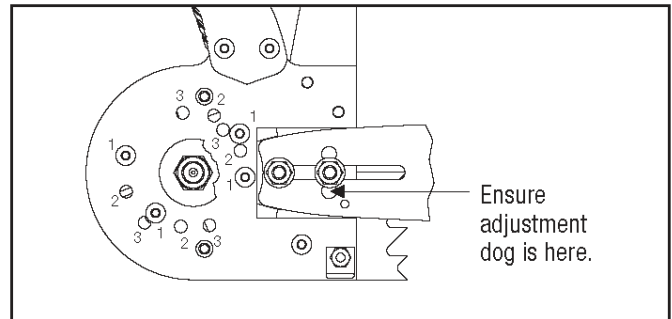

Direction of Chain Travel

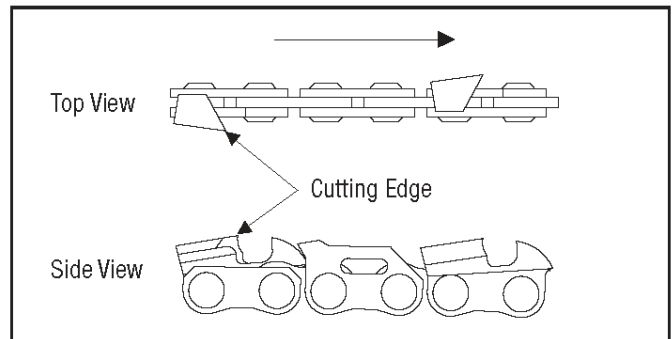

4. Tighten the chain (54) using the adjustment dog (59) and fillister head adjustment screw (60) per Adjusting Chain Tension in the Adjustments section of this manual. Tighten the flange nuts to 16.9 Newton-meters (150 in-lb).

## Assembly (cont'd)

### Front Handle, Lower Handle, and Cover

1. Prior to installing the button head cap screws, clean the internal and external threads and apply a small amount of thread-locking compound, such as Loctite 242 Threadlocker or equivalent, to the threads in the mount plate (40) and also to the screw threads. Follow the manufacturer's instructions for applying and curing.
2. Locate the front handle in the appropriate position and secure the top of the handle with two 1/4-20 x .750 button head cap screws (38) and the bottom with one 1/4-20 x .625 button head cap screw (43).
3. Locate the lower handle in the appropriate position and secure the front with one 1/4-20 x 1.5 button head cap screw (3) and lock nut (4). Secure the rear of the lower handle to the end of the cast handle, using two 1/4-20 x .625 button head cap screws (43).
4. Install the cover (52) over the standoffs (46) and secure in place with two cover knobs (53).

### Chain Brake Assembly

1. Install the spool (77) into the spool bore, ensuring that the holes through the spool align with the fluid passages in the bore. Install the retaining ring (80) into the ring groove on the end of the spool.
2. Install the lever (81) over the end of the spool so that when the lever is rotated toward the handle, the spool rotates within the bore. Secure in place using one #10-32 x .38 button head cap screw.
3. Install the z-bend end of the push-pull cable (70) into the hole in the lever and secure the cable assembly to the mount plate (40) using two 1/4-20 x .25 button head cap screws (63).
4. Secure the bracket (64) and rod assembly to the mount plate using two 1/4-20 x .38 button head cap screws (66). If the rod, spring, hex nuts, and bracket were disassembled, reassemble and adjust according to the dimensions in the figure below. Adjust with the shroud pulled rearward.

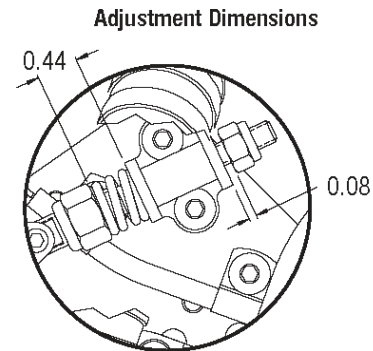

5. Slide the cable through the hole in the Bowden pin (68). Secure the front shroud (39) and two washers (67) to the mount plate using one .372 dia. x 1.25 socket head shoulder bolt (71).
6. With the shroud in the forward position, attach the toggle (74) to the end of the rod (62), using one #8-32 x .75 socket head cap screw (75) and one #8-32 hex lock nut (76).
7. Pull the shroud (40) rearward to lock in place and tighten the locking screw on the Bowden pin (68).

## Adjustments

### Checking and Setting the Automatic Chain Oiler

The automatic chain oiler provides a constant supply of oil to lubricate the bar and chain whenever the saw is operating. An adjustment screw controls the amount of oil supplied.

1. Run the saw at full rpm.
2. If the tip of the saw gives off a fine spray of oil, the automatic oiler is working properly. If the saw does not give off a spray of oil, adjust the oiler.

*Note: For better results, hold saw so that the tip of the saw blade is pointing toward a clean sheet of paper or cardboard and run the saw at full rpm. If the automatic oiler is working properly, the paper or cardboard should soon show small droplets of oil.*

3. Stop the hydraulic power source.
4. Twist the adjustment screw 1/2 turn as follows:
  - clockwise to decrease the oiler output.
  - counterclockwise to increase the oiler output.

Automatic Oiler Adjustment Screw

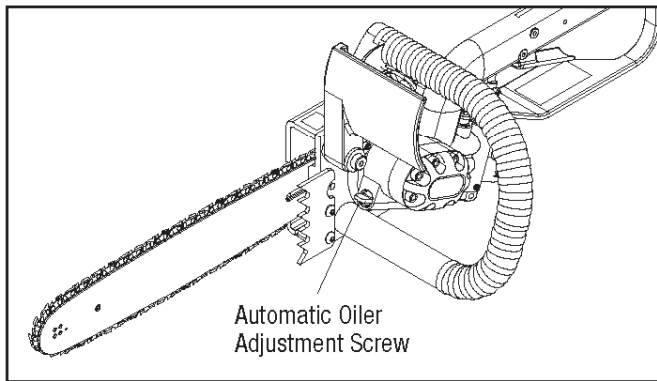

5. Start the hydraulic power source.
6. Repeat until the oiler output is adjusted correctly.

### New Chain Break-In

1. Run the saw at low chain speed without cutting wood for 2 to 3 minutes. Check the output from the automatic oiler.
2. Stop the hydraulic power source. Disconnect the hoses. Allow the bar and chain to cool. Check the tension and adjust if necessary.
3. Connect the hoses. Start the power source. Make a few easy cuts at moderate chain speed.
4. Stop the hydraulic power source. Disconnect the hoses. Allow the bar and chain to cool. Check the tension and adjust if necessary.
5. Connect the hoses. Start the power source. Use the saw for moderate cuts during the next 30 minutes of use.

### Checking Chain Tension

1. Stop the hydraulic power source. Disconnect the hoses. Allow the bar and chain to cool.
2. Pull the saw chain around the bar. The chain should rotate around the bar easily. If it does not, see Chain is Difficult to Rotate Manually in the Troubleshooting table.
3. Check the tension as follows:

Pull the saw chain away from the bar (see the illustration) using approximately 4.4 Newtons (2 lb) of force. The clearance between the chain and bar should be approximately 3.2 mm (1/8"). If there is too much or too little clearance, proceed to Adjusting Chain Tension.

Proper Chain Tension

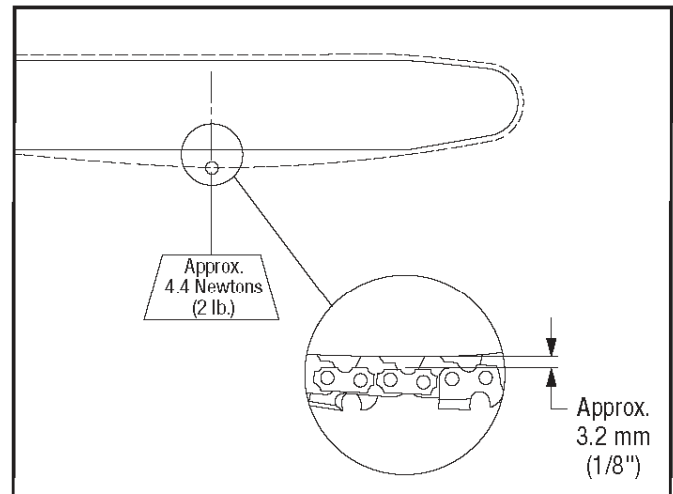

### Adjusting Chain Tension

1. Loosen the two bar flange nuts.
2. Turn the saw chain tension adjusting screw until the proper tension is achieved, as follows:

Pull the saw chain away from the bar (see the illustration) using approximately 4.4 Newtons (2 lb) of force. The clearance between the chain and bar should be approximately 3.2 mm (1/8").
3. Hold the bar nose up and tighten the two bar flange nuts. Torque to 16.9 Newton-meters (150 in-lb).
4. Check the chain tension again.
5. Rotate the chain around the bar manually. If you hear a clicking noise, the chain drive links are hitting the bar. Repeat the Adjusting Chain Tension procedure.

## Sharpening the Saw Chain

The saw chain must be sharpened to the manufacturer's specifications. If the saw chain is not properly sharpened, the risk of kickback increases.

If using a filing guide or hand-held grinder, refer to the manufacturer's instructions provided with the unit.

See Illustration →		Figure A	Figure B	Figure C	Figure D	Figure E	—	Figure F	—
Model Number	Chain Part Number	Pitch	Gauge	Side Plate Angle	Top Plate Cutting Angle	Top Plate Filing Angle	File Guide Angle	Depth Gauge Setting	Round File Size
HPS513CB	50433709	.325"	.058"	60°	60°	25°	90°	.025"	5/32"
HCS513XCB	50433709	.325"	.058"	60°	60°	25°	90°	.025"	5/32"
HPS516XCB	50482661	.325"	.058"	60°	60°	25°	90°	.025"	5/32"
HCS520XCB	90551893	.325"	.058"	60°	60°	25°	90°	.025"	5/32"
HCS816XCB	50419600	3/8"	.050"	85°	60°	30°	90°	.030"	3/16"
HCS820XCB	90551915	3/8"	.050"	85°	60°	30°	90°	.030"	3/16"
HCS824CB	90551923	3/8"	.050"	85°	60°	30°	90°	.030"	3/16"

### Saw Chain Pitch

See Figure A. Pitch refers to the saw chain measurement. A chain's pitch is the distance between any three consecutive rivets divided by two. Example: .65 divided by two equals .325 pitch.

Figure A Pitch

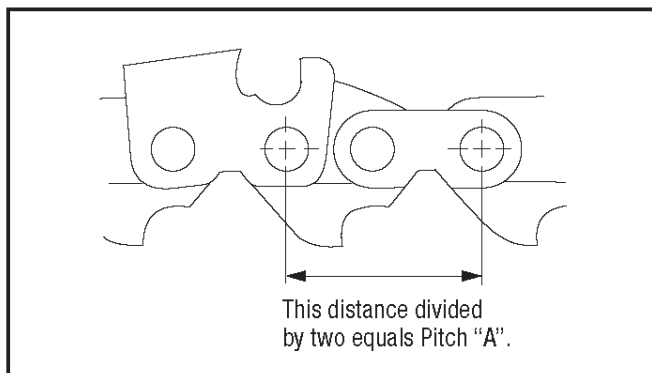

### Saw Chain Gauge

See Figure B. Gauge refers to the thickness of that portion of the drive link which fits into the guide bar groove. The guide bar and saw chain gauge must match. Industry standards are .050, .058 and .063.

Figure B Gauge

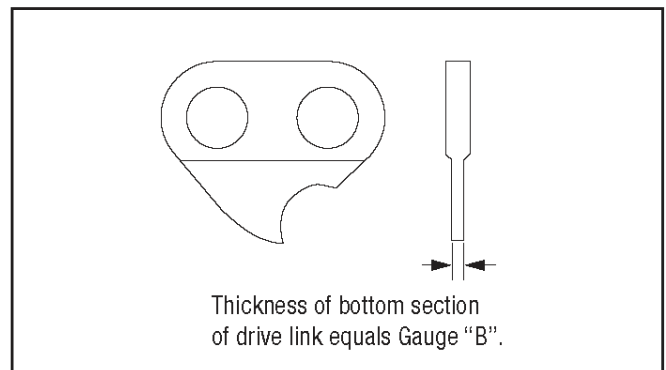

Figure C  
Side Plate Angle

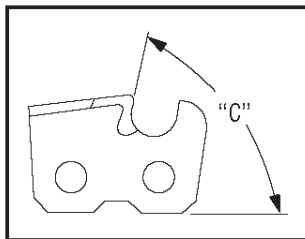

Figure D  
Top Plate Cutting Angle

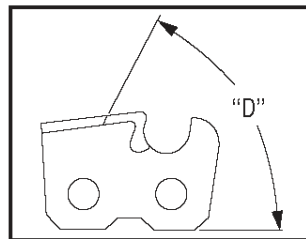

Figure E  
Top Plate Filing Angle

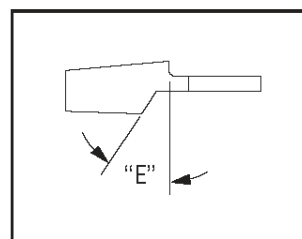
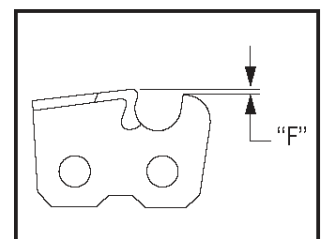

Figure F  
Depth Gauge Setting



## Sharpening the Saw Chain (cont'd)

### Filing Depth Gauges

1. If the cutters are sharpened with a file holder, check and lower the depth gauges before sharpening the cutters.
2. Check the depth gauges every third sharpening.
3. Place the depth gauge tool on the cutter. If the depth gauge projects, file it level with the top of the tool. Always file from the inside of the saw chain toward an outside cutter.

Lowering Depth Gauges

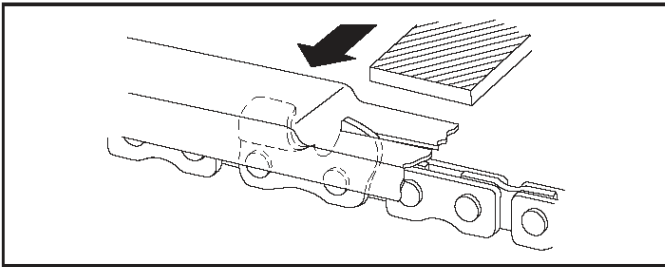

4. Round off the front corner to maintain the original shape of the depth gauge after using the depth gauge tool. Always follow the recommended depth gauge setting of the chain manufacturer. This is important for maximum performance throughout the saw chain's life as well as for protection against kickback.

Rounding Off Depth Gauges

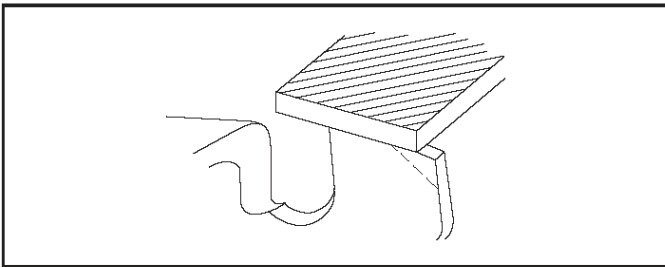

### Filing Cutters — General

1. Support the file holder on the cutter top plate and depth gauge as shown.

Filing Cutters

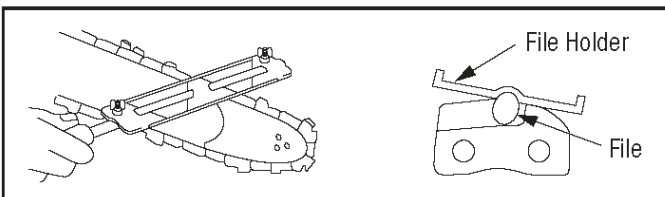

2. File the cutters on one side of the saw chain from the inside out. File on the forward stroke only.

Filing Cutters

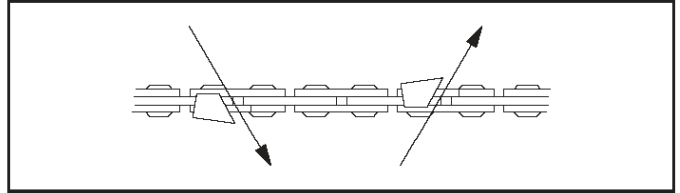

3. Keep the line on the file holder parallel to the center of the saw chain. Reverse the procedure for the other side.

Filing Cutters

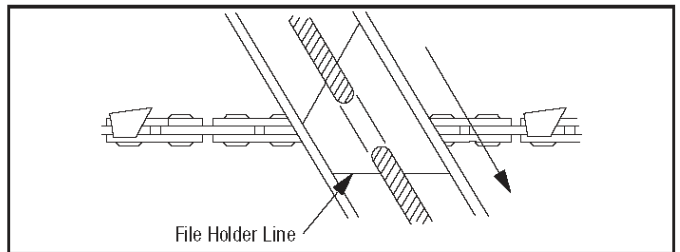

4. Keep all cutters the same length.

Filing Cutters

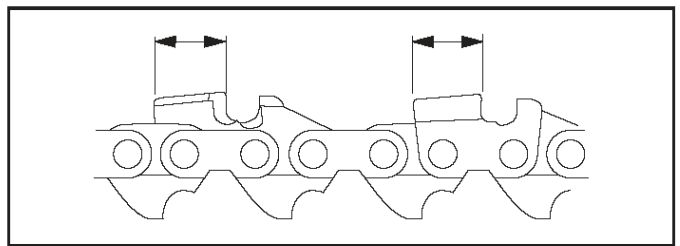

5. File enough to remove any damage to the cutting edges (side plate and top plate) of the cutter.

Filing Cutters

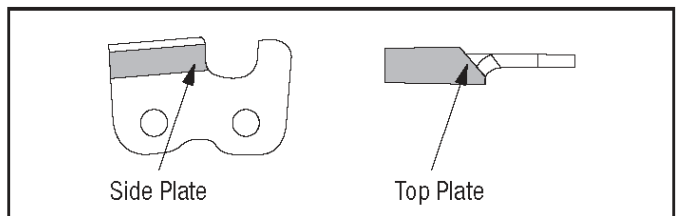

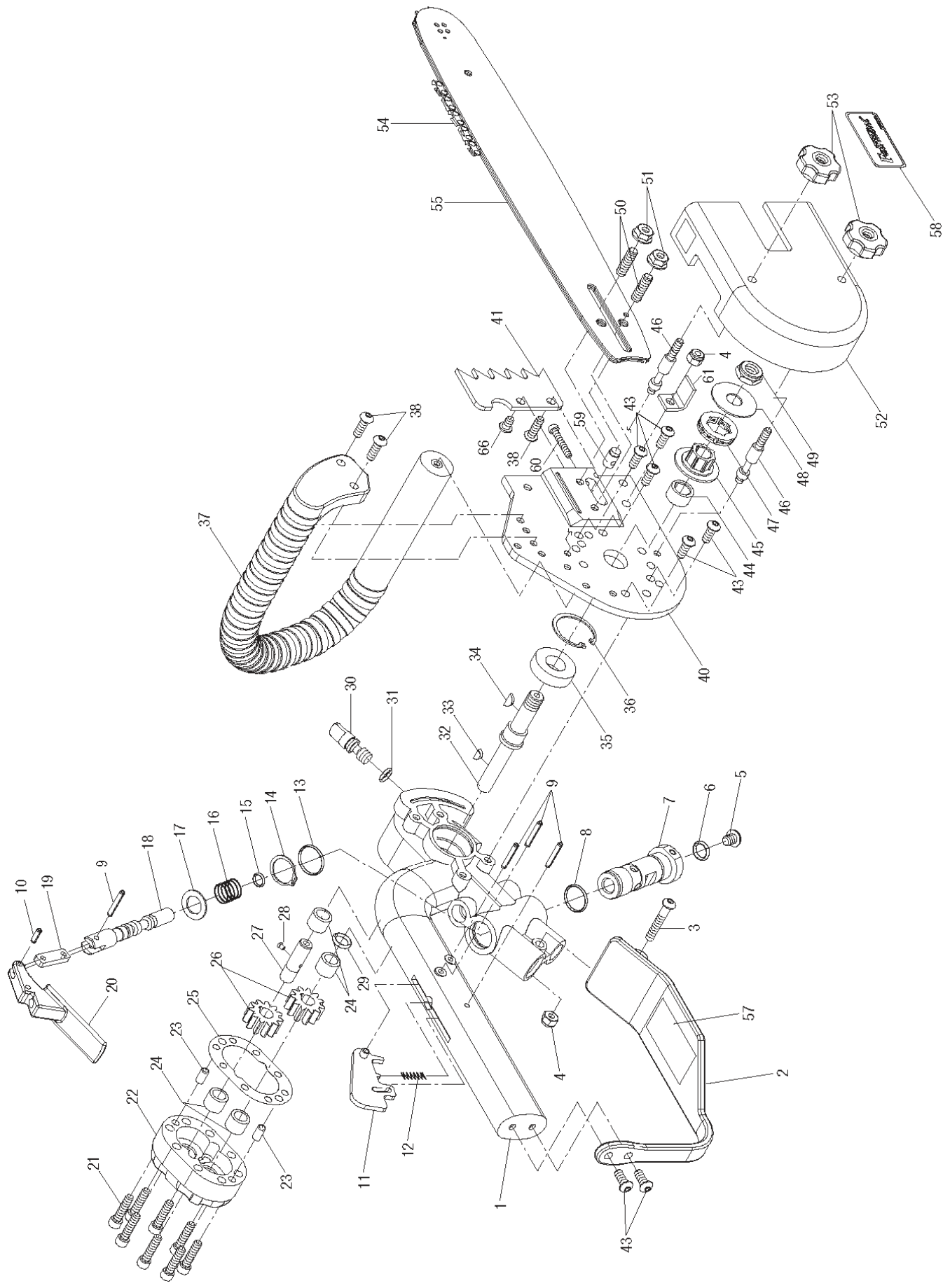

# PARTS

Key	Part No.	Description	Qty
1	50499262	Head, saw .....	1
2	50497570	Handle, lower, with decal .....	1
3	50441329	Screw, cap, 1/4-20 x 1.50", button head socket .....	1
4	50439979	Nut, hex, 1/4-20 lock, stainless steel .....	2
5	50418141	Screw, cap, 5/16-18 x .375" button head socket .....	1
6 *	50413712	O-ring, .437" x .625" x .093"-90 .....	1
7	50494155	Sleeve .....	1
8 *	50415342	O-ring, .750" x .875" x .062"-90 .....	1
9	50436228	Pin, roll, .156" x 1.00" .....	4
10	90501969	Pin, roll, .156" x .500" .....	1
11	50494082	Actuator, trigger .....	1
12	90541448	Spring, compression, .248" x .300" x .690" .....	1
13 *	50415590	O-ring, .875" x 1.00" x .062"-70 .....	1
14	90548191	Ring, retaining, .875", external .....	1
15 *	50415850	O-ring, .312" x .437" x .062"-70 .....	1
16	50417601	Spring, compression, .675" x .845" x 1.25" .....	1
17	50404622	Washer, flat, .580" x .937" x .050", stainless steel .....	1
18	50494163	Spool .....	1
19	50494090	Link .....	1
20	50494074	Trigger .....	1
21	50416162	Screw, cap, 1/4-20 x 1.00", socket head .....	8
22	50404124	Cap, motor (includes 2 of Item 24) .....	1
23	50415960	Pin, dowel, .250" x .500" .....	2
24	50415911	Bearing, needle, .439" x .625" x .500" .....	4
25 *	50415950	Gasket, 2.09" x 3.09" x .0015" .....	1
26	50416302	Gear, 11-tooth .....	2
27	50401682	Shaft, idler .....	1
28	50415930	Pin, drive, .123" x .209" w/ square head .....	1
29 *	50415033	O-ring, .500" x .687" x .093"-80 .....	1
30	50494198	Bleed screw .....	1
	50401891	Bleed screw (HPS513CB) .....	1
31 *	50413313	O-ring, .375" x .500" x .062"-70 .....	1
32	50494171	Shaft, drive .....	1
33	50415921	Key, Woodruff #213 .....	1
34	50418131	Key, Woodruff #2 .....	1
35	50415981	Bearing, ball .....	1
36	50414821	Ring, retaining .....	1
37	50494040	Handle, front .....	1
38	50419661	Screw, cap, 1/4-20 x .750", button head .....	3
39	50498975	Shroud .....	1
40	50454323	Plate, mount .....	1
41	50494031	Rack, spike .....	1
43	90540441	Screw, cap, 1/4-20 x .625", button head .....	10
44	50494180	Spacer, drive shaft .....	1
45	90551028	Adapter, sprocket .....	1
46	90551370	Standoff .....	2
47	90551010	Rim sprocket, .325" pitch (HPS513CB, HCS5XXXCB) .....	1
	90551036	Rim sprocket, 3/8" pitch (HCS8XXXCB) .....	1
48	50433091	Washer, flat, .530" x 1.50" x .050" .....	1
49	50414931	Nut, hex, 1/2-20, lock .....	1
50	90551044	Stud, threaded, 5/16-18 x 1.00" .....	2
51	90551389	Nut, hex, 5/16-18, flange .....	2
52	50494058	Cover .....	1
53	90550994	Knob, knurled, 1/4-20 x 1.00" .....	2
54	50433709	Chain, 13" x .058" Ga., .325" pitch (HPS513CB and HCS513XCB) .....	1
	50482661	Chain, 16" x .058" Ga., .325" pitch (HCS516XCB) .....	1
	50419600	Chain, 16" x .050" Ga., 3/8" pitch (HCS816XCB) .....	1
	90551893	Chain, 20" x .058" Ga., .325" pitch (HCS520XCB) .....	1
	90551915	Chain, 20" x .050" Ga., 3/8" pitch (HCS820XCB) .....	1
	90551923	Chain, 24" x .050" Ga., 3/8" pitch (HCS824XCB) .....	1
55	50433695	Bar, guide, 13" x .058" Ga (HPS513CB and HCS513XCB) .....	1
	90551800	Bar, guide, 16" x .058" Ga (HCS516XCB) .....	1
	90551419	Bar, guide, 16" x .050" Ga (HCS816XCB) .....	1
	90551826	Bar, guide, 20" x .058" Ga (HCS520XCB) .....	1
	90551850	Bar, guide, 20" x .050" Ga (HCS820XCB) .....	1
	90551869	Bar, guide, 24" x .050" Ga (HCS824XCB) .....	1
59	50494619	Dog, adjustment .....	1
60	90551397	Screw, #10-24 x 2.00", fillister head .....	1
61	50494147	Catcher, chain .....	1
<b>Decals</b>			
56*	50495674	Decal, warning .....	1
57*	50495682	Decal, pressure, flow .....	1
58	50415471	Decal, Fairmont .....	1
<b>Repair Kit</b>			
*	50407891	Packing kit (includes all items marked with an asterisk) .....	1

## **LIMITED PRODUCT WARRANTY**

**Reimann & Georger Corporation  
Hoisting and Construction Products**

### **A. LIMITED WARRANTY**

Reimann & Georger Corporation (the “Manufacturer”) warrants to the original purchaser (the “Buyer”) that all Reimann & Georger Hoisting and Construction products shall be free of defects in material and workmanship for a period of one (1) year from date of original purchase.

### **B. MANUFACTURER’S OBLIGATIONS**

The Manufacturer’s sole obligation under this Limited Warranty is the repair or, at the Manufacturer’s discretion, the replacement of parts found to be defective. Parts and equipment must have authorization from the Manufacturer prior to return to the Manufacturer or repair by an authorized service person. Costs of transportation and other expenses connected with replacing or repairing parts are not covered under this Limited Warranty.

### **C. PARTS MANUFACTURED BY OTHERS**

This Limited Warranty does not cover any parts manufactured by others. Such parts are subject to the warranty, if any, of their respective manufacturers, and are to be repaired only by a respective authorized service person for such parts. The Manufacturer shall have no obligation to undertake repairs of parts manufactured by others.

### **D. NO SPECIAL, INCIDENTAL, OR CONSEQUENTIAL DAMAGES**

**IN NO EVENT SHALL THE MANUFACTURER BE LIABLE TO THE BUYER OR ANY OTHER PERSON FOR ANY INDIRECT, SPECIAL, INCIDENTAL OR CONSEQUENTIAL LOSSES OR DAMAGES CONNECTED WITH THE USE OF THE PRODUCT UNDER THIS LIMITED WARRANTY. SUCH DAMAGES FOR WHICH THE MANUFACTURER SHALL NOT BE RESPONSIBLE INCLUDE, BUT ARE NOT LIMITED TO, LOST TIME AND CONVENIENCE, LOSS OF USE OF THE PRODUCT, THE COST OF A PRODUCT RENTAL, COSTS OF GASOLINE, TELEPHONE, TRAVEL, OR LODGING, THE LOSS OF PERSONAL OR COMMERCIAL PROPERTY, AND THE LOSS OF REVENUE.**

### **E. NO LIABILITY IN EXCESS OF PURCHASE PRICE**

**IN NO EVENT SHALL THE MANUFACTURER’S OBLIGATIONS UNDER THIS LIMITED WARRANTY EXCEED THE PURCHASE PRICE OF THE PRODUCT.**

### **F. NO EXTENSION OF STATUTE OF LIMITATIONS**

**ANY REPAIRS PERFORMED UNDER THIS WARRANTY SHALL NOT IN ANY WAY EXTEND THE STATUTES OF LIMITATIONS FOR CLAIMS UNDER THIS LIMITED WARRANTY.**

### **G. WAIVER OF OTHER WARRANTIES**

**THE EXPRESS WARRANTIES SET FORTH IN THIS LIMITED WARRANTY ARE IN LIEU OF AND EXCLUDE ANY AND ALL OTHER WARRANTIES, EXPRESS OR IMPLIED, INCLUDING, BUT NOT LIMITED TO, THE IMPLIED WARRANTIES OR MERCHANTABILITY AND FITNESS FOR A PARTICULAR PURPOSE.**

## **H. PROCEDURE FOR WARRANTY PERFORMANCE**

If the product fails to perform to the Manufacturer's specifications, the Buyer must provide the Manufacturer with the applicable model and serial numbers, the date of purchase, and the nature of the problem.

### **I. ADDITIONAL EXCLUSIONS FROM THIS LIMITED WARRANTY. THIS LIMITED WARRANTY DOES NOT COVER ANY OF THE FOLLOWING:**

1. Equipment which has been abused, damaged, used beyond rated capacity, or repaired by persons other than authorized service personnel.
2. Damage caused by acts of God which include, but are not limited to, hailstorms, windstorms, tornadoes, sandstorms, lightning, floods, and earthquakes.
3. Damage under conditions caused by fire or accident, by abuse or by negligence of the user or any other person other than the Manufacturer, by improper installation, by misuse, by incorrect operation, by "normal wear and tear", by improper adjustment or alteration, by alterations not completed by authorized service personnel, or by failure of product parts from such alterations.
4. Costs of repairing damage caused by poor or improper maintenance, costs of normally scheduled maintenance, or the cost of replacing any parts unless done as the result of an authorized repair covered by the one (1) year Limited Warranty.
5. Costs of modifying the product in any way once delivered to the Buyer, even if such modifications were added as a production change on other products made after the Buyer's product was built.

### **J. NO AUTHORITY TO ALTER THIS LIMITED WARRANTY**

No agent, representative, or distributor of the Manufacturer has any authority to alter the terms of this Limited Warranty in any way.