



ROCK DRILL INSTRUCTIONS

REIMANN & GEORGER CORPORATION
CONSTRUCTION PRODUCTS
P/N 6122125

BUFFALO, NY
08/29/05

TABLE OF CONTENTS

| CHAPTER | DESCRIPTION | PAGE |
|----------|---|-----------|
| 1 | SAFETY | 1 |
| 1.1 | Introduction | 1 |
| 1.2 | Safety Definitions | 1 |
| 1.3 | Rock Drill Safety Rules | 1 |
| 2 | SPECIFICATIONS | 3 |
| 2.1 | Introduction | 3 |
| 2.2 | Technical Data | 3 |
| 2.3 | Recommended Hydraulic Oil | 3 |
| 2.4 | Nameplate and Serial Number Tag | 4 |
| 3 | OPERATION | 5 |
| 3.1 | Before Operating The Breaker | 5 |
| 3.2 | Low Ambient And Oil Temperature Startup (<32°F) | 5 |
| 3.3 | High Ambient And Oil Temperature Startup (>100°F) | 5 |
| 3.4 | Connection to Hydraulic Power Source | 6 |
| 3.5 | Drilling Procedure | 6 |
| 3.6 | Preparing Breaker For Shutdown | 7 |
| 3.7 | Optional Weight Block | 7 |
| 3.8 | Air Flushing | 7 |
| 4 | INSPECTION AND MAINTENANCE | 8 |
| 4.1 | General Maintenance Rules | 8 |
| 4.2 | Daily Maintenance | 8 |
| 4.3 | Annual Maintenance | 9 |
| 4.4 | Long-Term Storage | 9 |
| 5 | TROUBLESHOOTING | 10 |
| 6 | PARTS LISTS | 11 |
| 6.1 | Impact Assembly | 11 |
| 6.2 | Valve Housing Assembly | 14 |
| 6.3 | Motor Gear Assembly | 14 |
| 6.4 | Accumulator | 15 |
| 6.5 | Cylinder Assembly | 16 |
| 6.6 | Hose Assembly | 17 |
| 6.7 | Ergonomic Handle Assembly | 18 |
| 6.8 | Connecting Block Assembly | 19 |

LIST OF FIGURES

| FIGURE | DESCRIPTION | PAGE |
|--------|----------------------------------|------|
| 2-1 | Typical Product Nameplate | 4 |
| 6-1 | Rock Drill Impact Assembly | 12 |
| 6-2 | Valve Housing Assembly | 13 |
| 6-3 | Motor Gear Assembly | 14 |
| 6-4 | Accumulator Assembly | 15 |
| 6-5 | Cylinder Assembly | 16 |
| 6-6 | Hose Assembly | 17 |
| 6-7 | Handle Assembly | 18 |
| 6-8 | Connecting Block Assembly | 20 |

1 SAFETY

1.1 INTRODUCTION

Your Reimann & Georger Corporation Rock Drill has been engineered to provide breaking performance, long term economics and safety advantages that no other type can match. However, even well-designed and well-built equipment can malfunction or become hazardous in the hands of an inexperienced and/or untrained user. Therefore, read this manual and related equipment manuals thoroughly before operating your Rock Drill to provide maximum safety for all operating personnel, and to get the maximum benefit from your equipment.

1.2 SAFETY DEFINITIONS

A safety message alerts you to potential hazards, which could injure you or others or cause property damage. The safety messages or signal words for product safety signs are **DANGER**, **WARNING**, and **CAUTION**. Each safety message is preceded by a safety alert symbol and is defined as follows:

DANGER: Indicates an imminently hazardous situation which, if not avoided, **will** cause death or serious injury. This safety message is limited to the most extreme situations.

WARNING: Indicates a potentially hazardous situation which, if not avoided, **could** result in death or serious injury.

CAUTION: Indicates a potentially hazardous situation which, if not avoided, **may** result in minor or moderate injury. It may also be used to alert against unsafe practices that may result in property-damage-only accidents.

1.3 ROCK DRILL SAFETY RULES

1. Only trained personnel shall operate the Rock Drill or do repairs. A trained person is one who has read and thoroughly understands this instruction manual and related equipment manuals and, through training and experience, has shown knowledge regarding the safe operational procedures.
2. Construction area is to be kept clear of unauthorized personnel at all times. Place barricades or secure the area in such a manner that no personnel would be injured by flying debris.
3. A hard hat **must** be worn by operator and all bystanders to prevent head injuries.
4. Extra **caution** should be used whenever drilling upwards or horizontally to be aware of falling debris and to prevent slipping or falling down.
5. Never use the Rock Drill in an explosive atmosphere and/or near combustible material that could be ignited by a spark.
6. Provide adequate ventilation or approved NIOSH or MSHA respirators in closed areas to avoid breathing dust during drilling.
7. The outside surface of the Rock Drill can be more than 30°C (86°F) warmer than the air temperature. Always wear protective clothing including gloves.
8. Keep clothing and all parts of the body away from moving parts of this Rock Drill when connected to a hydraulic power source or when being used.
9. Safety goggles **must** be worn by operator and all bystanders to prevent injury to eyes.
10. Safety shoes **must** provide good footing to prevent slipping or falling down.
11. Hearing protection **must** be worn by operator and all bystanders to prevent permanent hearing damage.
12. Avoid “free blows.” Free blows result when the tool is operating, but is not contacting the material being drilled.

13. Use only properly sized tool steels for which the Rock Drill was designed.
14. Do not lean against the Rock Drill to prevent losing foothold. The tool steel could accidentally break or suddenly penetrate the material.
15. Never operate the Rock Drill under the influence of drugs, alcohol, or medication.
16. Do not use the Rock Drill when you are tired or fatigued.
17. Do not use a Rock Drill that shows any signs of damage.
18. Keep the handles dry, clean, and free of oil or fuel.
19. Always hold the Rock Drill with both hands during operation.
20. Do NOT attempt to adjust the Rock Drill during operation.
21. Always shut off the hydraulic power source before disconnecting the hoses, or servicing the Rock Drill.
22. Always shut off the hydraulic power source when not using the equipment.

2 SPECIFICATIONS

2.1 INTRODUCTION

Your Reimann & Georger Corporation Hydraulic Rock Drill is designed for drilling blast holes and test drillings etc. in granite and concretes. A built in torque limiter ensures that the operator can always hold the Rock Drill, if the drill bit gets stuck. As with most hydraulic tools, the hydraulic system requirements detailed in the following section must be met but not exceeded to support tool performance and longevity of equipment.

2.2 TECHNICAL DATA

| | ENGLISH | METRIC |
|--|--------------------------------|----------------------|
| Weight with hose whips and without tool steel | 57 lbs. | (26 kg.) |
| Overall Size | 17-7/8 x 23-5/8 in. | (455 x 600 mm) |
| Oil flow | 5.3 – 6.6 gpm | (20-25 lpm) |
| Oil pressure range | 1450-2000 psi | (100-140 bar) |
| Maximum back pressure in return line | 215 psi | (15 bar) |
| Steel size (hex) | 7/8 X 4- 1/4 in. | (22 X 108 mm) |
| Drill diameter | 63/64 – 1-31/32 in. | (25 - 50 mm) |
| Hollow drill (ISO series 11-17) | | |
| Maximum drill depth without compressed air | 20 in. | (500 mm) |
| Maximum hollow drill depth (depending on material) | 19.7ft. | (6 m) |
| Air flow requirements for drilling | | |
| Air flow | 14 - 42 cfm | (0.4 – 1.2 cmm) |
| Pressure | 72 – 145 psi | (5 – 10 bar) |
| Torque | 48 lbft. | (65 Nm) |
| Revolutions (clockwise) | 320-400 rpm | |
| Accumulator charge pressure (nitrogen) | 580 psi | (40 bar) |
| Required cooling capacity | 7500 BTU/hr. | (2.2 kw) |
| Energy per impact | 24-28 ft.-lb. | (32-38 joules) |
| Blow frequency (blows/minute) | 2400 @ 5.3 gpm, 3000 @ 6.6 gpm | (40-50 Hz) |
| Sound level (decibels) | | 98 dB |
| Couplings | | 1/2" HTMA flush face |

2.3 RECOMMENDED HYDRAULIC OIL

| | | |
|-----------------|----------------------|---------------------|
| Viscosity | 100-200 SUS at 100°F | (20-40 cSt at 40°C) |
| Viscosity index | | Minimum 100 |

Many types of compatible hydraulic oil are available through your local dealer/distributor. As an original equipment manufacturer, RGC supplies a Grade ISO VG 32 hydraulic oil.

Hydraulic oil types are too numerous to list in this manual. If you have any question concerning the type of oil suitable for rock drill operation, please consult your local supplier or Reimann & Georger Corporation for details.

2.4 NAMEPLATE AND SERIAL NUMBER TAG

It is important to identify your Rock Drill completely and accurately whenever ordering spare parts or requesting assistance in service. The Rock Drill has a product nameplate that states the model and serial numbers. The Rock Drill label should appear as the sample nameplate shown in Figure 2-1. Record the model and serial numbers for future reference.

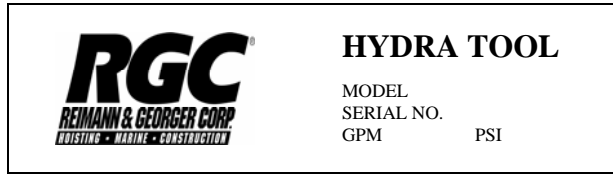

Figure 2-1.
Typical Product Nameplate

MODEL _____ **ROCK DRILL** _____

SERIAL NUMBER _____

3 OPERATION

3.1 BEFORE OPERATING THE ROCK DRILL



CAUTION:

THE HYDRAULIC ROCK DRILL CANNOT RECEIVE A REVERSE OIL FLOW WITHOUT SUSTAINING SOME FORM OF DAMAGE. USE OF A POWER SOURCE OTHER THAN AN RGC POWER UNIT REQUIRES THAT THE MANUAL FOR THAT POWER SOURCE BE CHECKED FOR PRESSURE AND TANK CONNECTIONS TO INSURE PROPER OIL FLOW DIRECTION. ROCK DRILL WARRANTY MAY BE IN JEOPARDY IF CAUTION IS NOT EXERCISED PRIOR TO CONNECTION OF TOOL.

1. Read and fully understand the operating manual for the hydraulic power source being used.
2. Every tool has a maximum operating flow and pressure, which, if exceeded, is a potential cause of damage to the tool or hydraulic power source. Check the power supply's flow and pressure output against the tool's requirements.
3. Use caution when refueling a gasoline driven hydraulic power source. Make sure the gas caps on the hydraulic power source and fuel can are properly tightened. Move the hydraulic power source at least 10 feet from the fueling point before starting the engine.
4. Do not start drilling without first checking for live electrical wiring or utility/supply piping near the drill site, or imbedded in the material to be drilled.

3.2 LOW AMBIENT AND OIL TEMPERATURE STARTUP (<32°F)

Oil temperatures can affect both power supply and tool performance. For ambient operating temperatures between 0-32°F, RGC recommends a warm-up period relative to outside temperatures to insure proper performance levels.

Oil becomes more viscous or thick as the ambient temperature lowers, which slows down the system. It is necessary to pre-heat the hydraulic oil in the power supply before use by proceeding as follows:

1. Leave the equipment inside a heated facility before use if practical, but this is not always possible.
2. At the job site, start the power supply and let the engine warm up for 5 minutes WITHOUT tool or hoses connected.
3. Adjust throttle speed to full engine rpm, then SLOWLY turn flow valve to ON position. Allow unit to run for 5-7 minutes, then turn flow valve to OFF position. Return engine RPM to slow idle; then turn off engine. Connect tool and hydraulic hoses as described in section 3.4. This procedure will labor the engine and generate the required heat in the power supply oil.
4. Taking the time to pre-heat the oil far exceeds the length of time it takes to get the system up to speed without pre-heating, but this will provide the level of designed performance.

3.3 HIGH AMBIENT AND OIL TEMPERATURE STARTUP (>100°F)

Oil becomes less viscous or thinner as ambient temperature increases which causes the hydraulic oil to operate at an elevated temperature. For ambient operating temperatures above 100°F (38°C), RGC recommends the following:

1. Insure that the hydraulic fluid level is up in the power supply reservoir.
2. Operate the tool at a reduced cycle time—10 minutes on, then 10 minutes off.

3.4 CONNECTION TO HYDRAULIC POWER SOURCE

1. Before making any hydraulic connections, inspect all hoses for leaks and risks of rupture as follows:

- a. Inspect each hose for breaks, cracks, worn spots, bulges, chemical attack, kinks or any other damage. Never stop any detected leak with your hand or fingers. Do not put your face close to suspected leaks. Hold a piece of cardboard close to suspected leaks and then inspect the cardboard for signs of hydraulic oil.
- b. Replace a damaged hose immediately. Never repair the hose.



WARNING:

LIQUID UNDER HIGH PRESSURE CAN PIERCE THE SKIN, CAUSING DEATH OR SERIOUS INJURY. HOT LIQUID CAN CAUSE SERIOUS PERSONAL BURNS. IF AN INJURY OCCURS, GET IMMEDIATE MEDICAL ATTENTION.

2. For connection, use a high pressure hose (inside diameter 1/2") which, as a minimum, is designed for a working pressure of 2500 psi. The breaker socket "P" is the oil inlet (pressure), and the socket "T" is the oil outlet (tank).
3. The Rock Drill uses flush-face quick-release couplings, which are durable and very easy to clean. They are always fitted such that the male part gives oil and the female part receives oil.
4. The Rock Drill is designed for an oil flow of 5.3-6.6 gpm at 1400-2000 psi. Do NOT exceed this flow or pressure.
5. If the oil flow cannot be adjusted by lowering the rpm, a flow divider must be installed. This will insure the Rock Drill receives the correct oil flow and return excess oil back to the tank.
6. To protect the Rock Drill from excessively high pressure, the pressure relief valve of the hydraulic power source must be set at 2000 psi (140 bar). If this is not possible, installing a separate pressure relief valve set at 2000 psi (140 bar) can be used to make the connection. If in doubt, contact your dealer.
7. The backpressure (return line pressure) of the Rock Drill should be as low as possible and must not exceed 215 psi (15 bar) measured at the Rock Drill. If this pressure is exceeded, the Rock Drill will not rotate.
8. The hydraulic power source must be fitted with a return line oil filter with a filter rating of 10 microns.

3.5 DRILLING PROCEDURE

1. Check that the drill bit is intact and sharp and that the drill bit is pressed fully home in the nose part.
2. Clean the quick-release couplings if needed and connect the hose whips to the extension hoses from the power source.
3. When lifting the Rock Drill to start the procedure, observe the following precautions:
 - a. Be sure of your footing.
 - b. Keep hands off trigger to avoid accidental operation.
 - c. Bend your knees and lift with your legs.
 - d. Hold Rock Drill close to your body when lifting.
5. Place the Rock Drill vertically on the surface in which the hole is to be made and activate the trigger lever. Make sure just enough feed force is being applied to have the Rock Drill run regularly. Activating the trigger partially when starting provides a slow start for improved control.
6. If different length drills are required to drill the same hole, the bits **MUST** be from the same ISO- series. Failure to do this can cause binding of the bit resulting in tool and / or drill bit damage and personal injury. Use just enough feed force to have the Rock Drill run regularly.



CAUTION:

AVOID “FREE BLOWS” (THE PISTON HITTING THE UNSUPPORTED DRILL), AS THIS WILL LEAD TO UNNECESSARY HEATING OF THE OIL AND IN THE LONG RUN DAMAGE BOTH SEALS AND ROCK DRILL.

7. When drilling without air flushing (use of compressed air), a hollow drill bit with an open air hole **MUST NOT** be used, as this will cause excessive dust accumulation around the piston causing accelerated wear of the piston and seals.

3.6 PREPARING ROCK DRILL FOR SHUTDOWN

1. Stop the Rock Drill by releasing the trigger lever.
2. Stop the hydraulic power source following the procedure in the respective instruction manual.
3. Disconnect the hoses from the Rock Drill.



WARNING:

NEVER DISCONNECT ANY HYDRAULICALLY OPERATED PART OF THE ROCK DRILL OR REMOVE HYDRAULIC COMPONENTS, LINES, OR FITTINGS WHILE THE POWER SOURCE IS RUNNING OR WHENEVER THE HYDRAULIC FLUID IS HOT.

LIQUID UNDER HIGH PRESSURE CAN PIERCE THE SKIN, CAUSING DEATH OR SERIOUS INJURY. HOT LIQUID CAN CAUSE SERIOUS PERSONAL BURNS. IF AN INJURY OCCURS, GET IMMEDIATE MEDICAL ATTENTION.

4. Secure the Rock Drill and hydraulic power source to prevent unauthorized use.
5. Store the Rock Drill away from excessive heat or moisture. Store in a clean, dry area away from exposure to high humidity, liquids, or freezing temperatures.

3.7 OPTIONAL WEIGHT BLOCK

The Rock Drill is provided with threaded holes for mounting a weight block or supporting root. When using a weight block of 25-33 lbs. as additional weight, it is not necessary for the operator to apply any additional feed force. This is particularly advantageous if the job takes a long time.

3.8 AIR FLUSHING

When air flushing is required, the Rock Drill can be connected to any air compressor with a minimum 14 cfm at 70psi output. If the holes to be drilled are not deep, and the drilling dust is dry, a small compressor capacity will often be sufficient, whereas the drilling of deeper holes with moist dust will require a higher compressor in order to achieve sufficient air flushing.

Connection can be made by means of standard air components and hose with a minimum rating of 145psi (10bar). The hose diameter should not be less than 1/2” ID in order to prevent pressure loss.

4 INSPECTION AND MAINTENANCE

4.1 GENERAL MAINTENANCE RULES

Hydraulic fluid can become contaminated after extended periods of use which can cause restrictions in the system. Check to see that the fluid is clean, and change at recommended intervals to extend tool's life. Refer to the respective manual for maintenance information on the hydraulic power source.

1. Proper maintenance of the Rock Drill and related equipment requires timely adhering to all the guidelines given in this chapter. Proper maintenance is required to maintain the system in good condition and free of defects.
2. Review and follow all the safety rules given in Chapter 1 before attempting any maintenance.
3. Only authorized personnel should be allowed in the maintenance area. Authorized personnel are the trained people as defined below and their supervision.
4. Repairs must be made only by trained personnel. A trained person is one who has read and thoroughly understands this instruction manual and related equipment manuals and, through training and experience, has shown knowledge regarding the safe operational procedures.



CAUTION:
BEFORE STARTING ANY MAINTENANCE, DISCONNECT FROM HYDRAULIC POWER SOURCE TO PREVENT ACCIDENTAL STARTUP.



WARNING:
DURING ANY MAINTENANCE OR REPAIR PROCEDURES, DO NOT ATTEMPT ANY DRILLING. THIS CAN CAUSE SERIOUS PERSONAL INJURY AND/OR EQUIPMENT DAMAGE.

4.2 DAILY MAINTENANCE

1. Wipe couplings clean and connect hydraulic hoses to an unpowered (not activated) hydraulic source.
2. Remove the tool steel. With a clean object, push the piston through the bushing to its inner most position. Remove the object and using the grease nipple located in the nose assembly, lubricate the bushing with Molykote grease, like Molykote 81 or similar. Failure to grease the nose assembly every 8 hours of operation will cause the drive system to stop rotating.
3. Clean off any accumulation of particles from beneath the trigger area. Spray with a light oil and wipe off excess.
4. Disconnect hydraulic hoses and wipe couplings clean, especially before a connection is made. This is the single most common point of entry for foreign particles which can cause premature wear of hydraulic components in the system.
5. Check that all hardware on the Rock Drill is tight.
6. Check the hoses before each use for damage. Replace a damaged hose immediately. Never repair the hose.
7. Before each use, insure that all broken, worn or defective parts are repaired or replaced.
8. Insure the tool steel is sharp to give maximum drilling power and operator comfort.

4.3 ANNUAL MAINTENANCE

1. Check that the drill bushing, latch, and roll pins are in good working order. If the shaft of a new drill can be turned more than 20° in the drill bushing, or if the drill collar is cracked, the drill bushing must be replaced. A worn drill bushing causes increased breaker noise and, in the long run, damage to the striking piston of the Rock Drill.
2. Check the function and performance of the Rock Drill.
3. It is recommended that the Rock Drill be serviced at an authorized RGC service center where:
 - a. the accumulator is inspected and recharged.
 - b. moving parts, drill bushing, and bolts for example, are inspected and, if required, replaced.
 - c. all seals are replaced.

4.4 LONG-TERM STORAGE

During long-term storage, the striking piston must be protected against corrosion. Connect the quick-release couplings together and press the striking piston to its upper position with a clean object placed down through the drill bushing.

5 TROUBLESHOOTING

The following chart is intended to assist with troubleshooting the Hydraulic Rock Drill. While not all inclusive, the chart outlines the most common causes of a problem and the recommended course of action.

The troubleshooting guide for the associated power supply is in the instruction manual specifically for this unit.

| SYMPTOM | CAUSE AND CORRECTIVE ACTION |
|--|---|
| Rock Drill does not rotate—pressure does not build up when trigger is activated. | <p>No or incorrect flow or pressure—check flow and pressure as described in Section 3.4.</p> <p>“P” and “T” hoses interchanged—check connection. Standard connection has oil flowing from male quick release coupling into female quick release coupling. The tail-hose of the Rock Drill P connection is fitted with female coupling.</p> <p>Insufficient activation of trigger valve—replace defective parts.</p> |
| Rock Drill does not rotate—pressure is built up when trigger is activated. | <p>Back pressure too high—make direct tank connection. Maximum back pressure is 215 psi (15 bar) measured at the Rock Drill. See Section 3.4.</p> <p>Quick release coupling in return line defect—locate and replace defective coupling.</p> <p>Striking piston sticks—push the breaker hard against the drill.</p> <p>Grease nose assembly as described in Section 4.2.</p> <p>Striking piston sticks possibly due to thickening of cylinder:</p> <ol style="list-style-type: none"> 1. Chamfer/polish slightly the edge at the cylinder dashpot where the cylinder bore changes size. 2. Check oil viscosity. Thin oil increases the risk of cylinder thickening. <p>Spool/reversing spool or auxiliary spools stick—dismount and check that all parts move easily. Polish slightly if necessary.</p> <p>Seals defect—dismount, check, and replace.</p> |
| Drill runs weakly or erratically. | <p>Insufficient flow—check flow and pressure.</p> <p>Seals defect—replace seals.</p> <p>Wear, internal leakage:</p> <ol style="list-style-type: none"> 1. Dismantle, check and replace defective or worn parts. 2. Check purity of oil and oil viscosity at working temperature. Thin oil can cause increased internal leakage. <p>Incorrect tool steel length—refer to Section 2.2.</p> |
| Hoses pulsate. | Accumulator defect—replace accumulator diaphragm and charge with nitrogen. |
| Oil leaking from drill. | Defective seals—replace seals. |
| Drill falls out. | <p>Worn latch—replace latch and roll pins.</p> <p>Worn drill bushing or drill—replace bushing or drill.</p> <p>Incorrect tool steel in use (wrong hex size or collar diameter)—refer to Section 2.2.</p> |

6 PARTS LISTS

The following parts lists apply to the Rock Drill only. The parts list for the hydraulic power source is in the separate manual supplied for this item. Each item number on the following parts lists can be matched with the item number shown on the corresponding assembly drawings as described in the following sections.

6.1 IMPACT ASSEMBLY

Refer to Figure 6-1.

| Item Number | Part Number | Quantity | Description |
|-------------|-------------|----------|---------------------------|
| 1 | 1817054 | 1 | CHISEL RETAINER COMPLETE |
| 2 | 1817177 | 1 | GEAR FLANGE |
| 3 | 1817150 | 1 | BUSHING W/ COGGING |
| 4 | 1817104 | 1 | STRIKING PISTON |
| 5 | 1817174 | 2 | FLANGE SOCKET |
| 6 | 1817175 | 2 | PIPE HOLDER |
| 7 | 1817107 | 1 | DRAIN PIPE |
| 8 | 1817108 | 1 | TIGHTENING PLATE |
| 9 | 1817109 | 2 | STAY BOLT LONG |
| 10 | 1817110 | 2 | STAY BOLT SHORT |
| 11 | 1817145 | 1 | WASHER F/SPRING |
| 12 | 1817146 | 1 | SPRING F/ CHISEL RETAINER |
| 13 | 1817147 | 1 | COUPLING NUT F/ SPRING |
| 14 | 1817141 | 1 | THRUST WASHER |
| 15 | 1817700 | 1 | O-RING |
| 16 | 1817720 | 4 | SCREW |
| 17 | 1817727 | 1 | SCREW |
| 18 | 1817755 | 2 | O-RING |
| 19 | 1817701 | 2 | O-RING |
| 20 | 1817002 | 1 | O-RING |
| 21 | 7000477 | 2 | SCREW |
| 22 | 1817765 | 1 | SCREW |
| 23 | 1817756 | 2 | BACK-UP RING |
| 24 | 1817724 | 1 | SCREW |
| 25 | 1817757 | 1 | O-RING |
| 26 | 1817739 | 1 | CYLINDER PIN |
| 27 | 1816708 | 1 | GREASE NIPPLE |
| 28 | 1817704 | 1 | O-RING |
| 29 | 1817718 | 4 | WASHER |
| 30 | 1817714 | 4 | NUT |
| 31 | 7016375 | 2 | SEAL RING |
| 32 | 1817725 | 2 | SCREW |
| 36 | 1805714 | 2 | SEAL RING |
| 38 | 1814750 | 2 | O-RING |
| 39 | 1814751 | 1 | O-RING |
| 40 | 1817179 | 1 | INA-RING IR |
| 41 | 1817763 | 2 | INA-RING IR |
| 42 | 1814749 | 1 | O-RING |
| 43 | 1815135 | 2 | ADAPTOR |
| | 1817035 | 1 | SEAL KIT |

We recommend the oscillator upper and lower sleeves and spool is replaced as a set to ensure optimum performance.

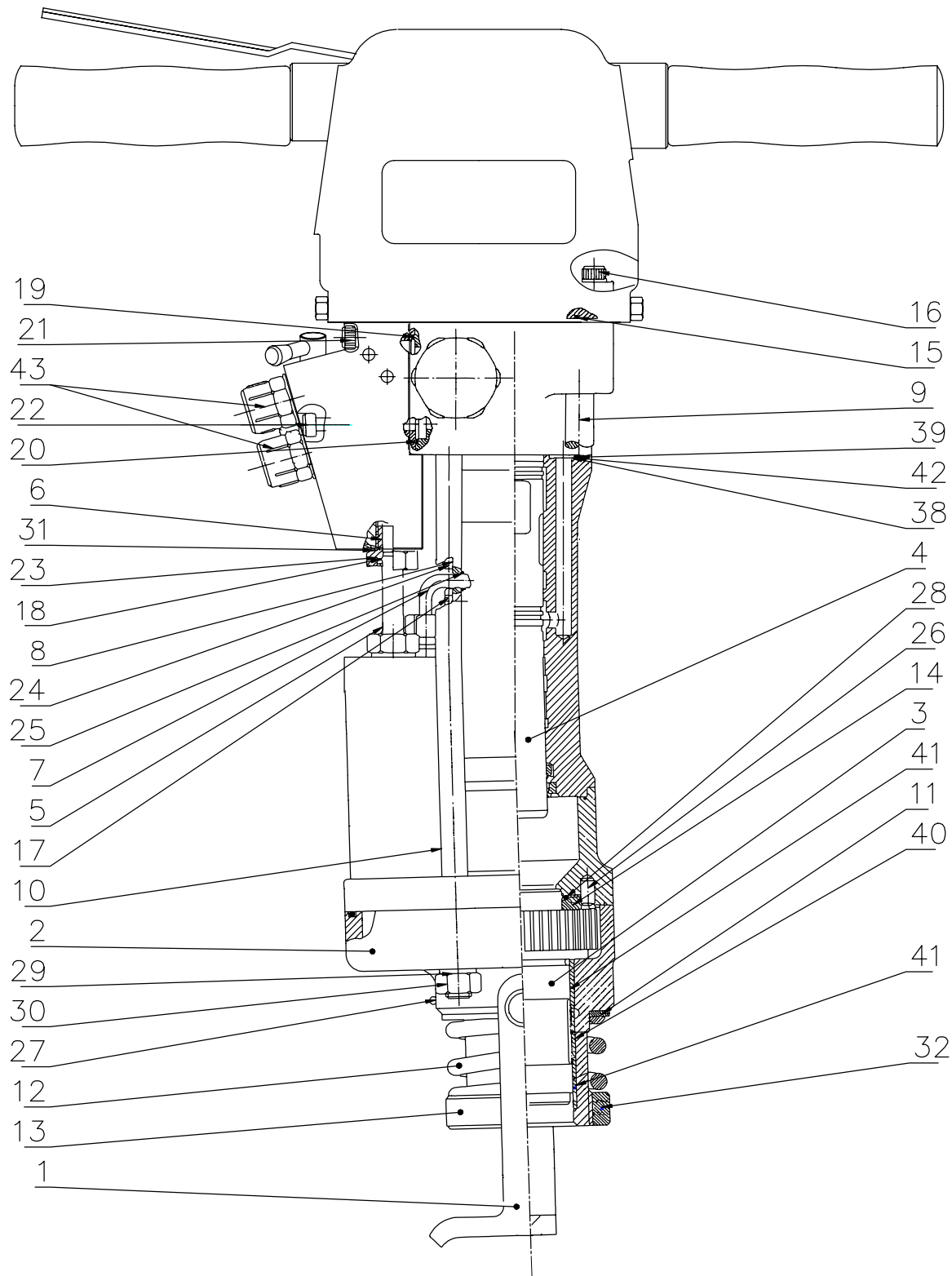

Figure 6-1.
Rock Drill Impact Assembly

6.2 VALVE HOUSING ASSEMBLY

Refer to Figure 6-2.

| Item Number | Part Number | Quantity | Description |
|-------------|-------------|----------|----------------------|
| 45 | 1817115 | 1 | VALVE HOUSING |
| 46 | 1814114 | 1 | GUIDE SOCKET P |
| 47 | 1814113 | 1 | AUXILIARY SPOOL P |
| 48 | 1814116 | 1 | GUIDE SOCKET T |
| 49 | 1814115 | 1 | AUXILIARY SPOOL T |
| 50 | 1814112 | 1 | SPOOL |
| 51 | 1817154 | 1 | SEALING WASHER |
| 52 | 1817155 | 1 | SCREW F/ CHECK VALVE |
| 53 | 1814703 | 2 | O-RING |
| 54 | 1814710 | 2 | O-RING |
| 55 | 1814736 | 1 | BLIND NUT |
| 56 | 1817705 | 1 | O-RING |
| 57 | 1817712 | 1 | SEAL RING |
| 58 | 1817748 | 1 | STEEL BALL |
| 59 | 1817741 | 1 | ROLL PIN |

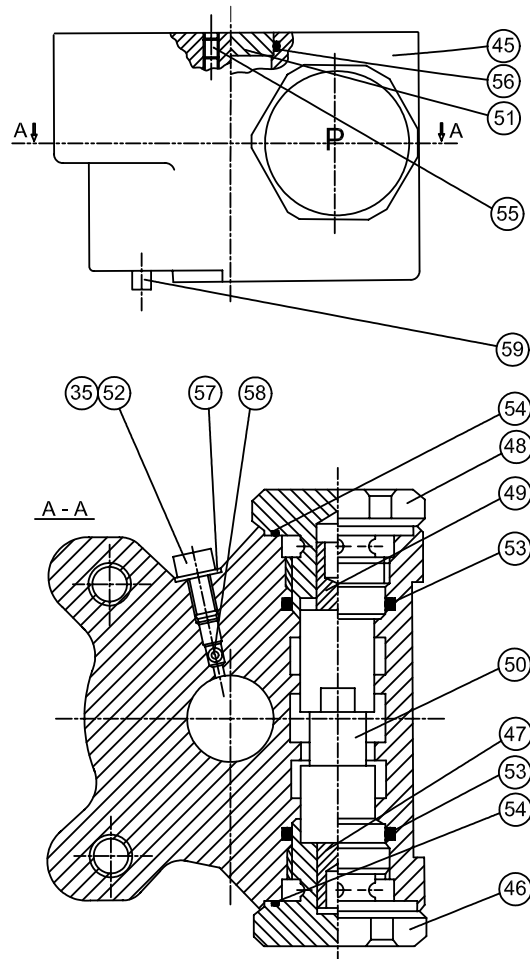

Figure 6-2.
Valve Housing Assembly

6.3 MOTOR GEAR ASSEMBLY

Refer to Figure 6-3.

| Item Number | Part Number | Quantity | Description |
|-------------|-------------|----------|----------------|
| 65 | 1817133 | 1 | MOTOR FLANGE |
| 66 | 1817135 | 1 | GEAR WHEEL |
| 67 | 1817136 | 1 | BACK-UP WASHER |
| 68 | 1817148 | 1 | PACKING GLAND |
| 69 | 1817149 | 1 | COUPLING NUT |
| 70 | 1817757 | 1 | O-RING |
| 71 | 1817746 | 1 | MOTOR |
| | 1817750 | 1 | MOTOR SEAL KIT |
| 72 | 1817726 | 3 | SCREW |
| 73 | 1817764 | 1 | SCREW |

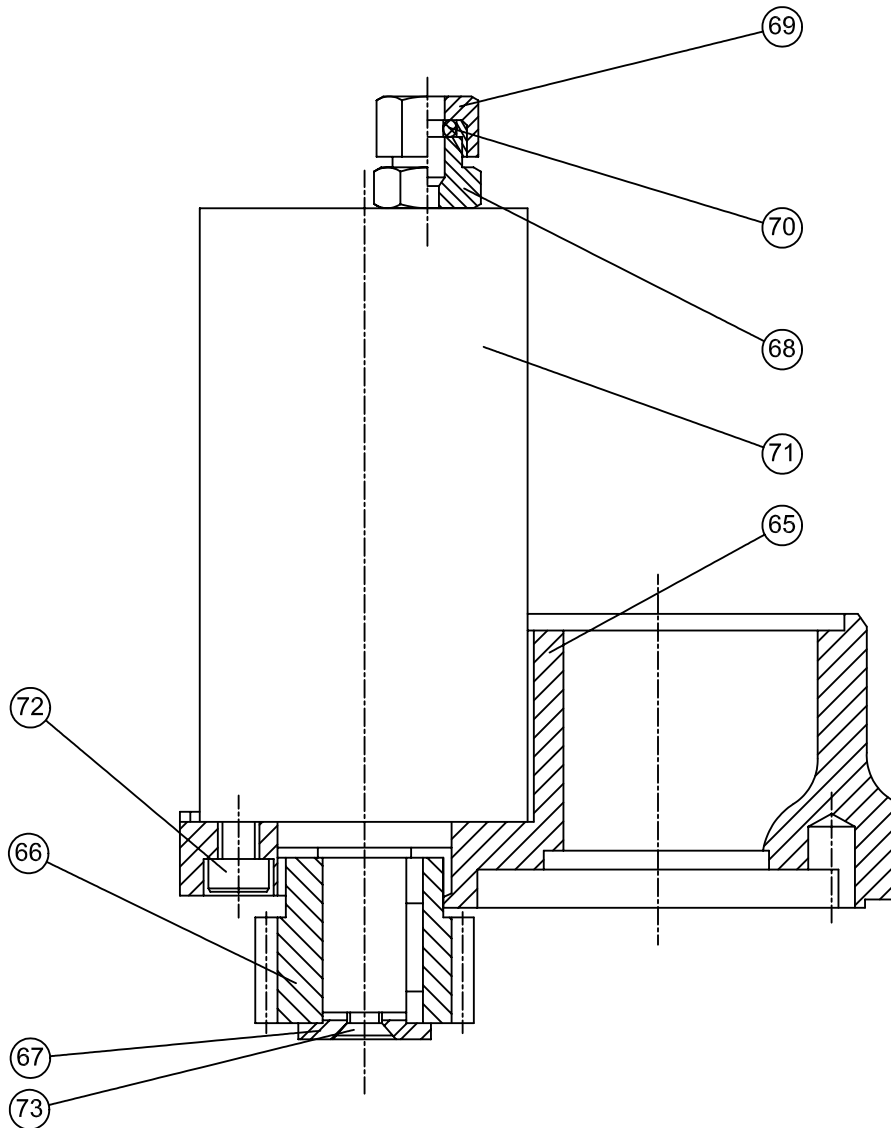

Figure 6-3.
Motor Gear Assembly

6.4 ACCUMULATOR

Refer to Figure 6-4.

| Item Number | Part Number | Quantity | Description |
|-------------|-------------|----------|-------------------|
| 75 | 1814052 | 1 | DIAPHRAGM |
| 76 | 1814102 | 1 | ACCUMULATOR COVER |
| 77 | 1817111 | 1 | ACCUMULATOR BODY |
| 78 | 1813103 | 1 | CHARGING SCREW |
| 79 | 1814709 | 1 | SEAL RING |
| 80 | 1813710 | 1 | PROTECTIVE CAP |

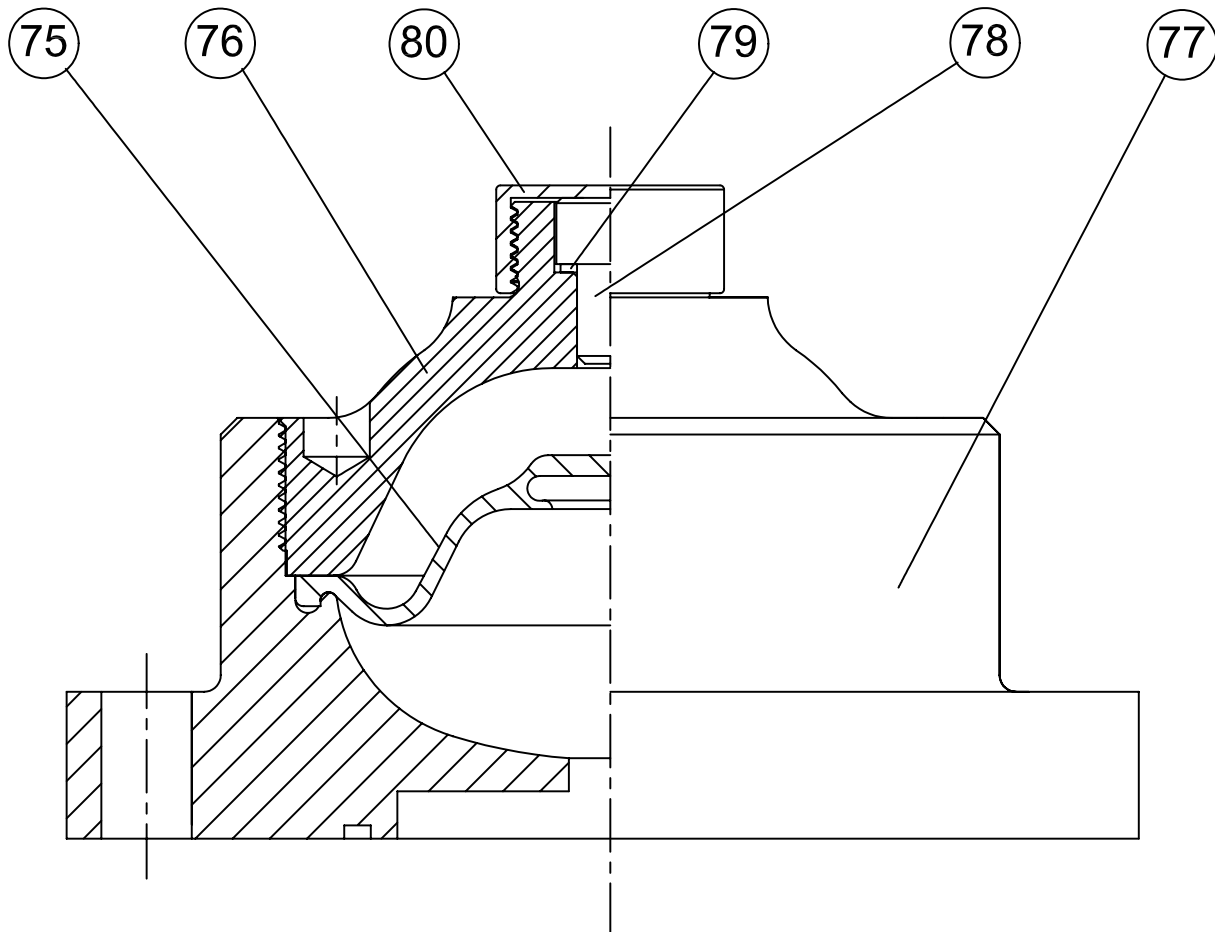

Figure 6-4.
Accumulator Assembly

6.5 CYLINDER ASSEMBLY

Refer to Figure 6-5.

| Item Number | Part Number | Quantity | Description |
|-------------|-------------|----------|------------------|
| 85 | 1817102 | 1 | CYLINDER HOUSING |
| 86 | 1814172 | 1 | SEAL |
| 87 | 1814707 | 1 | SEAL |
| 88 | 1814733 | 3 | FITTING |
| 89 | 1814754 | 1 | LOCKING RING |
| 90 | 1814169 | 1 | BACK-UP WASHER |

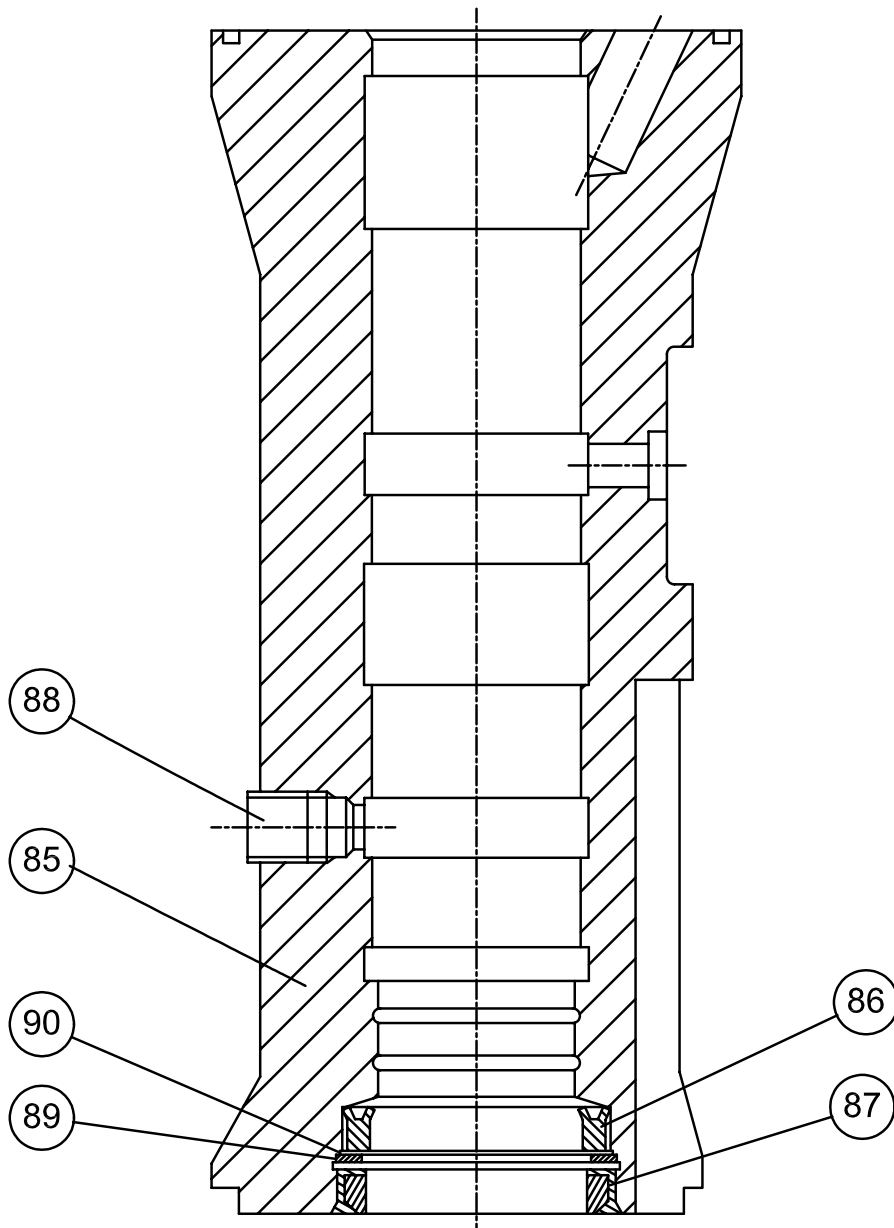

Figure 6-5.
Cylinder Assembly

6.6 HOSE ASSEMBLY

Refer to Figure 6-6.

| Item Number | Part Number | Quantity | Description |
|-------------|-------------|----------|----------------------|
| 95 | 1697502 | 2 | HOSE WHIPS 12" |
| 96 | 6001886 | 1 | COUPLING 1/2" FEMALE |
| 97 | 6001885 | 1 | COUPLING 1/2" MALE |

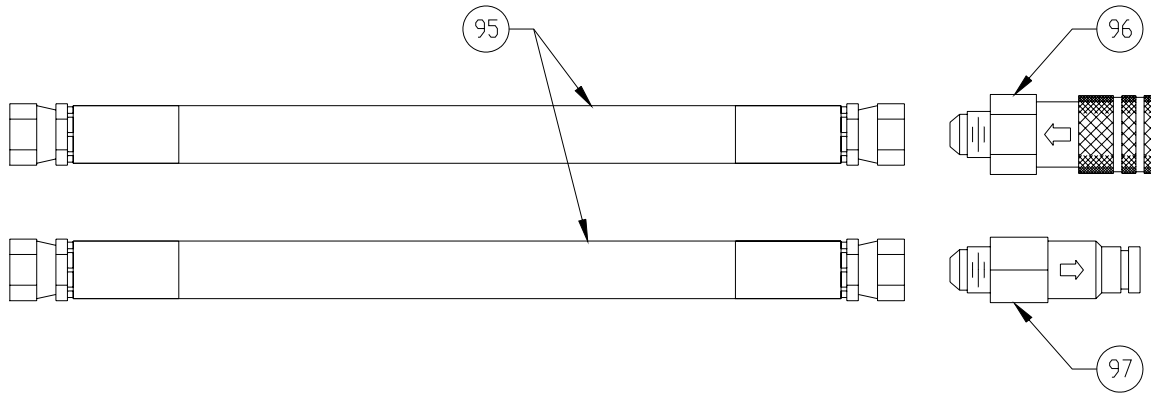

Figure 6-6.
Hose Assembly

6.7 HANDLE ASSEMBLY

Refer to Figure 6-7.

| Item Number | Part Number | Quantity | Description |
|-------------|-------------|----------|----------------------------|
| 100 | 1820203 | 1 | BRACKET F/ STANDARD HANDLE |
| 101 | 1820204 | 2 | HANDLE STANDARD |
| 102 | 1820135 | 1 | RUBBER HANDLE TRIGGER SIDE |
| 103 | 1820134 | 1 | RUBBER HANDLE |
| 104 | 1820238 | 1 | TRIGGER LEVER STANDARD |
| 106 | 1815733 | 1 | ROLL PIN |
| 107 | 1820041 | 1 | TOP COVER |
| 108 | 1815722 | 4 | SCREW |
| 109 | 1815131 | 2 | NAB |
| 110 | 1815113 | 4 | SPACER F/ HANDLE |
| 111 | 1817189 | 1 | NYLON GUIDE |
| 112 | 1803044 | 1 | LABEL |
| 115 | 1820741 | 1 | SLOTTED PIN |
| 116 | 1820236 | 1 | SAFETY TRIGGER |
| 117 | 1820747 | 2 | NYLON WASHER |
| 118 | 1820237 | 1 | LOCK PLATE |
| 119 | 1820152 | 1 | SPRING |

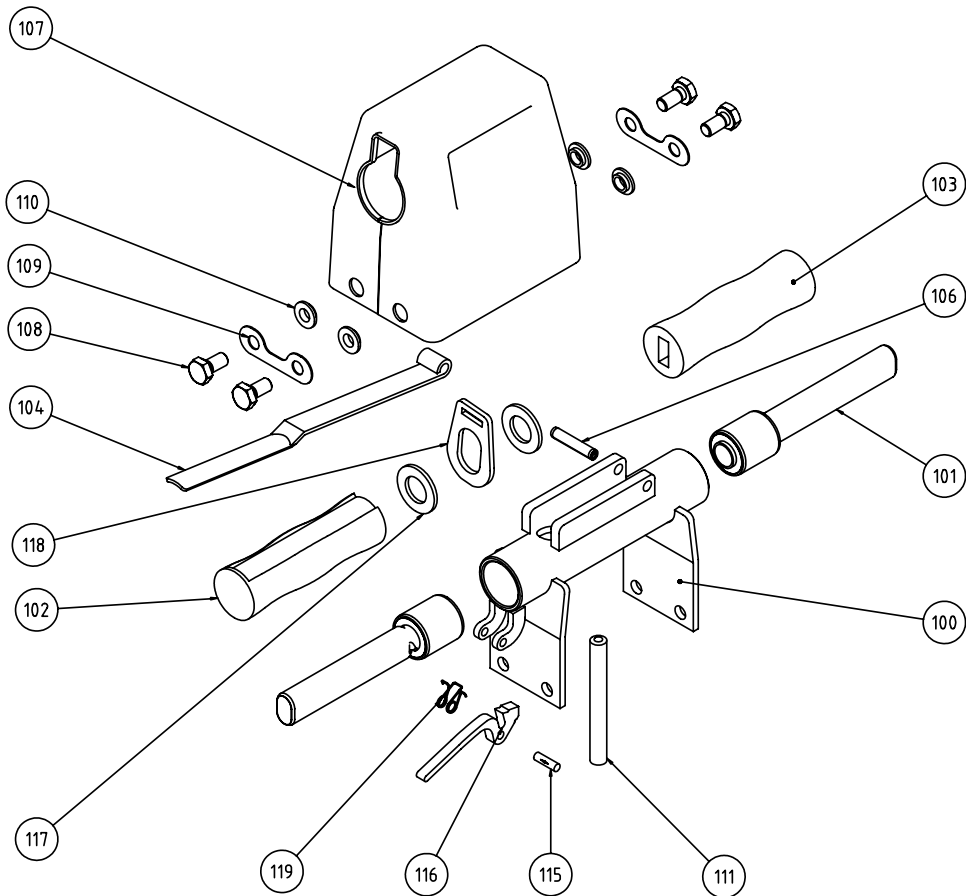

Figure 6-7.
Handle Assembly

6.8 CONNECTING BLOCK ASSEMBLY

Refer to Figure 6-8.

| Item Number | Part Number | Quantity | Description |
|-------------|-------------|----------|--------------------------|
| 120 | 1817186 | 1 | PLATE F/ TRIGGER |
| 121 | 1817187 | 1 | SPACE PIPE F/ TRIGGER |
| 122 | 7121508 | 2 | SCREW |
| 123 | 1814161 | 1 | TRIGGER SPOOL |
| 124 | 1815166 | 1 | TRIGGER ROD |
| 125 | 1814120 | 1 | PACKING GLAND |
| 126 | 1814163 | 1 | SPRING F/ TRIGGER VALVE |
| 127 | 1814700 | 1 | O-RING |
| 128 | 1814702 | 1 | O-RING |
| 129 | 1805503 | 1 | SEAL |
| 130 | 1814701 | 1 | BACK-UP RING |
| 131 | 1814712 | 1 | SEEGER SPRING RING |
| 132 | 1814732 | 2 | SEEGER SPRING RING |
| 133 | 1817740 | 1 | FITTING W/ SEAL |
| 134 | 1817130 | 1 | TORQUE LIMITER |
| 135 | 1817131 | 1 | SPRING F/ TORQUE LIMITER |
| 136 | 7016125 | 1 | SEAL RING |
| 137 | 1817185 | 1 | AIR VALVE |
| 138 | 6100008 | 1 | O-RING |
| 139 | 1817728 | 1 | SCREW |
| 140 | 1817767 | 1 | ROLL PIN |
| 141 | 1817766 | 1 | BLACK TIP |
| 142 | 1817188 | 1 | CONNECTING BLOCK |
| 143 | 1814733 | 3 | FITTING |
| 144 | 1817742 | 1 | PLASTIC PLUG |

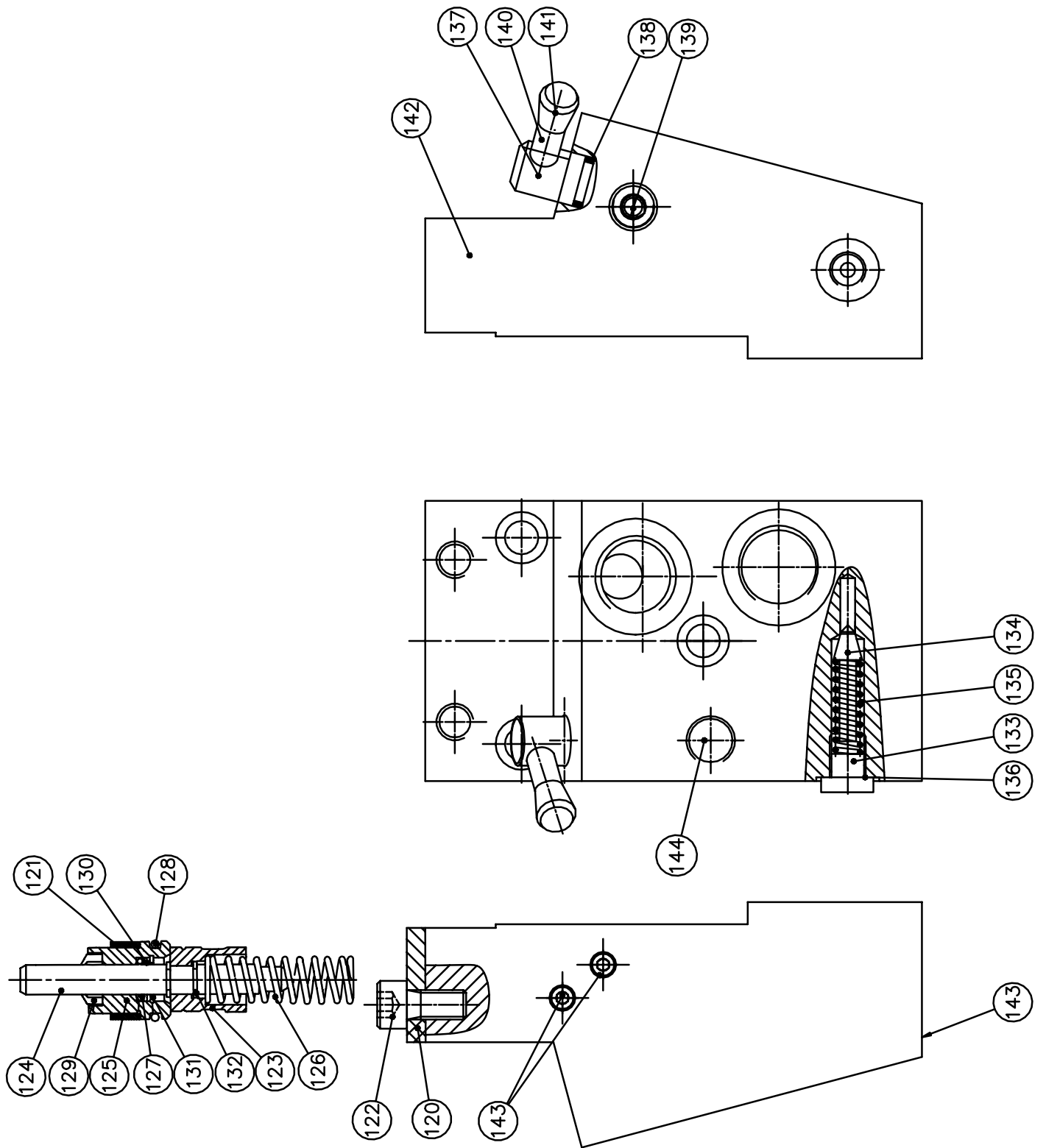

Figure 6-8.
Connecting Block

LIMITED PRODUCT WARRANTY

**Reimann & Georger Corporation
Hoisting and Construction Products**

A. LIMITED WARRANTY

Reimann & Georger Corporation (the "Manufacturer") warrants to the original purchaser (the "Buyer") that all Reimann & Georger Hoisting and Construction products shall be free of defects in material and workmanship for a period of one (1) year from date of original purchase.

B. MANUFACTURER'S OBLIGATIONS

The Manufacturer's sole obligation under this Limited Warranty is the repair or, at the Manufacturer's discretion, the replacement of parts found to be defective. Parts and equipment must have authorization from the Manufacturer prior to return to the Manufacturer or repair by an authorized service person. Costs of transportation and other expenses connected with replacing or repairing parts are not covered under this Limited Warranty.

C. PARTS MANUFACTURED BY OTHERS

This Limited Warranty does not cover any parts manufactured by others. Such parts are subject to the warranty, if any, of their respective manufacturers, and are to be repaired only by a respective authorized service person for such parts. The Manufacturer shall have no obligation to undertake repairs of parts manufactured by others.

D. NO SPECIAL, INCIDENTAL, OR CONSEQUENTIAL DAMAGES

IN NO EVENT SHALL THE MANUFACTURER BE LIABLE TO THE BUYER OR ANY OTHER PERSON FOR ANY INDIRECT, SPECIAL, INCIDENTAL OR CONSEQUENTIAL LOSSES OR DAMAGES CONNECTED WITH THE USE OF THE PRODUCT UNDER THIS LIMITED WARRANTY. SUCH DAMAGES FOR WHICH THE MANUFACTURER SHALL NOT BE RESPONSIBLE INCLUDE, BUT ARE NOT LIMITED TO, LOST TIME AND CONVENIENCE, LOSS OF USE OF THE PRODUCT, THE COST OF A PRODUCT RENTAL, COSTS OF GASOLINE, TELEPHONE, TRAVEL, OR LODGING, THE LOSS OF PERSONAL OR COMMERCIAL PROPERTY, AND THE LOSS OF REVENUE.

E. NO LIABILITY IN EXCESS OF PURCHASE PRICE

IN NO EVENT SHALL THE MANUFACTURER'S OBLIGATIONS UNDER THIS LIMITED WARRANTY EXCEED THE PURCHASE PRICE OF THE PRODUCT.

F. NO EXTENSION OF STATUTE OF LIMITATIONS

ANY REPAIRS PERFORMED UNDER THIS WARRANTY SHALL NOT IN ANY WAY EXTEND THE STATUTES OF LIMITATIONS FOR CLAIMS UNDER THIS LIMITED WARRANTY.

G. WAIVER OF OTHER WARRANTIES

THE EXPRESS WARRANTIES SET FORTH IN THIS LIMITED WARRANTY ARE IN LIEU OF AND EXCLUDE ANY AND ALL OTHER WARRANTIES, EXPRESS OR IMPLIED, INCLUDING, BUT NOT LIMITED TO, THE IMPLIED WARRANTIES OR MERCHANTABILITY AND FITNESS FOR A PARTICULAR PURPOSE.

H. PROCEDURE FOR WARRANTY PERFORMANCE

If the product fails to perform to the Manufacturer's specifications, the Buyer must provide the Manufacturer with the applicable model and serial numbers, the date of purchase, and the nature of the problem.

I. ADDITIONAL EXCLUSIONS FROM THIS LIMITED WARRANTY. THIS LIMITED WARRANTY DOES NOT COVER ANY OF THE FOLLOWING:

1. Equipment which has been abused, damaged, used beyond rated capacity, or repaired by persons other than authorized service personnel.
2. Damage caused by acts of God which include, but are not limited to, hailstorms, windstorms, tornadoes, sandstorms, lightning, floods, and earthquakes.
3. Damage under conditions caused by fire or accident, by abuse or by negligence of the user or any other person other than the Manufacturer, by improper installation, by misuse, by incorrect operation, by "normal wear and tear", by improper adjustment or alteration, by alterations not completed by authorized service personnel, or by failure of product parts from such alterations.
4. Costs of repairing damage caused by poor or improper maintenance, costs of normally scheduled maintenance, or the cost of replacing any parts unless done as the result of an authorized repair covered by the one (1) year Limited Warranty.
5. Costs of modifying the product in any way once delivered to the Buyer, even if such modifications were added as a production change on other products made after the Buyer's product was built.

J. NO AUTHORITY TO ALTER THIS LIMITED WARRANTY

No agent, representative, or distributor of the Manufacturer has any authority to alter the terms of this Limited Warranty in any way.