



HH500 & HV500 HYDRAULIC POWER DRIVE INSTRUCTIONS

REIMANN & GEORGER CORPORATION
HOISTING PRODUCTS
P/N 6102024

BUFFALO, NY
08/08/11

PRE-OPERATIVE CHECKLIST

This checklist must be checked prior to each use of the power drive. This checklist is to be used as a guideline in conjunction with the maintenance and inspection procedures outlined in this manual. The power drive and related equipment must be thoroughly inspected prior to each use by a trained person. A trained person is one who has read and thoroughly understands this instruction manual and related equipment manuals and, through training and experience, has shown knowledge regarding the safe operational procedures. If you do not have such a person in your organization, please contact Reimann & Georger Corporation or its distributors and they will assist you in providing such a "trained person." Do not permit any person who is not fully trained to operate this power drive or the associated hoist. It is recommended that this checklist be maintained as a permanent record.

- Ensure a competent person has determined the structural deck can support the intended loads in hoisting and material handling.
- Ensure hoisting operation will clear all power lines and obstructions.
- Ensure that no hoisting will be done over an open doorway.
- Discuss work plan, personal protective equipment, and each crewmember's responsibility before starting to set-up.
- Ensure OSHA compliant fall protection is in place.
- Ensure hoisting area is secured from all unauthorized personnel.
- Ensure all structural members of the hoist and power drive are free of defects and damage that may affect their integrity.
- Ensure sheaves can rotate freely.
- Ensure bolt securing wire rope end loop to the drum flange is tight and in good condition.
- Inspect wire rope for signs of wear and damage. Replace defective wire rope immediately.
- If using a TT1000 hoist mounted power drive, ensure wire rope is reeved for single part of line for 500 lbs. capacity or two (2) parts of line for 1000 lbs. capacity.
- If using a ground mounted power drive, ensure wire rope is reeved ONLY for single part of line for 500 lbs. capacity.
- For a TT1000 hoist mounted power drive, ensure 1500 lbs. (680 kg.) of Reimann & Georger Corporation approved ballast blocks are secured in the rear leg base with rope.
- For a ground mounted power drive, ensure 1500 lbs. (680 kg.) of Reimann & Georger Corporation approved ballast blocks are secured with rope in the rear leg base of the TT1000 hoist and 1500 lbs. of ballast are secured on the ground mount brackets.
- Ensure that the load will not exceed the 500 lb. or 1000 lb. limit for, respectively, one or two parts of line reeving.
- Ensure that at least three wraps of wire rope are on the winch drum at maximum travel.
- Ensure there is sufficient weight on the wire rope to maintain 10-20 lbs. of tension at all times.
- Ensure power drive has been properly maintained.
- Operate hoist and power drive with no load to test hoisting operation and power drive controls.

INSPECTOR: _____ DATE: _____

TABLE OF CONTENTS

CHAPTER	TITLE	PAGE
1	SAFETY	1
1.1	Introduction	1
1.2	Safety Definitions	1
1.3	Power Drive and Hoist Safety Labels.....	1
1.4	Power Drive Safety Rules	1
2	SPECIFICATIONS	3
2.1	Technical Data.....	3
2.2	Recommended Hydraulic Oil	3
2.3	Nameplate and Serial Number Tag.....	4
3	INSTALLATION AND SETUP	5
3.1	Prior to Installation	5
3.2	Ballast Block Assembly.....	5
3.3	Mounting Power Drive onto Hoist	6
3.4	Mounting Power Drive on the Ground	7
4	OPERATION.....	8
4.1	Safety Pre-Start Checks	8
4.2	Engine Pre-Start Checks	8
4.3	Hydraulic System Pre-Start Checks.....	9
4.4	Operating the Controls	9
4.5	Preparing Power Drive for Shutdown	10
5	INSPECTION AND MAINTENANCE	11
5.1	General Maintenance Rules.....	11
5.2	Initial Inspection	11
5.3	Daily Inspection.....	11
5.4	Engine Maintenance	12
5.5	Wire Rope Inspection Procedure.....	13
6	TROUBLESHOOTING	14
7	PARTS LIST	16
7.1	HH500 & HV500 Hoist Mount	16
7.2	HH500 & HV500 Ground Mount	18

LIST OF FIGURES

FIGURE	DESCRIPTION	PAGE
2-1	Typical Power Drive Product Nameplate	4
3-1	Ballast Block Assembly.....	6
3-2	Ballast Block Filling.....	6
5-1	Wire Rope Components	13
7-1	Hoist Mount Assembly	17
7-2	Ground Mount Assembly	19

1 SAFETY

1.1 INTRODUCTION

Your Reimann & Georger Corporation HH500 or HV500 power drive has been engineered to provide lifting performance, long term economics and safety advantages that no other type can match. However, even a well-designed and well-built power drive can malfunction or become hazardous in the hands of an inexperienced and/or untrained user. Therefore, read this manual and related equipment manuals thoroughly before operating your power drive to provide maximum safety for all operating personnel, and to get the maximum benefit from your equipment.



WARNING:

WHEN THIS POWER DRIVE IS USED IN CONJUNCTION WITH THE TT1000 TROLLEY HOIST, DO NOT USE THE POWER DRIVE WITHOUT STUDYING BOTH THIS MANUAL AND THE TT1000 MANUAL

1.2 SAFETY DEFINITIONS

A safety message alerts you to potential hazards which could injure you or others or cause property damage. The safety messages or signal words for product safety signs are **DANGER**, **WARNING**, and **CAUTION**. Each safety message is preceded by a safety alert symbol and is defined as follows:

DANGER: Indicates an imminently hazardous situation which, if not avoided, **will** cause death or serious injury. This safety message is limited to the most extreme situations.

WARNING: Indicates potentially hazardous situation which, if not avoided, **could** result in death or serious injury.

CAUTION: Indicates a potentially hazardous situation which, if not avoided, **may** result in minor or moderate injury. It may also be used to alert against unsafe practices and property-damage-only accidents.

1.3 POWER DRIVE AND HOIST SAFETY LABELS

These labels warn you of potential hazards which could cause injury. Read them carefully. If a label comes off or becomes illegible, contact Reimann & Georger Corporation for a free replacement.

1.4 POWER DRIVE SAFETY RULES

1. Operators must be thoroughly trained before operating the power drive. A trained person is one who has read and thoroughly understands this instruction manual and related equipment manuals and, through training and experience, has shown knowledge regarding the safe operational procedures.
2. Prior to operating the power drive there must be a plan of action outlining the work to be accomplished, individual responsibilities, personal protective equipment, and method of communication.
3. A good line of communication must be maintained between the power drive operator and the rest of the crew. All crewmembers must be familiar with hand signals.
4. Hoisting area is to be kept clear of unauthorized personnel at all times. Place barricades or secure the area in such a manner that if there were an equipment failure, no personnel would be injured.
5. All personnel shall be protected by OSHA compliant fall protection.
6. Hoisting area is to be clear of power lines. Consult power company before you work near power lines.
7. Follow the Pre-Operative Checklist before using the equipment.
8. Do not use the power drive if it shows any signs of damage.

9. Never use the power drive in an explosive atmosphere and/or near combustible material that could be ignited by a spark.
10. Inspect the wire rope for wear and damage prior to each use. Replace defective wire rope immediately.
11. Wear heavy leather gloves when handling wire rope. Insufficient hand protection when handling wire rope can cause personal injury.
12. When mounting the power drive on the hoist, ensure 1500 lbs. (680kg.) of ballast blocks are secured properly in the rear leg base of the hoist. In a ground mounted application, ensure 1500 lbs. (680 kg.) of ballast blocks are secured properly in the rear leg base of the hoist and 1500 lbs. (454 kg.) of ballast are secured properly on the ground mounted power drive before doing any hoisting.
13. Use only Reimann & Georger Corporation concrete filled ballast blocks or factory approved equal as counterweight for the hoist frame. A ground mounted power drive must use acceptable ballast material. **No** human being shall **ever** be used as ballast.
14. Never exceed the Rated Load Capacity of 1000 lbs. when the power drive is mounted on the hoist and reeved with two parts of line, or 500 lbs. when the power drive is ground mounted. The Rated Load Capacity is the maximum load that should ever be applied to the hoist. Rated Load Capacity is for straight line pull; avoid side loads.
15. Avoid sudden stops and shock loads.
16. Check the power drive periodically during operation. Know how to stop the power drive quickly in case of emergency.
17. Do not try to adjust the power drive while it is being operated.
18. Keep all body parts clear of moving parts.
19. Always shut off the power drive before performing any maintenance or when not using the equipment. Never remove fittings or components when hydraulic fluid is hot.
20. Allow engine to cool ten minutes before refueling.
21. Use an approved fuel container in a well-ventilated area when refueling. Move fuel container at least ten feet from fueling point before starting.
22. At end of operation, the power drive should be secured to prevent unauthorized use. Never assume you will find the power drive in the same condition in which you left it.
23. Only trained personnel are authorized to do repairs.
24. Do not operate the power drive when under the influence of drugs, alcohol, or medication.

2 SPECIFICATIONS

2.1 TECHNICAL DATA

The following specifications apply to the HH500 and HV500 power drives. Detailed specifications for the TT1000 hoist are in the separate manual for this item.

Hoisting capacity:

With power drive mounted on hoist:	1000 lbs. (454 kg.) with two parts of line 500 lbs. (227 kg.) with single part of line
With power drive ground mounted:	500 lbs. (227 kg.)

Counterweight required:

With power drive mounted on hoist:	1500 lbs. (680 kg.)
With power drive ground mounted:	1500 lbs. (680 kg.) on ground mount brackets and 1500 lbs. (680 kg.) in hoist frame

Ballast block weight (approximate)

50 lbs. (23 kg.)

Ballast blocks required

30 for 1500 lb. counterweight

Wire rope supplied

200 ft. 3/16" wire rope

Maximum wire rope length *

350 ft.

Engine:

8 hp Honda (**HH500**) or 7.5 hp Vanguard (**HV500**)

Mounting Method

Hoist or Ground

Number of Cylinders

1

RPM maximum

3600

Hydraulic System:

Operating Pressure

1500 psi

Reservoir

3 U.S. gallons—shipping cap and vented fill cap provided

Pump Type

Gear type positive displacement

Pumping Capacity

6 GPM @ 3600 rpm

Motor

Geroler type

Valve

Single valve, open center, top of spool stamped 0-4

Filters

Oil type, replacement Parker 921, Fram P165, or AC PF16

Suction Screen

10 mesh

Filler/Breather

100 mesh

* Consult factory for longer wire rope lengths.

2.2 RECOMMENDED HYDRAULIC OIL

Many types of compatible hydraulic oil are available through your local dealer/distributor. As an original equipment manufacturer, RGC uses a Grade ISO VG 32 hydraulic turbine oil.

Hydraulic oil types are too numerous to list in this manual. If you have any question concerning the type of oil suitable for your power drive operation, please consult your local supplier or Reimann & Georger Corporation for details.

2.3 NAMEPLATE AND SERIAL NUMBER TAG

It is important to identify your power drive completely and accurately whenever ordering spare parts or requesting assistance in service. The power drive has a product nameplate that shows the model and serial numbers and capacity rating. The power drive label should appear as the sample nameplate shown in Figure 2-1. Record the model and serial numbers, and capacity rating for future reference.



Figure 2-1.
Typical Power Drive Product Nameplate

MODEL _____

SERIAL NUMBER _____

CAPACITY RATING _____

3 INSTALLATION AND SETUP

3.1 PRIOR TO INSTALLATION

1. Ensure that the hoist frame assembling on the deck has been completed.
2. Ensure that all structural members of the hoist are free of defects and damage that may affect the integrity of the unit.
3. Do not use the power drive if it shows any signs of damage.



WARNING:

ENSURE THE HOISTING AREA IS SECURED FROM ALL UNAUTHORIZED PERSONNEL. ENSURE THAT OSHA COMPLIANT FALL PROTECTION IS IN PLACE.



WARNING:

A COMPETENT PERSON MUST DETERMINE THAT THE STRUCTURAL DECK CAN SUPPORT THE INTENDED LOADS IN HOISTING AND MATERIAL HANDLING IN ADDITION TO THE WEIGHT OF THE COUNTERWEIGHT ON THE ROOF DECK. FAILURE TO DO THIS CAN RESULT IN DEATH, SERIOUS PERSONAL INJURY OR EQUIPMENT FAILURE.



WARNING:

PRIOR TO SETTING UP THE HOIST AND INSTALLING THE POWER UNIT, THERE MUST BE A PLAN OF ACTION OUTLINING THE WORK TO BE ACCOMPLISHED, INDIVIDUAL RESPONSIBILITIES, PERSONAL PROTECTIVE EQUIPMENT, AND THE METHOD OF COMMUNICATION. FAILURE TO DO THIS CAN RESULT IN DEATH, SERIOUS PERSONAL INJURY OR EQUIPMENT FAILURE.



WARNING:

NEVER WORK NEAR A ROOF EDGE WHILE SETTING UP THE POWER UNIT. ANY ACCIDENT NEAR A ROOF EDGE CAN CAUSE DEATH OR SERIOUS PERSONAL INJURY.

4. The correct counterweight must be installed as described in Sections 3.3 and 3.4. Make sure it is properly nested. For equipment protection and safety of personnel, the counterweight ballast blocks for the hoist frame must be prepared properly as described in Section 3.2.
5. If mounting the power drive onto the hoist, refer to Section 3.3. If mounting the power drive on the ground, refer to Section 3.4.

3.2 BALLAST BLOCK ASSEMBLY

Before using the ballast blocks, they must be filled with the proper amount of concrete. Prepare the ballast blocks as follows:

1. Place the ballast block handle in the base section of the ballast weight. (This is the section without the filling hole.) This handle can stand upright by itself. Position top section of ballast block over base section, push down and snap into position. See Figure 3-1.
2. Place a funnel into the opening and pour a loosely mixed, flowing concrete into the box. Funnel may require slitting to fit opening of ballast block. Position ballast block on an angle to ensure complete filling. See Figure 3-2.



WARNING:

TO ACHIEVE THE REQUIRED BALLAST BLOCK WEIGHT OF 50 POUNDS, BE SURE TO FILL BLOCK COMPLETELY. THE WEIGHT OF THE BALLAST BLOCK MAY VARY DUE TO THE CONSISTENCY OF THE CONCRETE MIX. DO NOT USE MORTAR MIX. THIS WILL NOT GIVE THE REQUIRED MINIMUM BALLAST BLOCK WEIGHT OF 50 POUNDS. USE A SCALE TO DETERMINE THE WEIGHT OF THE BALLAST. THIS WILL ENSURE SAFE OPERATION IN ACCORDANCE WITH THESE INSTRUCTIONS. NEVER USE A HUMAN BEING AS BALLAST AS THE EQUIPMENT IS NOT DESIGNED FOR THE SAME AND CAN RESULT IN DEATH OR SERIOUS INJURY.

3. Allow the concrete to set 10 minutes; then remove excess concrete from handle area to allow hand clearance. Wipe off top and base of box to allow nesting into the rear leg base of the hoist.

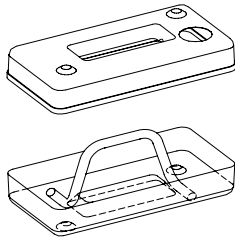

**Figure 3-1.
Ballast Block Assembly**

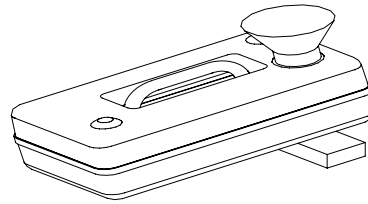

**Figure 3-2.
Ballast Block Filling**

3.3 MOUNTING POWER DRIVE ONTO HOIST

Refer to Chapter 3 of the TT1000 manual for details on the following steps:

1. Ensure that the ballast blocks have been assembled properly and the correct counterweight has been installed on the hoist.



WARNING:

ENSURE 1500 LBS. (680 KG.) OF REIMANN & GEORGER CORPORATION APPROVED BALLAST BLOCKS ARE SECURED PROPERLY IN THE REAR LEG BASE WITH ROPE BEFORE OPERATING THE HOIST. AN INADEQUATE COUNTERWEIGHT CAN CAUSE TOPPLING OF EQUIPMENT, RESULTING IN SERIOUS PERSONAL INJURY OR DEATH.

USE ONLY REIMANN & GEORGER CORPORATION BALLAST BLOCKS FILLED PROPERLY WITH CONCRETE OR FACTORY APPROVED EQUAL AS COUNTERWEIGHT.

2. Raise the power drive to the roof. Have four people lift the power drive and slide the trolley support into the power drive. Pin with the spring lock pin and use the hitch pin to attach the power drive support to the trolley support.
3. Reeve the wire rope for either one or two parts of line. **Never** exceed the rated load capacity of 500 lbs. for single line operation or 1000 lbs. for double line operation.

3.4 MOUNTING POWER DRIVE ON THE GROUND

1. Ensure that the ballast blocks have been assembled properly and that 1500 lbs. (680 kg.) counterweight has been installed on the TT1000 hoist frame on the roof. Secure these in the rear leg base with rope.
2. Bolt the mounting base brackets provided to the power drive frame.
3. Slide planks through the base brackets and load with 1500 lbs. (680 kg.) of ballast.
4. Secure ballast to ground mount brackets with rope.



WARNING:

ENSURE 1500 LBS. (680 KG.) OF REIMANN & GEORGER CORPORATION APPROVED BALLAST BLOCKS ARE INSTALLED ON THE HOIST FRAME AND 1500 LBS. (680 KG.) OF BALLAST ARE INSTALLED ON THE GROUND MOUNT BRACKETS BEFORE OPERATING A GROUND MOUNTED POWER DRIVE. AN INADEQUATE COUNTERWEIGHT CAN CAUSE TOPPLING OF EQUIPMENT, RESULTING IN DEATH OR SERIOUS PERSONAL INJURY.

USE ONLY REIMANN & GEORGER CORPORATION BALLAST BLOCKS FILLED PROPERLY WITH CONCRETE OR FACTORY APPROVED EQUAL AS COUNTERWEIGHT IN THE HOIST FRAME.

5. The ground mounted power drive can only be reeved with one part of line. Unwind enough wire rope from the winch to reeve it through block #13 on the hoist trolley track. Fasten the shackle and safety hook to the wire rope and return it to the ground. The return side of the line should be the side closest to the supporting wall to provide maximum ease and safety during loading and unloading on the roof. **Never** exceed the Rated Load Capacity of 500 lbs. in a ground mounted power drive installation.



WARNING:

NEVER REEVE THE GROUND MOUNTED POWER UNIT WITH TWO PARTS OF LINE.

4 OPERATION

4.1 SAFETY PRE-START CHECKS



WARNING:

ONLY TRAINED PERSONNEL SHALL OPERATE THE POWER DRIVE. A TRAINED PERSON IS ONE WHO HAS READ AND THOROUGHLY UNDERSTANDS THIS INSTRUCTION MANUAL AND RELATED EQUIPMENT MANUALS AND, THROUGH TRAINING AND EXPERIENCE, HAS SHOWN KNOWLEDGE REGARDING THE SAFE OPERATIONAL PROCEDURES.



WARNING:

FOLLOW THE PRE-OPERATIVE CHECKLIST IN THE FRONT OF THIS MANUAL BEFORE USING THE POWER DRIVE.

1. Read the safety labels provided with your power drive. These labels warn you of potential hazards that can cause serious injury. If a label comes off or becomes hard to read, contact Reimann & Georger Corporation for a free replacement.
2. Before starting operation, you should thoroughly read your TT1000 instruction manual for complete safety, operating and maintenance information.
3. Hoisting area is to be kept clear of unauthorized personnel. Place barricades or secure the area in such a manner that if there were an equipment failure, no personnel would be injured.



WARNING:

ENSURE THE CORRECT BALLAST WEIGHT IS SECURED PROPERLY BEFORE OPERATING THE POWER DRIVE AND HOIST. AN INADEQUATE COUNTERWEIGHT CAN CAUSE TOPPLING OF EQUIPMENT, RESULTING IN DEATH OR SERIOUS PERSONAL INJURY.



WARNING:

USE ONLY REIMANN & GEORGER CORPORATION APPROVED BALLAST BLOCKS FILLED PROPERLY WITH CONCRETE OR FACTORY APPROVED EQUAL AS COUNTERWEIGHT IN THE HOIST FRAME. USE ACCEPTABLE BALLAST MATERIAL IN A GROUND MOUNTED POWER DRIVE. THESE MACHINES ARE NOT DESIGNED TO HAVE HUMAN BEINGS USED AS COUNTERWEIGHT. THIS IS AN ABSOLUTE MISUSE OF THE EQUIPMENT, WHICH CAN RESULT IN DEATH OR SERIOUS INJURY.

4. Before applying any load, inspect the wire rope for wear and damage. Replace defective wire rope immediately.

4.2 ENGINE PRE-START CHECKS

1. Check engine oil level. Each unit is pre-tested and filled with oil at the factory. Follow manufacturer's recommendations concerning the type of oil to add if necessary.
2. Check the engine air cleaner and air intake screen for dirt or obstructions. Clean as required.
3. Fill the fuel tank with clean fuel. See the engine manufacturer's specifications for fuel requirements.

**WARNING:**

USE AN APPROVED FUEL CONTAINER IN A WELL VENTILATED AREA WHEN REFUELING. MAKE SURE THE GAS CAPS ON THE POWER DRIVE AND FUEL CAN ARE PROPERLY TIGHTENED. NEVER REMOVE THE FUEL CAP OR ADD FUEL TO A RUNNING OR HOT ENGINE. ENSURE THE FUEL SUPPLY IS AT LEAST 10 FEET FROM THE POWER UNIT BEFORE STARTING THE ENGINE. DO NOT RUN THE ENGINE

4.3 HYDRAULIC SYSTEM PRE-START CHECKS

1. Inspect all hydraulic tubes for leaks and risks of rupture as follows:
 - a. Inspect each tube for cracks, chemical attack, kinks or any other damage. Never stop any detected leak with your hand.
 - b. Replace a damaged tube immediately.

**WARNING:**

LIQUID UNDER HIGH PRESSURE CAN PIERCE THE SKIN, CAUSING SERIOUS INJURY OR DEATH. IN CASE OF INJURY, GET IMMEDIATE MEDICAL ATTENTION.

2. Check hydraulic reservoir as follows.
 - a. Replace the shipping cap with the chrome filler/breather cap provided.
 - b. Fluid level should be 1-1/2" from the top of tank.
 - c. When the oil filter is changed, the suction strainer should be removed and cleaned. The reusable worm gear clamp can be used to replace factory clamps.
 - d. Apply thread sealant to strainer thread and drain plug before reassembly.
3. Extreme weather conditions may require using different viscosity oil or a different fluid in the reservoir from that provided. Consult your local supplier or Reimann & Georger Corporation for details.

4.4 OPERATING THE CONTROLS**WARNING:**

WHEN OPERATING THE POWER DRIVE, OBSERVE ALL SAFETY PRECAUTIONS DESCRIBED IN THE TT1000 MANUAL. FAILURE TO COMPLY COULD RESULT IN DEATH, SERIOUS INJURY AND/OR EQUIPMENT DAMAGE.

1. Put the throttle in the slow position when starting and stopping the engine. This permits a warming and cooling period. Know how to stop your power drive quickly in case of emergency. Consult the engine manual for detailed operation of engine controls.
2. Close the choke to start a cold engine. Open choke slowly after engine starts. The choke must be open during normal operation or when starting a warm engine.
3. Start the engine and allow warming up. To raise a load, increase the engine speed and pull the control lever up. Release the control lever when the load reaches the desired height. The control lever is spring returned to neutral whenever the handle is released.

**WARNING:**

IF ENGINE STALLS ON POWER DRIVE, RELEASE CONTROL LEVER IMMEDIATELY TO PREVENT LOAD FROM FALLING.

4. As additional layers of wire rope are wound onto the drum, the lifting speed increases but the lifting capacity decreases.

**WARNING:**

KEEP OUT FROM UNDER A RAISED LOAD.

5. To lower a load, push the control lever down. Gradually decelerate the lowering speed as it nears the ground.

**CAUTION:**

THE WINCH DRUM MUST ALWAYS HAVE AT LEAST THREE TURNS OF WIRE ROPE WHEN THE LOAD IS AT THE LOWEST POINT OF TRAVEL.

6. Always raise and lower loads smoothly. Avoid sudden starts and stops.
7. Never allow anybody to ride on the hoist. Make a few “dry runs” (without load, but with ballast) to become familiar with operation, controls, and power drive and to test hoisting clearance. Always maintain 10-20 pounds of cable tension with a cable weight. Do NOT attempt to make any equipment adjustments during operation.

4.5 PREPARING POWER DRIVE FOR SHUTDOWN

At the end of operation, secure the equipment to prevent unauthorized use. Never assume you will find the equipment in the same condition that you left it. Proceed as follows:

1. Insert hitch pin #12 through the trolley rail rear hole to prevent the trolley support #10 from rolling forward.
2. Ensure that all lifting tension has been removed from the wire rope.
3. Shut off power drive and take necessary action to prevent its unauthorized use as follows:
 - a. Ensure control lever is in neutral position.
 - b. Move throttle lever to “slow” position.
 - c. Permit the engine and hydraulic system to cool. Run the engine at idle for several minutes if the work load was severe.
 - d. Allow the engine to cool before covering it.

**WARNING:**

NEVER DISCONNECT ANY HYDRAULICALLY OPERATED PART OF THE POWER DRIVE OR REMOVE HYDRAULIC COMPONENTS, LINES, OR FITTINGS WHILE THE POWER DRIVE IS RUNNING OR WHENEVER THE HYDRAULIC FLUID IS HOT.

LIQUID UNDER HIGH PRESSURE CAN PIERCE THE SKIN, CAUSING DEATH OR SERIOUS INJURY. HOT LIQUID CAN CAUSE SERIOUS PERSONAL BURNS. IF AN INJURY OCCURS, GET IMMEDIATE MEDICAL ATTENTION.

4. If the hoist is being permanently disassembled, at the end of a project for example, follow the detailed disassembly procedures in the TT1000 manual.

5 INSPECTION AND MAINTENANCE

5.1 GENERAL MAINTENANCE RULES

Maintenance information for the associated TT1000 hoist is in the separate TT1000 manual.

1. Proper maintenance of the power drive and related equipment consists of adhering to all the guidelines given in this chapter and in the Pre-Operative Checklist in the front of this manual. Proper maintenance is required to maintain the system in good condition, which is defined as each part being free of damage or functional defects.
2. Review and follow all the safety rules given in Chapter 1 before attempting any maintenance.
3. Only authorized personnel should be allowed in the maintenance area. Authorized personnel are the trained people as defined below and their supervision. Place barricades or secure the area in such a manner that if there was an equipment failure, no personnel would be injured.
4. Repairs must be made only by trained personnel. A trained person is one who has read and thoroughly understands this instruction manual and related equipment manuals and, through training and experience, has shown knowledge regarding the safe operational procedures.
5. All authorized maintenance personnel should be wearing, as a minimum, hard hats, safety glasses, and safety shoes.
6. Do not modify the power drive in any way. Such alterations may adversely affect power drive performance and invalidate your warranty.



WARNING:

DURING ANY INSTALLATION, MAINTENANCE, OR REPAIR PROCEDURES, DO NOT ATTEMPT ANY HOISTING.



CAUTION:

EXCEPT FOR MAINTENANCE AND REPAIRS THAT CANNOT BE DONE OTHERWISE, BRING THE LOAD TO ITS LOWEST POSITION WHEN WORKING ON ANY PART OF THE HOIST OR POWER UNIT. SHUT DOWN AND LOCK OUT THE POWER DRIVE TO PREVENT ACCIDENTAL STARTUP. RELIEVE OR RENDER SAFE ALL THE POTENTIALLY HAZARDOUS ENERGY.

7. Hydraulic fluid can become contaminated after extended periods of use, which can cause restrictions in the system. Check to see that the fluid is clean and change at recommended intervals to extend power drive's life.

5.2 INITIAL INSPECTION

Power drive installation and dismantling must be done only by trained personnel. Each time after setting up the power drive and before placing it in service, all parts of it must be thoroughly inspected by trained personnel as described in the remainder of this chapter.

5.3 DAILY INSPECTION

It is important that all the maintenance procedures outlined in the Pre-Operative Checklist in the front of this manual be done daily. Details on inspecting the engine are given in Section 5.4. Details on inspecting the wire rope are given in Section 5.5.

All broken, worn or defective parts must be repaired or replaced before startup.

5.4 ENGINE MAINTENANCE

The engine is guaranteed against defects by its manufacturer. Follow the manufacturer's instructions for proper lubrication and maintenance. The following table summarizes the type and frequency of maintenance required. For repairs, contact the nearest authorized service center.

TYPE OF MAINTENANCE	FREQUENCY OF SERVICE
Check and clean obstruction from air intake screen	Daily
Check engine oil level—add if required	Daily
Check reservoir oil level—add if required	Daily
Wash air filter pre-cleaner	25 hrs.
Change engine oil after first 5 hrs.	50 hrs.
Check air cleaner filter—replace if necessary	100 hrs.
Check and clean obstructions from cooling fins and external surfaces	100 hrs.
Check, clean, and replace spark plug	100 hrs.
Have cylinder head removed and cleaned (leaded fuel)	100 hrs.
Have cylinder head removed and cleaned (unleaded fuel)	200 hrs.
Replace reservoir filter and oil after first 50 hrs.	250 hrs.
Clean suction screen in reservoir	250 hrs.
Check coupling spider	250 hrs.
Grease wheel bearings	500 hrs.
Check ignition timing	500 hrs.
Check valves and tappet clearance	500 hrs.
Check fuel filter in line	500 hrs.
Lightly oil throttle cable	500 hrs.

5.5 WIRE ROPE INSPECTION PROCEDURE

Inspect the wire rope prior to each use and at least daily for signs of wear and damage. Inspect the entire wire rope working length. Thoroughly inspect the rope sections that pass over sheaves or drums, or that make opposing turns. Inspect wire rope and end attachments carefully. While inspecting, examine sheaves, guards, guides, drums, flanges, and other surfaces contacting wire rope during operation. Correct any condition harming the rope in use or other damage or worn surfaces at this time.



WARNING:

WEAR HEAVY LEATHER GLOVES WHEN HANDLING WIRE ROPE. INSUFFICIENT HAND PROTECTION WHEN HANDLING WIRE ROPE CAN CAUSE SERIOUS PERSONAL INJURY.

Remove or replace immediately wire rope with one or more of the following defects:

1. Corrosion
2. Broken wires:
 - (a) One or more valley breaks. A valley break is a wire break occurring in the valley between two adjacent strands.
 - (b) Six randomly distributed broken wires in one rope lay. A rope lay is the length of rope along which one strand makes a complete revolution around the rope. See Figure 5-1. Keeping the rope clean and wound evenly on the drum will increase its life and efficiency.

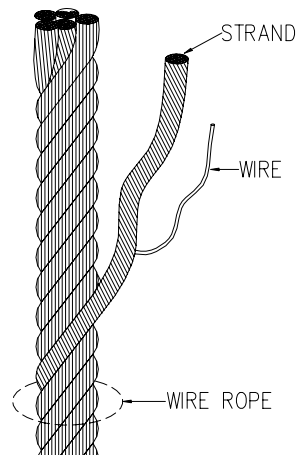

Figure 5-1.
Wire Rope Components

3. Abrasion: Scrubbing, flattening or peening causing loss of more than one-third of the original diameter of the outside wires.
4. Kinking: Severe kinking, crushing, bird caging or other damage causing distortion of the rope structure. Bird caging is a bulging in the wire rope caused by the individual wires becoming untwisted. This untwisting of individual wires is usually caused by impact loading on the wire rope (such as a sudden stop).
5. Heat damage: Evidence of any heat damage caused by a torch or by contact with electrical wires.
6. Reduction of more than 3/64 inch from the nominal 1/4-inch diameter wire rope. Marked reduction in diameter indicates core deterioration.

6 TROUBLESHOOTING

The following chart is intended to assist with troubleshooting the HH500 and HV500 power drives. While not all inclusive, the chart outlines the most common causes of a problem and the recommended course of action.

The troubleshooting guide for the associated TT1000 hoist is in the TT1000 instruction manual.

SYMPTOM	CAUSE AND CORRECTIVE ACTION
<p>Power drive won't lift load—engine operating normally.</p>	<p>Low fluid level in reservoir—fill to required level.</p> <p>Flow restriction caused by:</p> <ol style="list-style-type: none"> a. Kinked or damaged hose b. Pinched or damage steel line c. Poor connection in either a hose or steel line. <p>Coupling between engine and pump damaged—replace the following items as required:</p> <ol style="list-style-type: none"> a. Coupling spider worn out b. Pump or engine key sheared. <p>Pump or motor defective—contact the nearest authorized service center.</p>
<p>Power drive lifting load slowly—engine operating normally.</p>	<p>Engine speed too slow—increase throttling.</p> <p>Load not moving freely—check for block or cable malfunctions on hoist.</p> <p>Too much cable on drum—hoisting capacity decreases as wire rope diameter increases.</p> <p>Power drive attempting to lift more than stated capacity of hoist—check capacity rating and reduce load weight as needed.</p> <p>Low fluid level in reservoir—fill to required level.</p> <p>One or more of the following flow restrictions:</p> <ol style="list-style-type: none"> a. Hose kinked or damaged b. System filter clogged—fluid going through bypass. c. Suction filter clogged—fluid going through bypass. d. Steel line pinched or damaged. <p>Control valve not fully activated.</p> <p>Oil viscosity too heavy for cold climate—contact your local supplier or Reimann & Georger Corporation for information.</p> <p>Pump or motor damaged or worn—contact your nearest authorized service center.</p>
<p>Power drive lifting load slowly—engine operating normally (continued).</p>	<p>System relief valve malfunctioning:</p> <ol style="list-style-type: none"> a. Set too low for application. b. Stuck partially open c. Has broken spring.

System overheats—engine operating normally.	<p>Low fluid level in reservoir—fill to required level.</p> <p>Severe operating conditions caused by extremely high ambient temperature and/or extended duty cycle—operate power drive intermittently to provide cooling periods.</p> <p>Relief valve set too low causing unnecessary bypassing of oil.</p>
Engine frozen.	No oil in crankcase—service at engine manufacturer service center or replace engine with equivalent.
Engine running roughly.	Tune-up or other adjustments required—refer to the engine manufacturer’s instruction manual.
Load drifts or descends when raising control valve.	Cable spooled incorrectly – cable coming off of the top of the drum not the bottom.

7 PARTS LIST

The following parts lists and assembly drawings apply to the HH, & HV500 power drives only. Refer to the TT1000 trolley hoist manual supplied separately for proper use and assembly. Each item number on this parts list can be matched with the number shown in assembly drawing.

7.1 HOIST MOUNT GAS POWER DRIVE

Item Number	Part Number	Quantity	Description
1	0800101	1	FRAME
2	0804840	1	DRUM GUARD
3	0804849	1	WINCH DRUM ASSEMBLY
4	5100925	1	BEARING FLANGE
5	0801435	1	AIR BAFFLE
7	0804091	2	TUBE GUARD
8	0800758	1	LOWER TUBE
9	0800757	1	UPPER TUBE
10	0801440	1	RESERVOIR
11	5800869	4	RUBBER MOUNTS
13	5900918	2	HOSE 3/4" 6 INCH LONG
14	0810962	1	RAM/SINGLE ACTION
15	6900930	1	PUMP 6 GPM
16	6700905	1	PUMP COUPLING 9/16"
17	6700907	1	COUPLING INSERT
19	0804090	1	HOIST SUPPORT ARM
20	6700906	1	MOTOR COUPLING 1"
21	0804844	1	OPERATOR HANDLE KIT
22	5044795	1	HYDRAULIC VALVE WITH HOIST MOUNT HANDLE
23	6000904	1	OIL FILTER
24	6010756	1	MOTOR LOCK VALVE
25	6000759	1	ADAPTER GAUGE PORT
26	0804848	1	GUARD HYDRAULIC MOTOR
27	0804846	1	GUARD SPROCKET
29	6500761	1	HYDRAULIC MOTOR
30	1000981	1	LOCKING ARM ASSEMBLY
31	0804845	1	GUARD-LOCK ARM
32	5800961	1	LOCK ARMSRING
33	0855640	1	ENGINE 7.5 HP VANGUARD (HV500)
33	0855631	1	ENGINE 8 HP HONDA (HH500)
34	6900454	1	PUMP BRACKET
	6901502	1	PUMP BRACKET ACCESS COVER
35	1004155	1	LOCK ARM SPRING STUD
36	6000908	1	SUCTION STRAINER
37	6000921	1	FILTER BREATHER
38	7304212	1	WIRE ROPE ASSEMBLY (200 FEET)
40	5800138	1	ROUND SPRING LOCK PIN
42	0504746	1	HOIST VALVE HANDLE

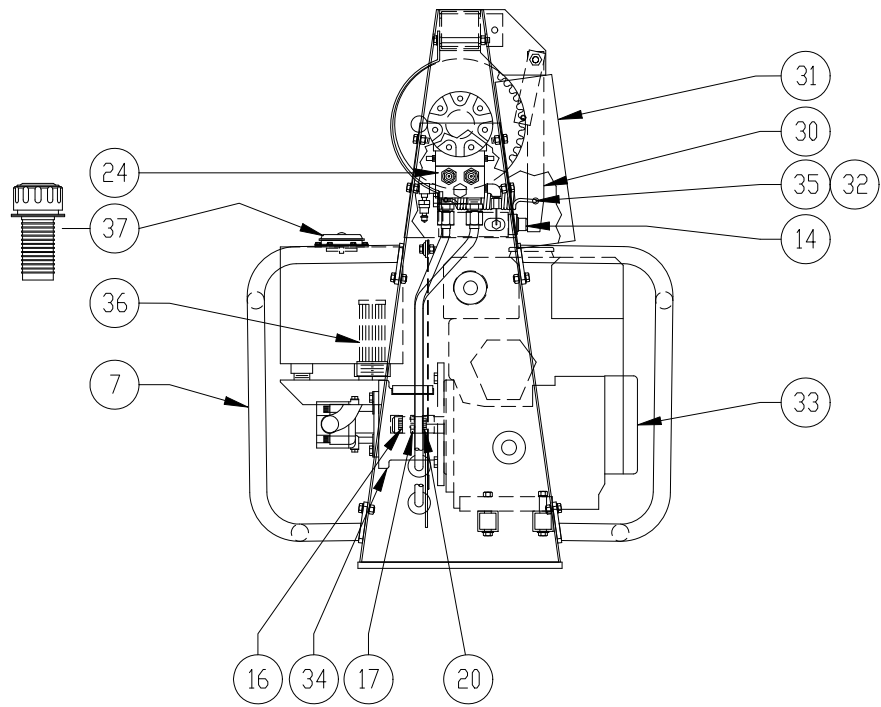
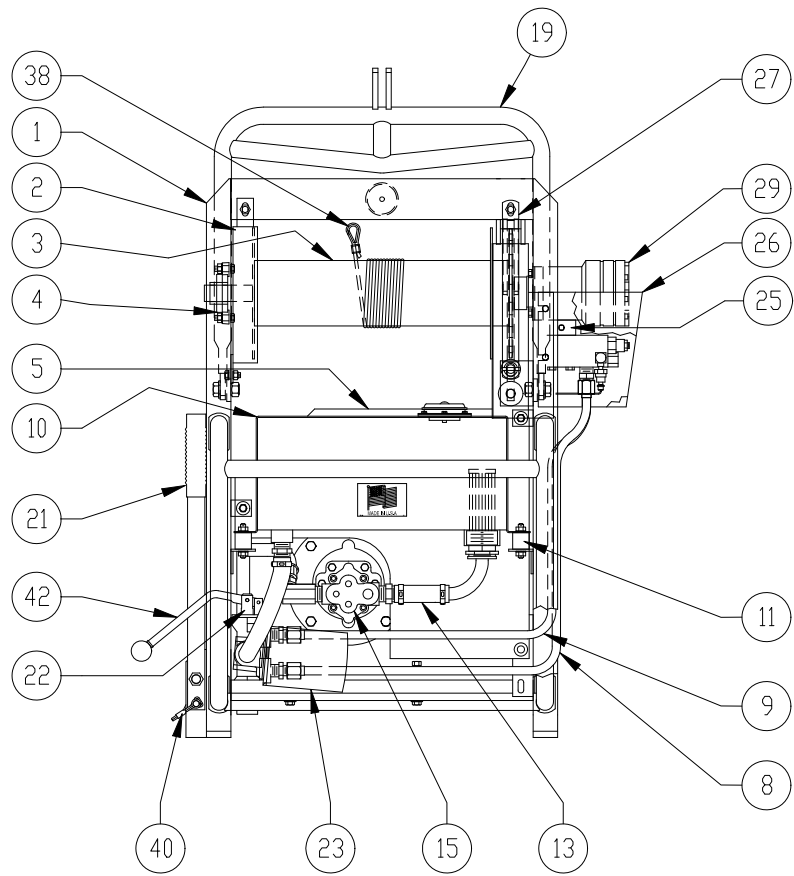

FIGURE 7-1.
HH500 AND HV500 HOIST MOUNT ASSEMBLY DRAWING

7.2 GROUND MOUNT GAS POWER DRIVE

Item Number	Part Number	Quantity	Description
1	0800101	1	FRAME
2	0804840	1	DRUM GUARD
3	0804849	1	WINCH DRUM ASSEMBLY
4	5100925	1	BEARING FLANGE
5	0801435	1	AIR BAFFLE
7	0804091	2	TUBE GUARD
8	0800758	1	LOWER TUBE
9	0800757	1	UPPER TUBE
10	0801440	1	RESERVOIR
11	5800869	4	RUBBER MOUNTS
13	5900918	2	HOSE 3/4" 6 INCH LONG
14	6000962	1	RAM/SINGLE ACTION
15	6900930	1	PUMP 6 GPM
16	6700905	1	PUMP COUPLING 9/16"
17	6700907	1	COUPLING INSERT
20	6700906	1	MOTOR COUPLING 1"
22	0804795	1	HYDRAULIC VALVE WITH GROUND MOUNT HANDLE
23	6000904	1	OIL FILTER
24	6010756	1	MOTOR LOCK VALVE
25	6000759	1	ADAPTER GAUGE PORT
26	0804848	1	GUARD HYDRAULIC MOTOR
27	0804846	1	GUARD SPROCKET
29	6500761	1	HYDRAULIC MOTOR
30	1000981	1	LOCKING ARM ASSEMBLY
31	0804845	1	GUARD-LOCK ARM
32	5800961	1	LOCK ARMSPRING
33	0855640	1	ENGINE 7.5 HP VANGUARD (HV500)
33	0855631	1	ENGINE 8 HP HONDA (HH500)
34	6900454	1	PUMP BRACKET
	6901502	1	PUMP BRACKET ACCESS COVER
35	1004155	1	LOCK ARM SPRING STUD
36	6000908	1	SUCTION STRAINER
37	6000921	1	FILTER BREATHER
38	7304212	1	WIRE ROPE ASSEMBLY (200 FEET)
41	0904075	2	GROUND MOUNT BRACKET
43	0801709	1	GROUND MOUNT HANDLE & BALL KNOB

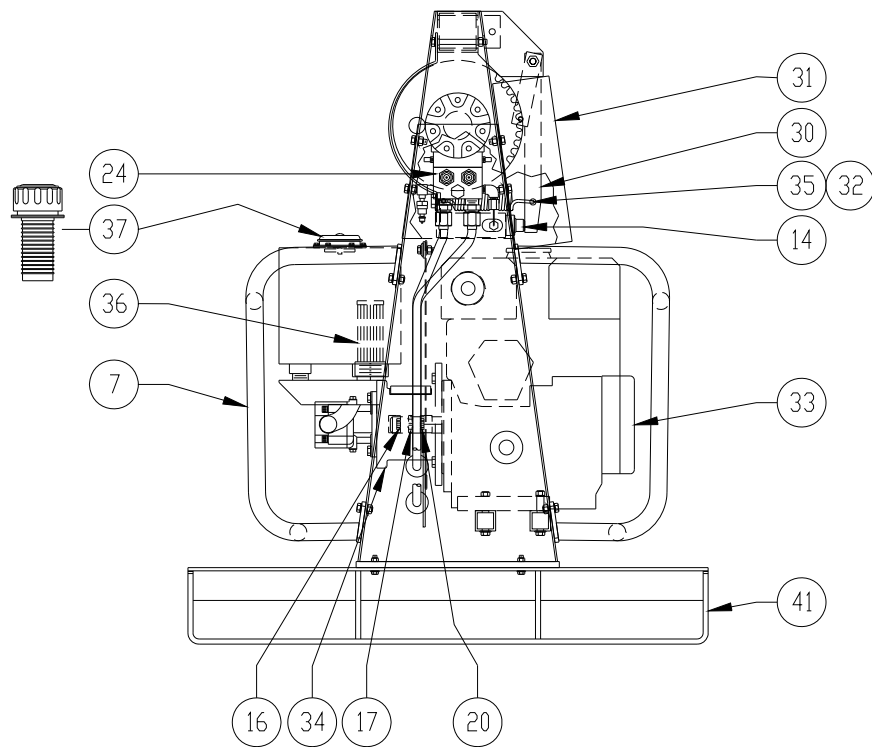
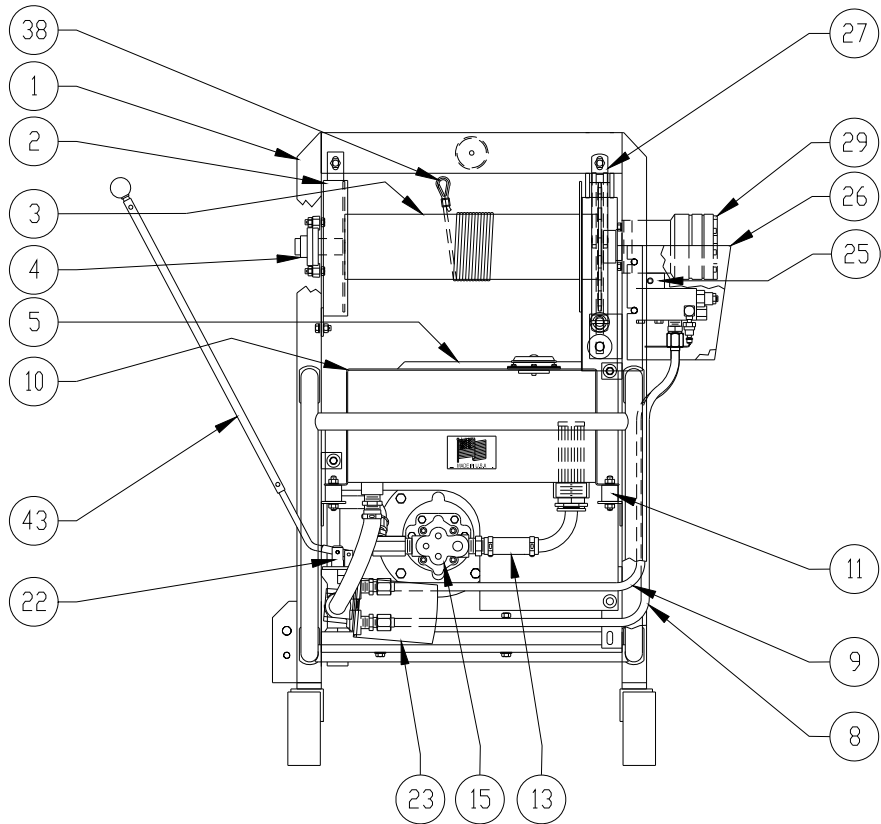

FIGURE 7-2.
HH500 AND HV500 GROUND MOUNT ASSEMBLY DRAWING

LIMITED PRODUCT WARRANTY

**Reimann & Georger Corporation
Hoisting and Construction Products**

A. LIMITED WARRANTY

Reimann & Georger Corporation (the "Manufacturer") warrants to the original purchaser (the "Buyer") that all Reimann & Georger Hoisting and Construction products shall be free of defects in material and workmanship for a period of one (1) year from date of original purchase.

B. MANUFACTURER'S OBLIGATIONS

The Manufacturer's sole obligation under this Limited Warranty is the repair or, at the Manufacturer's discretion, the replacement of parts found to be defective. Parts and equipment must have authorization from the Manufacturer prior to return to the Manufacturer or repair by an authorized service person. Costs of transportation and other expenses connected with replacing or repairing parts are not covered under this Limited Warranty.

C. PARTS MANUFACTURED BY OTHERS

This Limited Warranty does not cover any parts manufactured by others. Such parts are subject to the warranty, if any, of their respective manufacturers, and are to be repaired only by a respective authorized service person for such parts. The Manufacturer shall have no obligation to undertake repairs of parts manufactured by others.

D. NO SPECIAL, INCIDENTAL, OR CONSEQUENTIAL DAMAGES

IN NO EVENT SHALL THE MANUFACTURER BE LIABLE TO THE BUYER OR ANY OTHER PERSON FOR ANY INDIRECT, SPECIAL, INCIDENTAL OR CONSEQUENTIAL LOSSES OR DAMAGES CONNECTED WITH THE USE OF THE PRODUCT UNDER THIS LIMITED WARRANTY. SUCH DAMAGES FOR WHICH THE MANUFACTURER SHALL NOT BE RESPONSIBLE INCLUDE, BUT ARE NOT LIMITED TO, LOST TIME AND CONVENIENCE, LOSS OF USE OF THE PRODUCT, THE COST OF A PRODUCT RENTAL, COSTS OF GASOLINE, TELEPHONE, TRAVEL, OR LODGING, THE LOSS OF PERSONAL OR COMMERCIAL PROPERTY, AND THE LOSS OF REVENUE.

E. NO LIABILITY IN EXCESS OF PURCHASE PRICE

IN NO EVENT SHALL THE MANUFACTURER'S OBLIGATIONS UNDER THIS LIMITED WARRANTY EXCEED THE PURCHASE PRICE OF THE PRODUCT.

F. NO EXTENSION OF STATUTE OF LIMITATIONS

ANY REPAIRS PERFORMED UNDER THIS WARRANTY SHALL NOT IN ANY WAY EXTEND THE STATUTES OF LIMITATIONS FOR CLAIMS UNDER THIS LIMITED WARRANTY.

G. WAIVER OF OTHER WARRANTIES

THE EXPRESS WARRANTIES SET FORTH IN THIS LIMITED WARRANTY ARE IN LIEU OF AND EXCLUDE ANY AND ALL OTHER WARRANTIES, EXPRESS OR IMPLIED, INCLUDING, BUT NOT LIMITED TO, THE IMPLIED WARRANTIES OR MERCHANTABILITY AND FITNESS FOR A PARTICULAR PURPOSE.

H. PROCEDURE FOR WARRANTY PERFORMANCE

If the product fails to perform to the Manufacturer's specifications, the Buyer must provide the Manufacturer with the applicable model and serial numbers, the date of purchase, and the nature of the problem.

I. ADDITIONAL EXCLUSIONS FROM THIS LIMITED WARRANTY. THIS LIMITED WARRANTY DOES NOT COVER ANY OF THE FOLLOWING:

1. Equipment which has been abused, damaged, used beyond rated capacity, or repaired by persons other than authorized service personnel.
2. Damage caused by acts of God which include, but are not limited to, hailstorms, windstorms, tornadoes, sandstorms, lightning, floods, and earthquakes.
3. Damage under conditions caused by fire or accident, by abuse or by negligence of the user or any other person other than the Manufacturer, by improper installation, by misuse, by incorrect operation, by "normal wear and tear", by improper adjustment or alteration, by alterations not completed by authorized service personnel, or by failure of product parts from such alterations.
4. Costs of repairing damage caused by poor or improper maintenance, costs of normally scheduled maintenance, or the cost of replacing any parts unless done as the result of an authorized repair covered by the one (1) year Limited Warranty.
5. Costs of modifying the product in any way once delivered to the Buyer, even if such modifications were added as a production change on other products made after the Buyer's product was built.

J. NO AUTHORITY TO ALTER THIS LIMITED WARRANTY

No agent, representative, or distributor of the Manufacturer has any authority to alter the terms of this Limited Warranty in any way.