

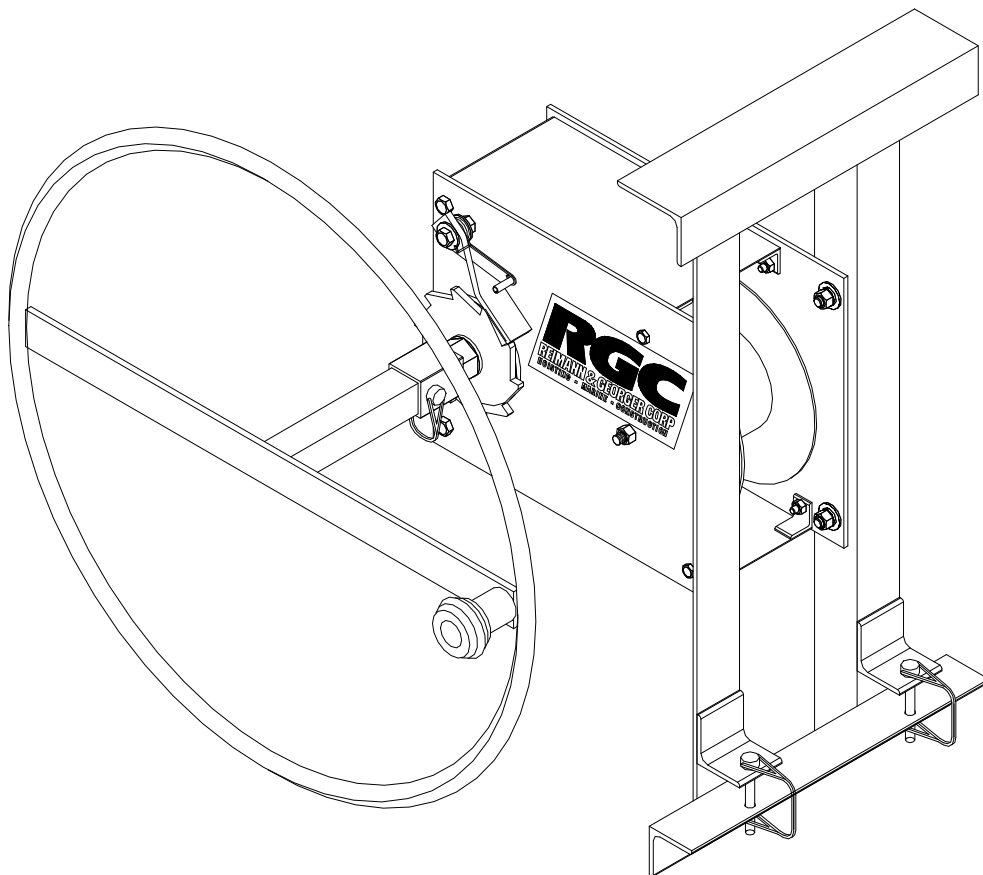

HANDIHOIST INSTRUCTIONS



REIMANN & GEORGER CORPORATION
HOISTING PRODUCTS
P/N 61-----

BUFFALO, NY
05/08/09

PRE-HOISTING CHECKLIST

This checklist must be checked prior to each use of the PRO Drive. This checklist is to be used as a guideline in conjunction with the maintenance and inspection procedures outlined in this manual. The PRO Drive and related equipment must be thoroughly inspected prior to each use by a trained person. A trained person is one who has read and thoroughly understands this instruction manual and related equipment manuals and, through training and experience, has shown knowledge regarding the safe operational procedures. If you do not have such a person in your organization, please contact Reimann & Georger Corporation or its distributors and they will assist you in providing such a “trained person.” Do not permit any person who is not fully trained to operate this PRO Drive. It is recommended that this checklist be maintained as a permanent record.

- Discuss work plan, personal protective equipment, and each crew member’s responsibility before starting to set-up.
- Ensure OSHA compliant fall protection is in place.
- Ensure hoisting operation will clear all power lines and obstructions.
- Ensure hoisting area is secured from all unauthorized personnel.
- Ensure the track is securely tied to the roof to prevent track from slipping.
- Ensure that both track shoes are resting on a firm level surface
- Ensure the load does not exceed the rated load capacity of the hoist model being used.
- Ensure all structural members of the Handihoist are free of defects and damage that may affect the integrity of the Handihoist.
- Inspect wire rope for signs of wear and damage. Replace defective wire rope immediately.
- Ensure that at least three wraps of wire rope are on the winch drum at maximum travel.
- Ensure that the screw securing wire rope end loop to the brake sheave is tight and in good condition.
- Ensure wire rope is reeved properly for either one (1) part of line for the Handihoist 200 hoist or two (2) parts of line for the Handihoist 400 hoist.
- Ensure that track support has been properly installed for track lengths over 28 feet.
- Ensure that the bottom of the track is away from the building $1/4$ of the supported height plus the building overhang.
- Ensure that all bolts and nuts are tightened securely.
- Ensure all sheaves can rotate freely.
- Ensure safety latch on the hook does not support any load.
- Ensure Handihoist has been properly maintained.
- Operate hoist with no load to test hoisting operation

INSPECTOR: _____ **DATE:** _____

TABLE OF CONTENTS

CHAPTER	DESCRIPTION	PAGE
1	SAFETY	1
1.1	Introduction	1
1.2	Safety Definitions	1
1.3	Handihoist Safety Labels	1
1.4	Handihoist Drive Safety Rules	1
2	SPECIFICATIONS	3
2.1	Handihoist Specifications	3
2.2	Complete System Specifications	3
2.3	Nameplate and Serial Number Tag	3
3	INSTALLATION AND SETUP	4
3.1	Prior to Setup	4
3.2	Handihoist Assembly	4
4	OPERATION	7
4.1	Before Operating the Handihoist	7
4.2	Raising and Lowering the Load	7
4.3	Preparing Handihoist for Shutdown	8
5	DISASSEMBLY	9
5.1	Prior to Disassembly	9
6	INSPECTION AND MAINTENANCE	10
6.1	General Maintenance Rules	10
6.2	Initial Inspection	10
6.3	Daily Inspection	10
6.4	Oiling Mechanical Parts	10
6.5	Wire Rope Inspection Procedure	10
6.6	Replacing Handihoist Wire Rope	11
7	TROUBLESHOOTING	13
8	PARTS LISTS	14
8.1	Handihoist	15

LIST OF FIGURES

FIGURE	DESCRIPTION	PAGE
2-1	Handihoist Product Nameplate	3
3-1	Handihoist Wire Rope Installation on Drum	4
3-2	Winch to Frame Assembly	5
3-3	Mounting Handihoist to Track	6
3-4	Mounting Handwheel	6
3-5	Mounting Spinner Knob to Handwheel	7
6-1	Wire Rope Components	12
8-1	Handihoist Assembly Drawing	15

1 SAFETY

1.1 INTRODUCTION

Your Reimann & Georger Corporation Handihoist has been engineered to provide lifting performance, long term economics and safety advantages that no other type can match. However, even a well-designed and well-built hoist can malfunction or become hazardous in the hands of an inexperienced and/or untrained user. Therefore, read this manual and related equipment manuals thoroughly before operating your Handihoist to provide maximum safety for all operating personnel, and to get the maximum benefit from your equipment.

1.2 SAFETY DEFINITIONS

A safety message alerts you to potential hazards that could injure you or others or cause property damage. The safety messages or signal words for product safety signs are **DANGER**, **WARNING**, and **CAUTION**. Each safety message is preceded by a safety alert symbol and is defined as follows:

DANGER: Indicates an imminently hazardous situation which, if not avoided, **will** cause death or serious injury. This safety message is limited to the most extreme situations.

WARNING: Indicates a potentially hazardous situation which, if not avoided, **could** result in death or serious injury.

CAUTION: Indicates a potentially hazardous situation which, if not avoided, **may** result in minor or moderate injury. It may also be used to alert against unsafe practices and property-damage-only accidents.

1.3 PRO DRIVE SAFETY LABELS

These labels warn you of potential hazards that could cause injury. Read them carefully. If a label comes off or becomes illegible, contact Reimann & Georger Corporation for a free replacement.

1.4 PRO DRIVE SAFETY RULES

1. Operators must be trained before operating this Handihoist. A trained person is one who has read and thoroughly understands this instruction manual and related equipment manuals and, through training and experience, has shown knowledge regarding the safe operational procedures.
2. Prior to setting up the Handihoist there must be a plan of action outlining the work to be accomplished, individual responsibilities, personal protective equipment, and method of communication.
3. All personnel shall be protected by OSHA compliant fall protection where applicable.
4. Never use the hoist structure to anchor life lines, worker's harnesses or other attachments.
5. **Always** use safety footwear, safety glasses, and head protection devices.
6. A good line of communication must be maintained between the hoist operator and the roof crew.
7. Hoisting area is to be kept clear of unauthorized personnel at all times. Place barricades or secure the area in such a manner that if there were an equipment failure, no personnel would be injured.
8. Hoisting area is to be clear of power lines. Consult the power company before you work near power lines.
9. Follow the Pre-Hoisting Checklist before operating.
10. Wear heavy leather gloves when handling wire rope.
11. Secure load before lifting.

12. Do not remove material from the platform until it has stopped completely.
13. Keep out from under a raised load.
14. Never stand in-line with the raising or lowering of the platform at either the top or bottom of the hoist track.
15. Never hoist over an open doorway.
16. Never exceed the Rated Load Capacity of 200 pounds for the Handihoist 200, or 400 pounds for the Handihoist. The Rated Load Capacity is the maximum load that should ever be applied to the hoist.
17. Avoid sudden stops and shock loads.
18. No person shall be allowed to ride on the hoist.
19. **NEVER** climb the track; use a ladder.
20. Check the hoist periodically during operation.
21. Do not attempt to make adjustments while the Handihoist is being operated.
22. Keep all body parts clear of moving parts.
23. Do not operate Handihoist when under the influence of drugs, alcohol, or medication.
24. At end of operation, the Handihoist should be secured to prevent unauthorized use. Never assume you will find the Handihoist in the same condition in which you left it.
25. Do not weld or otherwise modify the Handihoist. Such alterations may weaken the structural integrity of the hoist and will void your warranty.
26. Only trained personnel are authorized to do repairs.

2 SPECIFICATIONS

2.1 PRO DRIVE SPECIFICATIONS

MODEL	RATIO	WIRE ROPE CAPACITY
Handihoist	3:1	133'

Wire rope (all models) 5/32-in. diameter, 7 x 19 galvanized aircraft wire rope

2.2 COMPLETE SYSTEM SPECIFICATIONS

16 foot: Includes Handihoist, Platform assembly, 16-foot aluminum Track with shoes.

28 foot: Includes Handihoist, Platform assembly, 16-foot aluminum Track with shoes, additional 8 foot and 4 foot Track sections with splice plates.

44 foot: Includes Handihoist, Platform assembly, 16 foot aluminum Track with shoes, additional 16 foot, 8 foot, and 4 foot track sections with splice plates, Telescoping track support.

2.3 NAMEPLATE AND SERIAL NUMBER TAG

It is important to identify your Handihoist completely and accurately whenever ordering spare parts or requesting assistance in service. The Handihoist has a product nameplate located on the side of the frame. The label shows the model number, serial number. The Handihoist label should appear as the sample nameplate shown in Figure 2-1. Record the model and serial numbers for future reference.

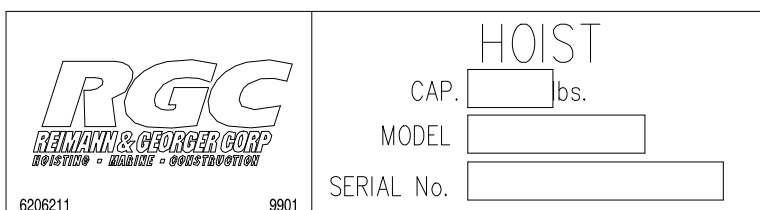

Figure 2-1.
Handihoist Product Nameplate

MODEL _____

SERIAL NUMBER _____

3 INSTALLATION AND SETUP

3.1 PRIOR TO SETUP

1. Ensure all structural members of the Handihoist are free of defects and damage that may affect the integrity of the unit.
2. Ensure the hoisting area is secured from all unauthorized personnel.
3. Before reeving the hoist, read and thoroughly understand the detailed instructions provided with your platform hoist.



WARNING:

WEAR HEAVY LEATHER GLOVES WHEN HANDLING WIRE ROPE. INSUFFICIENT HAND PROTECTION WHEN HANDLING WIRE ROPE CAN CAUSE SERIOUS PERSONAL INJURY.



WARNING:

USING DEFECTIVE WIRE ROPE CAN CAUSE EQUIPMENT DAMAGE, SERIOUS PERSONAL INJURY, OR DEATH.



WARNING:

MAKE SURE THAT BOTH TRACK SHOES ARE RESTING ON A FIRM, LEVEL SURFACE. THIS PREVENTS TRACK SLIPPAGE OR UNEVEN LOADING OF TRACK WHICH CAN CAUSE EQUIPMENT DAMAGE OR PERSONAL INJURY.

3.2 HANDIHOIST ASSEMBLY

1. Refer to figure 3.1 to attach wire rope to Handihoist drum.

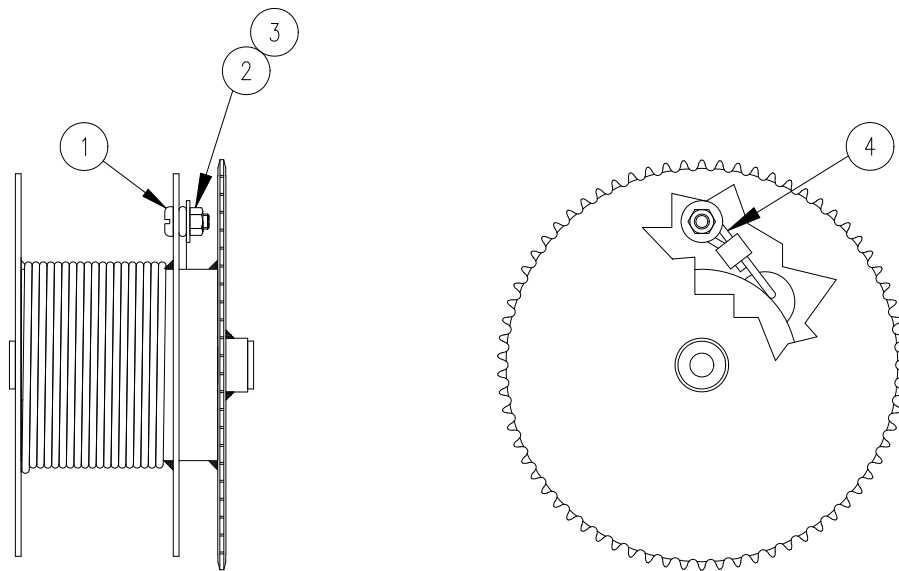

Fig. 3.1
Handihoist Wire Rope Installation on Drum

2. Refer to figure 3.2 to assemble the Handihoist winch section to the frame section.

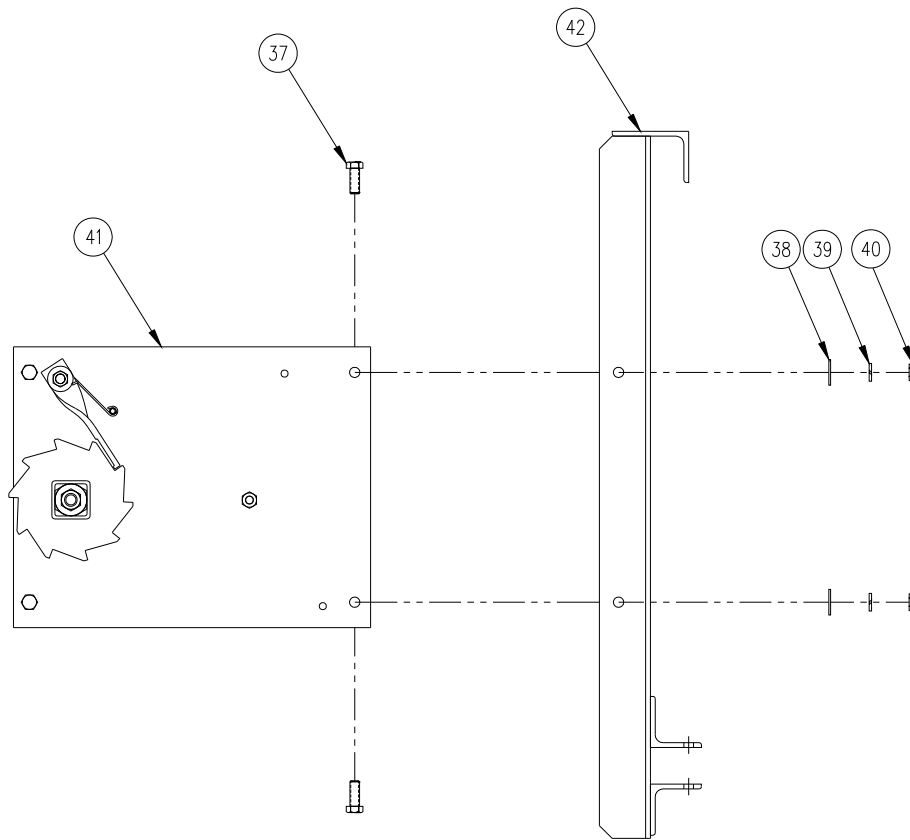

Fig. 3.2
Winch to Frame Assembly



WARNING:
ENSURE THAT OSHA COMPLIANT FALL PROTECTION IS IN PLACE.



WARNING:
PRIOR TO SETTING UP THE HOIST THERE MUST BE A PLAN OF ACTION OUTLINING THE WORK TO BE ACCOMPLISHED, INDIVIDUAL RESPONSIBILITIES, PERSONAL PROTECTIVE EQUIPMENT, AND THE METHOD OF COMMUNICATION. FAILURE TO DO THIS CAN RESULT IN DEATH, SERIOUS PERSONAL INJURY OR EQUIPMENT FAILURE.



WARNING:
ENSURE THAT ALL BOLTS AND NUTS ARE TIGHTENED SECURELY TO PREVENT EQUIPMENT DAMAGE AND/OR SERIOUS INJURY.

3. Position the Handihoist on the 3rd and 5th cross ties from the bottom as seen in fig. 3.3. Note that the 3rd and 5th cross ties are reinforced. The Handihoist should be on the underside of the track. Center the Handihoist between the track rails and lock in place by inserting the lock pins into holes in the Handihoist mounting frame.
4. Fasten the handwheel to the Handihoist as seen in fig. 3.4. When facing the Handihoist from the rear or building side of the track, the Handihoist handwheel is on your right. Details on the Handihoist operation are given in Chapter 4.

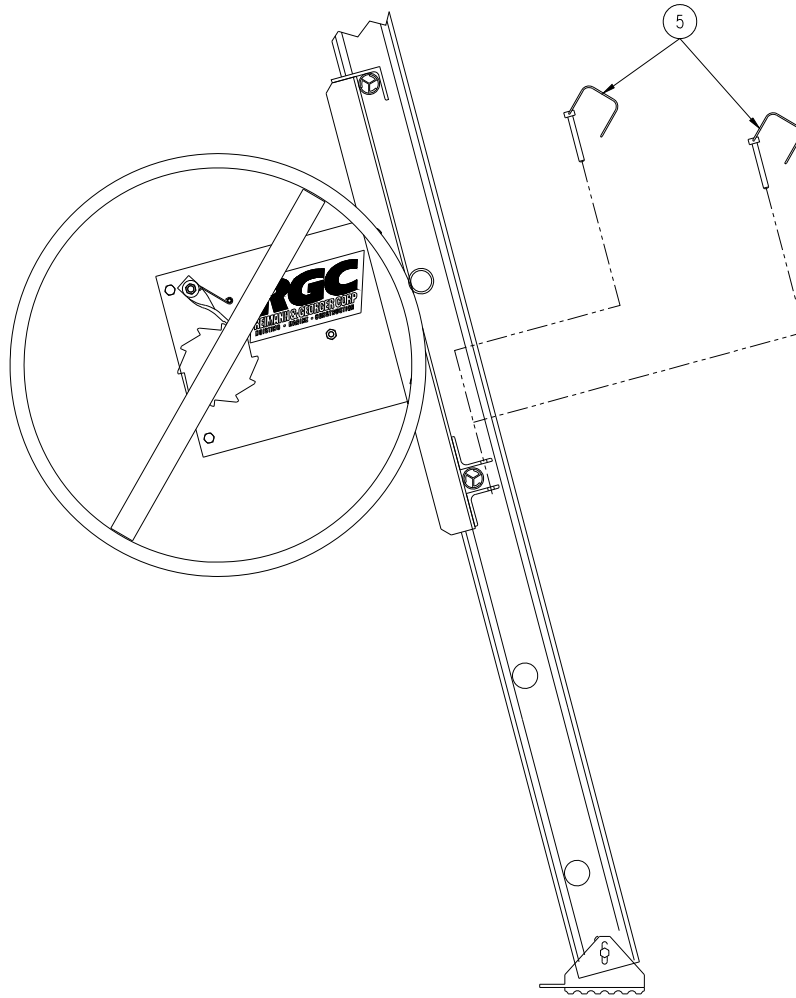

Figure 3.3
Mounting Handihoist to Track

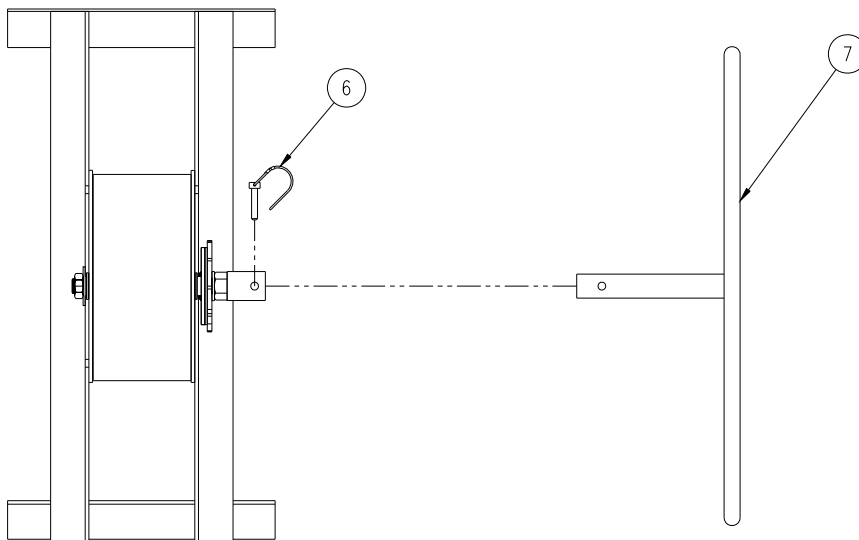

Figure 3.4
Mounting Handwheel

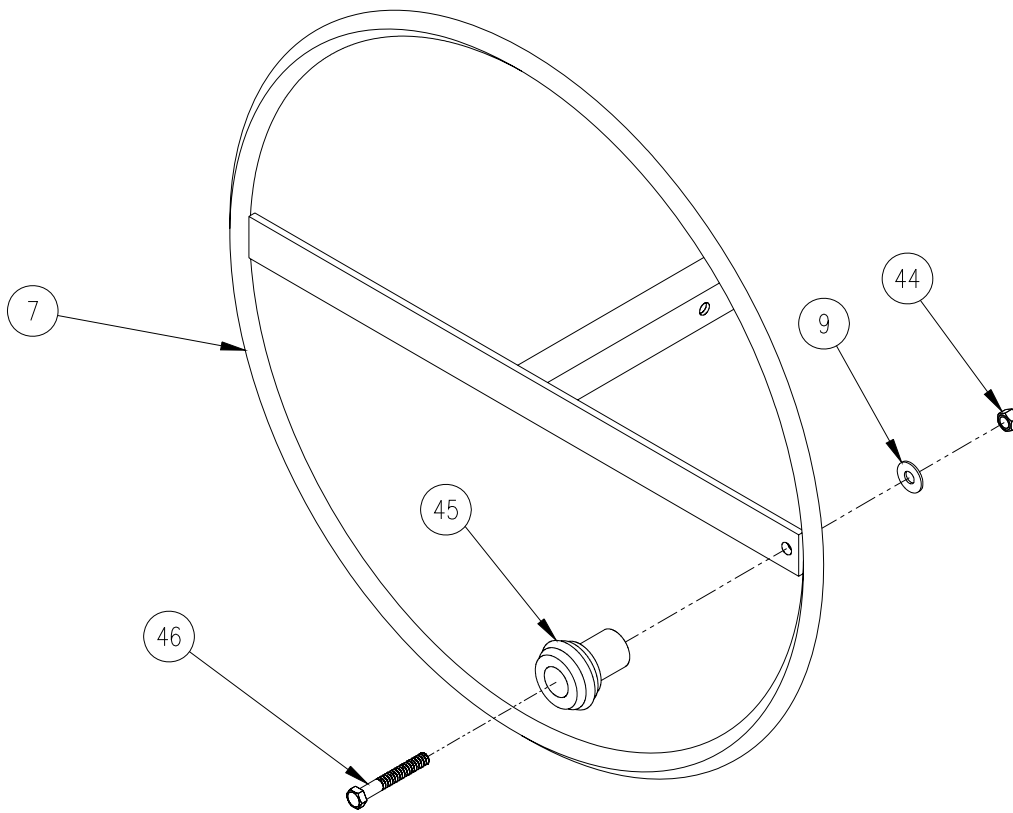

Figure 3.5
Mounting Spinner Knob to Handwheel

4 OPERATION

4.1 BEFORE OPERATING THE HANDIHOIST



WARNING:

A GOOD LINE OF COMMUNICATION MUST BE MAINTAINED BETWEEN THE HOIST OPERATOR AND THE ROOF CREW.

1. Only trained personnel shall operate this equipment. A trained person is one who has read and thoroughly understands this instruction manual and related equipment manuals and, through training and experience, has shown knowledge regarding the safe operational procedures.
2. Obey all safety labels provided on your Handihoist and platform hoist. These labels warn you of potential hazards that can cause serious injury. If a label comes off or becomes hard to read, contact Reimann & Georger Corporation for a replacement.
3. Follow the Pre-hoisting Checklist in the front of this manual before operating.
4. Never use the hoist structure to anchor lifelines, worker harnesses, or other attachments.
5. Always use safety footwear, safety glasses, and head protection devices.
6. Before lifting, ensure the safety latch on the hook is not supporting any load. Never hoist over an open doorway.



WARNING:

THE HOISTING OPERATION MUST BE CLEAR OF ALL ELECTRICAL LINES AND OBSTRUCTIONS TO PREVENT EQUIPMENT DAMAGE AND/OR SERIOUS PERSONAL INJURY. CONSULT POWER COMPANY BEFORE WORKING NEAR POWER LINES.

7. Hoisting area is to be kept clear of unauthorized personnel. Place barricades or secure the area in such a manner that if there were an equipment failure, no personnel would be injured.
8. Inspect wire rope for damage, wear, or unraveling. Replace as necessary.
9. Check all hooks and sheaves. Replace as necessary.

4.2 RAISING AND LOWERING THE LOAD



WARNING:

NEVER EXCEED THE RATED LOAD CAPACITY OF 200 POUNDS FOR THE HANDIHOIST 200 HOIST, OR 400 POUNDS FOR THE HANDIHOIST 400 HOIST. THE RATED LOAD CAPACITY IS THE MAXIMUM LOAD THAT SHOULD EVER BE APPLIED TO THE HOIST.



WARNING:

SECURE THE LOAD BEFORE LIFTING.



WARNING:

DO NOT OPERATE HOIST WHEN BRAKE ROPE IS WET

1. Before operating install the handwheel using the provided spring lock (fig 3.4).
2. Make a few “dry runs” (no load), to test hoisting operation and Handihoist



WARNING:

NEVER STAND IN-LINE WITH THE RAISING OR LOWERING OF THE PLATFORM AT EITHER THE TOP OR BOTTOM OF THE HOIST TRACK.

3. To raise the load, turn the handwheel clockwise.
4. When the platform reaches the top of the track, stop turning the handwheel. This action stops the platform and automatically applies the brake, which holds the load and platform.



WARNING:

KEEP OUT FROM UNDER A RAISED LOAD.

5. Do not allow the platform to jam against the spring stops on the top bracket.



WARNING:

DO NOT REMOVE MATERIAL FROM THE HOIST UNTIL IT HAS STOPPED COMPLETELY.

6. Turn the handwheel counterclockwise to lower platform to the ground. Do not allow the platform to strike the track shoes on reaching the bottom of the track.
7. Check the Handihoist periodically during operation.



WARNING:

KEEP ALL BODY PARTS CLEAR OF MOVING PARTS.

4.3 PREPARING HANDIHOIST FOR SHUTDOWN

At the end of operation, secure the equipment to prevent unauthorized use. **Never** assume you will find the equipment in the same condition that you left it. Proceed as follows:

1. Ensure that all lifting tension has been removed from the wire rope.
2. If the hoist is being permanently disassembled, at the end of a project for example, follow the detailed disassembly procedures in Chapter 5.

5 DISASSEMBLY

5.1 PRIOR TO DISASSEMBLY

1. Before disassembling the hoist, read and follow all the safety rules of this manual and related equipment used with the Handihoist. Failure to do this can lead to equipment damage and/or serious personal injury.
2. Ensure that the platform is not supporting any load before proceeding.
3. Before dismantling, attach a tie rope to hold the platform in position at the base of the track.
4. Ensure the track is securely tied to the roof with a rope fastened to a cross tie or top bracket to prevent track from slipping.
5. Check carefully for proximity of power lines or other overhead obstructions.



WARNING:

WEAR HEAVY LEATHER GLOVES WHEN HANDLING WIRE ROPE. INSUFFICIENT HAND PROTECTION WHEN HANDLING WIRE ROPE CAN CAUSE SERIOUS PERSONAL INJURY.

6. Tie a safety line at least 5 feet long to the wire rope end to prevent any accidental drawing of the operator's hand into the winch during rewinding.
7. **SLOWLY** turn the handwheel clockwise to rewind the wire rope. Ensure that the wire rope is rewinding evenly on the drum. As the wire rope end approaches the drum, handle the wire rope only by the safety line.
8. When the wire rope end reaches the drum, stop turning the handwheel and remove the safety line. Anchor the wire rope end on the drum with a light rope or tape.
9. Remove the handwheel from the Handihoist. Remove the lock pins from the holes provided. Then remove the Handihoist from the cross ties.

6 INSPECTION AND MAINTENANCE

6.1 GENERAL MAINTENANCE RULES

1. Proper maintenance of the Handihoist and related equipment consists of adhering to all the guidelines given in this chapter and in the Pre-Hoisting Checklist in the front of this manual. Proper maintenance is required to maintain the system in good condition, which is defined as each part being free of rust or other corrosion, bends, breaks, or other defects.
2. Review and follow all the safety rules given in Chapter 1 before attempting any maintenance.
3. Only authorized personnel should be allowed in the maintenance area. Authorized personnel are the trained people as defined below and their supervision.
4. Repairs must be made only by trained personnel. A trained person is one who has read and thoroughly understands this instruction manual and related equipment manuals and, through training and experience, has shown knowledge regarding the safe operational procedures.



WARNING:

WEAR HEAVY LEATHER GLOVES WHEN HANDLING WIRE ROPE. INSUFFICIENT HAND PROTECTION WHEN HANDLING WIRE ROPE CAN CAUSE SERIOUS PERSONAL INJURY.

5. Do not weld or otherwise modify the hoist. Such alterations may weaken the structural integrity of the hoist and invalidate your warranty.



WARNING:

DURING ANY ERECTION, MAINTENANCE, OR REPAIR PROCEDURES, DO NOT ATTEMPT ANY HOISTING. THIS CAN CAUSE EQUIPMENT DAMAGE AND/OR SERIOUS PERSONAL INJURY.



WARNING:

NEVER CLIMB THE TRACK TO DO MAINTENANCE. THIS CAN LEAD TO SERIOUS PERSONAL INJURY.

6.2 INITIAL INSPECTION

Hoist erection and dismantling must be done by trained personnel only as defined in Section 6.1. Each time after setting up the hoist and before placing it in service, all parts of the Handihoist, and other related equipment must be thoroughly inspected by trained personnel as described in the remainder of this chapter.

6.3 DAILY INSPECTION

It is important that all the maintenance procedures outlined in the Pre-Hoisting Checklist in the front of this manual be done daily. Details on inspecting the wire rope are given in Section 6.7.

All broken, worn or defective parts must be repaired or replaced before startup.

6.4 OILING MECHANICAL PARTS

1. Oil all pivots, bushings and linkage joints occasionally.

6.5 WIRE ROPE INSPECTION PROCEDURE

Inspect the wire rope prior to each use and at least daily for signs of wear, damage, or pinching. Inspect the entire wire rope working length. Thoroughly inspect the rope sections that pass over sheaves or drums, or that make opposing turns. Inspect wire rope and end attachments carefully. While inspecting, examine sheaves, guards, guides, drums, flanges, and other surfaces contacting wire rope during operation. Correct any condition harming the rope in use or other damage or worn surfaces at this time.

Remove or replace immediately wire rope with one or more of the following defects:

1. Corrosion
2. Broken wires:
 - (a) One or more valley breaks. A valley break is a wire break occurring in the valley between two adjacent strands.
 - (b) Six randomly distributed broken wires in one rope lay. A rope lay is the length of rope along which one strand makes a complete revolution around the rope. See Figure 6-1. Keeping the rope clean and wound evenly on the drum will increase its life and efficiency.
 - (c) Abrasion: Scrubbing, flattening or peening causing loss of more than one-third of the original diameter of the outside wires.
3. Kinking: Severe kinking, crushing, bird caging or other damage causing distortion of the rope structure. Bird caging is a bulging in the wire rope caused by the individual wires becoming untwisted. This untwisting of individual wires is usually caused by impact loading on the wire rope (such as a sudden stop).
4. Heat damage: Evidence of any heat damage caused by a torch or by contact with electrical wires.
5. Reduction of more than 1/64 inch from a nominal 5/16-inch or less diameter wire rope.

6.6 REPLACING HANDIHOIST WIRE ROPE

1. Refer to fig. 3.1. Loosen and remove 5/16 nut (3). Pull wire rope (4) off 5/16 bolt (1), and through hole in the drum washer.
2. Feed new wire rope (4) through hole in drum washer. Put loop of wire rope around 5/16 bolt (1) and screw on 5/16 nut (3) with 5/16 washer (2). Tighten nut (3).

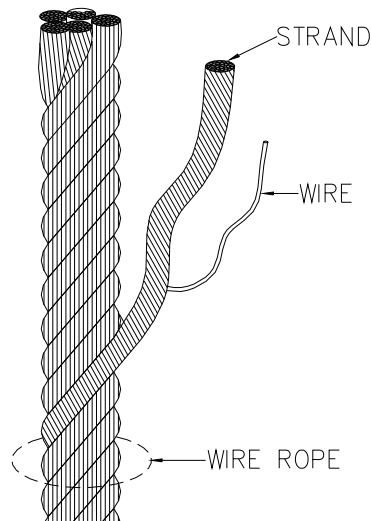

Figure 6-1.
Wire Rope Components

7 TROUBLESHOOTING

The following chart is intended to assist with troubleshooting the PRO Drive. While not all inclusive, the chart outlines the most common causes of a problem and the recommended course of action.

SYMPTOM	CAUSE AND CORRECTIVE ACTION
Handihoist won't lift load or is lifting it very slowly	Handihoist attempting to lift more than stated capacity of unit—check capacity rating and reduce load weight as needed Platform not moving freely—check for track obstructions or block and wire rope malfunctions Too much wire rope on drum—hoisting capacity decreases as wire rope diameter increases.

8 PARTS LISTS

Each item number on the following parts lists can be matched with the item number shown on the corresponding assembly drawing as indicated below.

8.1 HANDIHOIST

Refer to Figure 8-1

Item Number	Part Number	Quantity	Description
1	5806302	1	5/16-18 X 3/4 PANHEAD SCREW
2	5806401	1	5/16 WASHER
3	5806375	1	5/16-18 HEX NUT
4	7304300	1	5/32 CA ASSY X 153'
5	5800142	2	5/16 SQUARED SNAP CLEVIS PIN
6	5800138	1	5/16 ROUND SNAP CLEVIS PIN
7	0409714	1	HANDIHOIST HANDWHEEL
8	5806250	1	3/8-16 X 1-3/4 HEX BOLT
9	5806406	2	3/8 WASHER
10	3709042	1	CW PAWL
11	3705916	1	CW R18 WINCH PAWL SPACER
12	5805936	1	CW R18 PAWL SPRING
13	5806269	2	3/8-16 X 6-1/2 HEX BOLT
14	5806377	1	3/8-16 HEX NUT
15	5806756	1	1/4 X 1 SS ROLL PIN
16	5806141	5	3/8-16 SS NYLOCK HEX NUT
17	3709050	2	CW R18 SPACER
18	6709886	1	35A20 SPROCKET 1" BORE
19	5892000	1	1 SS FLAT WASHER
20	5806417	1	3/4 FLAT WASHER
21	5806191	1	3/4-16 NYLOCK HEX JAM NUT
22	0409869	2	HANDIHOIST SIDE PLATE
23	6709889	1	HH DRUM CHAIN QUICK LINK
24	6709892	1	HH DRUM CHAIN #35
25	0409702	1	HANDIHOIST DRUM AND BEARING ASSY
26	0409867	1	HANDIHOIST DRUM SHAFT
27	5809882	1	1/4 X 1/4 X 1-1/2 MACHINE KEY
28	0409701	1	HANDIHOIST INPUT SHAFT WLDMNT ZCC
29	6703833	1	4" OD FRICTION DISC
30	3701501	1	CW BRAKE RATCHET
31	5100601	2	1-1/2 OD X 7/8 ID THRUST BEARING
32	0409711	1	HANDIHOIST ACME NUT WLDMNT
33	5806400	1	1/2" FLAT WASHER
34	5816153	1	1/2-20 CENTERLOCK HEX NUT
35	5806206	4	1/4-20 X 3/4 CZP HEX BOLT
36	5806131	4	1/4-20 CZP NYLOCK HEX NUT
37	5806247	4	3/8-16 X 1 HEX BOLT
38	5806406	4	3/8 FLAT WASHER
39	5800119	4	3/8 SPLIT LOCK WASHER
40	5806377	4	3/8 HEX NUT
41	0409607	1	HANDIHOIST WINCH ASSEMBLY
42	0409705	1	HANDIHOIST FRAME WLDMNT
43	0409708	1	HANDIHOIST COVER WLDMNT
44	5806266	1	3/8-16 SS ACORN NUT
45	3603670	1	HANDWHEEL SPINNER KNOB
46	5803521	1	3/8-16 X 2-3/4 HEX BOLT

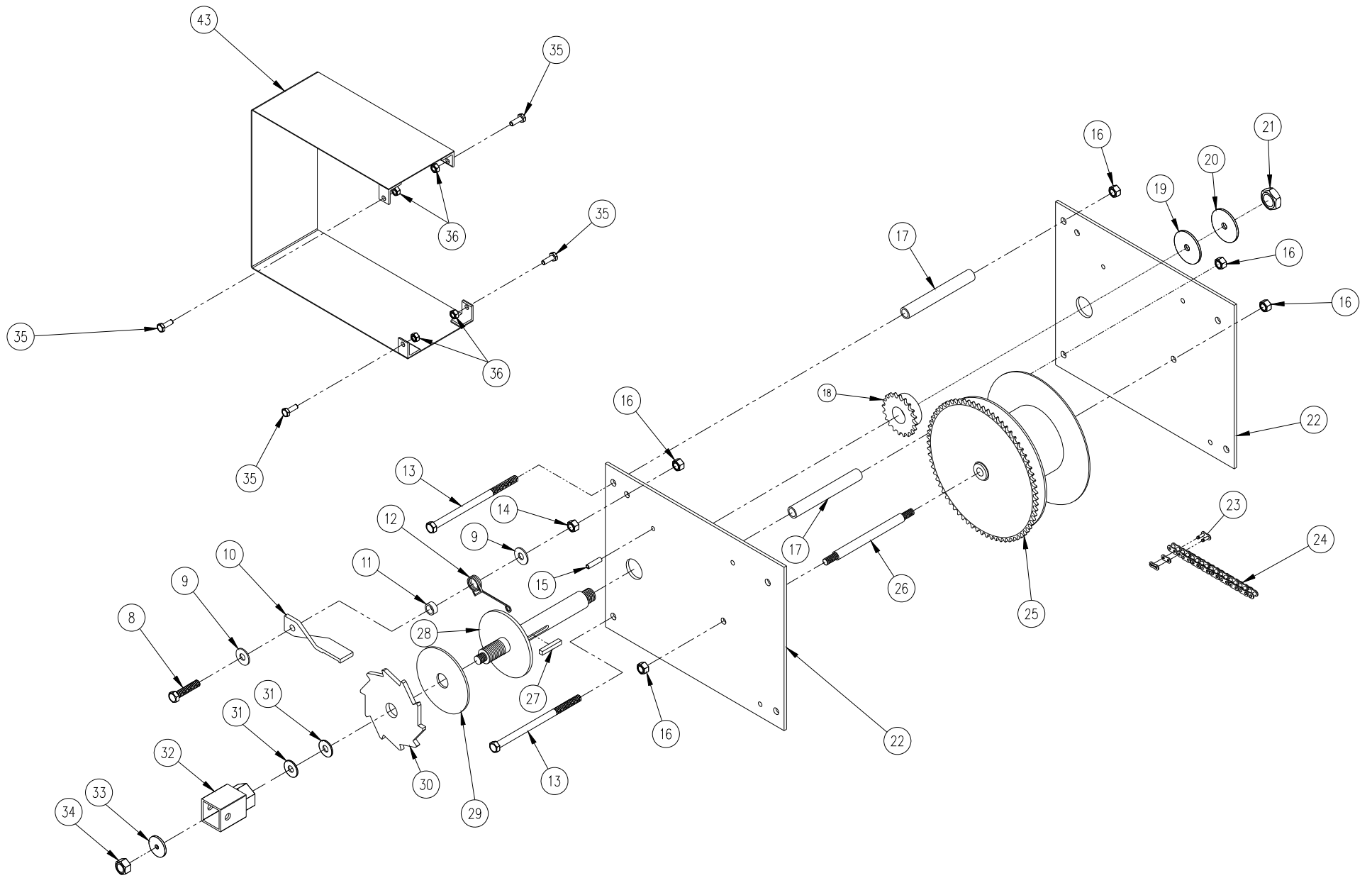

Figure 8.1

LIMITED PRODUCT WARRANTY

**Reimann & Georger Corporation
Hoisting and Construction Products**

A. LIMITED WARRANTY

Reimann & Georger Corporation (the "Manufacturer") warrants to the original purchaser (the "Buyer") that all Reimann & Georger Hoisting and Construction products shall be free of defects in material and workmanship for a period of one (1) year from date of original purchase.

B. MANUFACTURER'S OBLIGATIONS

The Manufacturer's sole obligation under this Limited Warranty is the repair or, at the Manufacturer's discretion, the replacement of parts found to be defective. Parts and equipment must have authorization from the Manufacturer prior to return to the Manufacturer or repair by an authorized service person. Costs of transportation and other expenses connected with replacing or repairing parts are not covered under this Limited Warranty.

C. PARTS MANUFACTURED BY OTHERS

This Limited Warranty does not cover any parts manufactured by others. Such parts are subject to the warranty, if any, of their respective manufacturers, and are to be repaired only by a respective authorized service person for such parts. The Manufacturer shall have no obligation to undertake repairs of parts manufactured by others.

D. NO SPECIAL, INCIDENTAL, OR CONSEQUENTIAL DAMAGES

IN NO EVENT SHALL THE MANUFACTURER BE LIABLE TO THE BUYER OR ANY OTHER PERSON FOR ANY INDIRECT, SPECIAL, INCIDENTAL OR CONSEQUENTIAL LOSSES OR DAMAGES CONNECTED WITH THE USE OF THE PRODUCT UNDER THIS LIMITED WARRANTY. SUCH DAMAGES FOR WHICH THE MANUFACTURER SHALL NOT BE RESPONSIBLE INCLUDE, BUT ARE NOT LIMITED TO, LOST TIME AND CONVENIENCE, LOSS OF USE OF THE PRODUCT, THE COST OF A PRODUCT RENTAL, COSTS OF GASOLINE, TELEPHONE, TRAVEL, OR LODGING, THE LOSS OF PERSONAL OR COMMERCIAL PROPERTY, AND THE LOSS OF REVENUE.

E. NO LIABILITY IN EXCESS OF PURCHASE PRICE

IN NO EVENT SHALL THE MANUFACTURER'S OBLIGATIONS UNDER THIS LIMITED WARRANTY EXCEED THE PURCHASE PRICE OF THE PRODUCT.

F. NO EXTENSION OF STATUTE OF LIMITATIONS

ANY REPAIRS PERFORMED UNDER THIS WARRANTY SHALL NOT IN ANY WAY EXTEND THE STATUTES OF LIMITATIONS FOR CLAIMS UNDER THIS LIMITED WARRANTY.

G. WAIVER OF OTHER WARRANTIES

THE EXPRESS WARRANTIES SET FORTH IN THIS LIMITED WARRANTY ARE IN LIEU OF AND EXCLUDE ANY AND ALL OTHER WARRANTIES, EXPRESS OR IMPLIED, INCLUDING, BUT NOT LIMITED TO, THE IMPLIED WARRANTIES OR MERCHANTABILITY AND FITNESS FOR A PARTICULAR PURPOSE.

H. PROCEDURE FOR WARRANTY PERFORMANCE

If the product fails to perform to the Manufacturer's specifications, the Buyer must provide the Manufacturer with the applicable model and serial numbers, the date of purchase, and the nature of the problem.

I. ADDITIONAL EXCLUSIONS FROM THIS LIMITED WARRANTY. THIS LIMITED WARRANTY DOES NOT COVER ANY OF THE FOLLOWING:

1. Equipment which has been abused, damaged, used beyond rated capacity, or repaired by persons other than authorized service personnel.
2. Damage caused by acts of God which include, but are not limited to, hailstorms, windstorms, tornadoes, sandstorms, lightning, floods, and earthquakes.
3. Damage under conditions caused by fire or accident, by abuse or by negligence of the user or any other person other than the Manufacturer, by improper installation, by misuse, by incorrect operation, by “normal wear and tear”, by improper adjustment or alteration, by alterations not completed by authorized service personnel, or by failure of product parts from such alterations.
4. Costs of repairing damage caused by poor or improper maintenance, costs of normally scheduled maintenance, or the cost of replacing any parts unless done as the result of an authorized repair covered by the one (1) year Limited Warranty.
5. Costs of modifying the product in any way once delivered to the Buyer, even if such modifications were added as a production change on other products made after the Buyer’s product was built.

J. NO AUTHORITY TO ALTER THIS LIMITED WARRANTY

No agent, representative, or distributor of the Manufacturer has any authority to alter the terms of this Limited Warranty in any way.