



HW1000S/HW2000S HYDRAWINCH INSTRUCTIONS

**REIMANN & GEORGER CORPORATION
HOISTING PRODUCTS
P/N 6102050**

**BUFFALO, NY
08/08/11**

TABLE OF CONTENTS

| CHAPTER | TITLE | PAGE |
|----------|--|-----------|
| 1 | SAFETY | 1 |
| 1.1 | Introduction | 1 |
| 1.2 | Safety Definitions | 1 |
| 1.3 | Safety Labels | 1 |
| 1.4 | Hoisting Safety Rules | 1 |
| 2 | SPECIFICATIONS | 3 |
| 2.1 | Technical Data..... | 3 |
| 2.2 | Nameplate And Serial Number Tag..... | 3 |
| 3 | INSTALLATION AND SETUP | 4 |
| 3.1 | Prior To Setup..... | 4 |
| 3.2 | Mounting the Winch..... | 4 |
| 3.3 | Reeving the Wire Rope..... | 4 |
| 3.4 | Raising the HydraPak to the Roof Using the Optional Hand Winch..... | 8 |
| 4 | OPERATION | 10 |
| 4.1 | Before Operating The Hoist..... | 10 |
| 4.2 | Raising And Lowering The Load | 11 |
| 4.3 | Hand Signals..... | 14 |
| 4.4 | Preparing Hoist For Shutdown | 15 |
| 5 | DISASSEMBLY | 16 |
| 5.1 | Prior To Disassembly | 16 |
| 5.2 | Rewinding The Wire Rope | 16 |
| 5.3 | Removing The Winch..... | 16 |
| 5.4 | Removing Parts From Deck..... | 16 |
| 5.5 | Lowering The Power Unit To The Ground Using the Optional Hand Winch..... | 17 |
| 6 | INSPECTION AND MAINTENANCE | 18 |
| 6.1 | General Maintenance Rules | 18 |
| 6.2 | Wire Rope Inspection Procedure | 19 |
| 7 | TROUBLESHOOTING | 20 |
| 8 | PARTS LISTS..... | 21 |
| 8.1 | HW1000S HydraWinch..... | 21 |
| 8.2 | HW2000S HydraWinch..... | 22 |

LIST OF FIGURES

| FIGURE | DESCRIPTION | PAGE |
|--------|---|------|
| 2-1 | Typical Winch Product Nameplate | 3 |
| 3-1 | Winch Mounting Position | 5 |
| 3-2 | Cable Keeper Operation | 6 |
| 3-3 | Single Line Operation up to 1000 Pounds | 7 |
| 3-4 | Double Line Operation up to 2000 Pounds | 7 |
| 3-5 | Mounting Hand Winch on HS1000..... | 9 |
| 3-6 | Mounting Hand Winch on HS2000..... | 9 |
| 4-1 | HydraPak With 5/8 GPM Control..... | 11 |
| 4-2 | HydraPak With Fixed 6 GPM Control..... | 12 |
| 4-3 | Typical HydraPak/Hoist Positioning | 13 |
| 4-4 | “Hoist” Signal | 14 |
| 4-5 | “Lower” Signal..... | 15 |
| 4-6 | “Stop” Signal..... | 15 |
| 4-7 | “Emergency Stop” Signal..... | 15 |
| 4-8 | “Move Slowly” Signal | 15 |
| 6-1 | Wire Rope Components | 19 |
| 8-1 | HydraWinch Assembly Drawing | 23 |

PRE-HOISTING CHECKLIST

This checklist or the one supplied in the swing hoist manual must be checked prior to each use of the winch. This checklist must be used in conjunction with the maintenance and inspection procedures outlined in this manual. The winch and related equipment must be thoroughly inspected prior to each use by a trained person. A trained person is one who has read and thoroughly understands this instruction manual and related equipment manuals and, through training and experience, has shown knowledge regarding the safe operational procedures. If you do not have such a person in your organization, please contact Reimann & Georger Corporation or its distributors and they will assist you in providing such a “trained person.” Do not permit any person who is not fully trained to operate the winch or hoist. This checklist should be maintained as a permanent record.

- Discuss work plan, personal protective equipment, and each crew member’s responsibility before starting to set-up. All crew members must be familiar with the use of hand signals.
- Ensure OSHA compliant fall protection is in place.
- Ensure a competent person (qualified engineer) has determined the structural deck can support the intended loads in hoisting and material handling.
- Ensure hoisting operation will clear all power lines and obstructions.
- Ensure hoisting area is secured from all unauthorized personnel.
- Ensure that all hoisting accessories such as forks, buckets, and slings are commercially manufactured, are in good condition, and have a rated load capacity.
- Capacity of slings decreases as the angle increases. Ensure slings have a capacity of at least 1000 lbs. for an HS1000 hoist or 2000 lbs. for an HS2000 hoist and are in good condition.
- Inspect wire rope for signs of wear and damage. Replace defective wire rope immediately.
- Ensure that at least three wraps of wire rope are on the winch drum at maximum travel.
- Ensure bolt securing wire rope end loop to the drum flange is tight and in good condition.
- Ensure wire rope is unwinding from the top and not the bottom of the winch drum.
- Ensure there is sufficient weight on the wire rope to maintain 10-20 lbs. of tension at all times.
- Ensure wire rope is reeved properly for either one (1) part of line for 1000 lbs. capacity or, on the HS2000 hoist, two (2) parts of line for 2000 lbs. capacity.
- Ensure the two pins and hairpins between the winch and counterweight leg are connected and in good condition.
- Ensure upper and lower sections of counterweight legs are bolted together using grade 5 bolts and nuts with shake washers, are tightened to a torque between 60-75 ft.-lbs., and are in good condition.
- Ensure the Operator Fence is lowered.
- Ensure all structural members of the hoist are free of defects and damage that may affect the integrity of the hoist.
- Ensure that either 1000 lbs. (Ontario OHSA: 570 kg.) or 2000 lbs. (Ontario OHSA: 1140 kg.) of Reimann & Georger Corporation approved ballast blocks are secured in the counterweight basket of the HS1000 and HS2000 respectively.
- Ensure 3/4” plywood is placed under counterweight basket to distribute the weight.
- Ensure vertical leg is vertically plumb.

PRE-HOISTING CHECKLIST (continued)

- Ensure front leg is mounted to 2" X 6" lumber to distribute load along the roof edge.
- Ensure all pinned connections are made on the hoist frame and all pins and hairpins are in good condition.
- Ensure all lock screws are tightened.
- Ensure boom pins are completely engaged in the front leg sockets.
- Ensure bolt through the pivot sheave is in good condition and is held securely in place with a locknut.
- Ensure pivot sheave can rotate freely.
- Ensure bolt through the boom sheave is in good condition and is held securely in place with a locknut.
- Ensure boom sheave can rotate freely.
- Ensure the pin through the cable keeper is in good condition and is securely in place.
- Ensure cable keeper is in the locked position.
- Ensure the swivel hook on an HS1000 hoist has a rated capacity of at least 1000 lbs. and is in good condition.
- Ensure the block and swivel hook on an HS2000 hoist have a rated capacity of at least 2000 lbs. and are in good condition.
- Ensure safety latch on the hook does not support any load.
- Ensure all shackles have a rated capacity of at least 1000 lbs. for an HS1000 hoist or 2000 lbs. for an HS2000 hoist and are in good condition.
- Ensure power unit has been properly maintained.
- Ensure hydraulic hoses are properly connected and in good condition.
- Operate hoist with no load to test hoisting operation, controls, and power unit.

INSPECTOR: _____ **DATE:** _____

1 SAFETY

1.1 INTRODUCTION

Your Reimann & Georger Corporation HW1000S and HW2000S Hydraulic Winches have been engineered to provide lifting performance, long term economics and safety advantages that no other type can match. However, even a well-designed and well-built winch can malfunction or become hazardous in the hands of an inexperienced and/or untrained user. Therefore, read this manual and related equipment manuals thoroughly before operating your winch to provide maximum safety for all operating personnel, and to get the maximum benefit from your equipment.

1.2 SAFETY DEFINITIONS

A safety message alerts you to potential hazards that could injure you or others or cause property damage. The safety messages or signal words for product safety signs are **DANGER**, **WARNING**, and **CAUTION**. Each safety message is preceded by a safety alert symbol and is defined as follows:

DANGER: Indicates an imminently hazardous situation which, if not avoided, **will** cause death or serious injury. This safety message is limited to the most extreme situations.

WARNING: Indicates potentially hazardous situation which, if not avoided, **could** result in death or serious injury.

CAUTION: Indicates a potentially hazardous situation which, if not avoided, **may** result in minor or moderate injury. It may also be used to alert against unsafe practices and property-damage-only accidents.

1.3 SAFETY LABELS

Labels are provided with the winch and associated hoist and HydraPak that warn you of potential hazards that can cause injury. Read them carefully. If a label comes off or becomes illegible, contact Reimann & Georger Corporation for a free replacement.

1.4 HOISTING SAFETY RULES

1. Operators must be thoroughly trained before operating the winch and hoist. A trained person is one who has read and thoroughly understands this instruction manual and related equipment manuals and, through training and experience, has shown knowledge regarding the safe operational procedures.
2. Prior to setting up the hoist there must be a plan of action outlining the work to be accomplished, individual responsibilities, personal protective equipment, and method of communication.
3. A good line of communication must be maintained between the hoist operator and the ground crew. All crew members must be familiar with hand signals.
4. Follow the Pre-Hoisting Checklist before operating.
5. Use only Reimann & Georger Corporation approved ballast blocks or factory approved equal as counterweight.
6. Ensure that 1000 lbs. (Ontario OHSA: 570 kg.) of ballast blocks are secured properly in the lower counterweight basket before operating an HS1000 hoist. Ensure that 2000 lbs. (Ontario OHSA: 1140 kg.) of ballast blocks are secured properly in the lower counterweight basket before operating an HS2000 hoist. Tie ballast blocks to basket with rope. **No** human being shall **ever** be utilized as ballast.
7. Wear heavy leather gloves when handling wire rope.
8. All personnel shall be protected by OSHA compliant fall protection.
9. Never use the hoist structure to anchor life lines, worker's harnesses or other attachments.
10. Hoist operator must stand behind the operator fence while the hoist is operating.

11. Hoisting area is to be clear of power lines. Consult power company before you work near power lines.
12. Hoisting area is to be kept clear of unauthorized personnel at all times. Place barricades or secure the area in such a manner that if there were an equipment failure, no personnel would be injured.
13. Keep out from under a raised load.
14. Never hoist over an open doorway.
15. Use the HW1000S winch only on the HS1000 hoist and never exceed the Rated Load Capacity of 1000 lbs. Use the HW2000S winch only on the HS2000 hoist and never exceed the Rated Load Capacity of 1000 lbs. for single line pull or 2000 lbs. for double line pull. The Rated Load Capacity is the maximum load that should ever be applied to the hoist. Rated Load Capacity is for straight line pull; avoid side loads.
16. Avoid sudden stops and shock loads.
17. All hoisting accessories such as forks, buckets and slings must be commercially manufactured.
18. All hooks, slings, shackles, and other hoisting accessories must be properly maintained and installed.
19. Secure load before lifting.
20. Tag lines shall be used to control all loads.
21. No person shall be allowed to ride on the hoist.
22. Do not climb the hoist; use only a step ladder with OSHA compliant fall protection. Do **not** use an extension ladder.
23. Check the hoist periodically during operation.
24. Do not disconnect hydraulic hoses or fittings while hydraulic power source is running.
25. Do not attempt to make adjustments while the hoist is being operated.
26. Keep all body parts clear of moving parts.
27. At end of operation, the hoist should be secured to prevent unauthorized use. Never assume you will find the hoist in the same condition in which you left it.
28. Do not weld or otherwise modify the winch or hoist. Such alterations may weaken the structural integrity of the winch or hoist.
29. Only trained personnel are authorized to do repairs.
30. Do not operate hoist when under the influence of drugs, alcohol, or medication.

2 SPECIFICATIONS

2.1 TECHNICAL DATA

The following specifications apply to the HydraWinch. Detailed specifications for the hoist assembly and the HydraPak are in the separate manuals for these items.

| | HW1000S | HW2000S |
|---------------------------------|----------------|-----------------------------------|
| Winch capacity | 1000 lbs. | 1000/2000 lbs. |
| Maximum lifting speed | up to 165 fpm | up to 165 fpm (1 part of line) |
| Winch wire rope supplied | 150 ft. | 200 ft. |
| Winch wire rope—maximum length* | 300 ft. | 300 ft. |
| Weight | 118 lbs. | 124 lbs. |

* Consult factory for longer wire rope lengths.

2.2 NAMEPLATE AND SERIAL NUMBER TAG

It is important to identify your winch completely and accurately whenever ordering spare parts or requesting assistance in service. The winch has a product nameplate that shows the model and serial numbers and capacity rating. The winch label should appear as the sample nameplate shown in Figure 2-1. Record the model and serial numbers, and capacity rating for future reference.



Figure 2-1.
Typical Winch Product Nameplate

MODEL _____

SERIAL NUMBER _____

CAPACITY RATING _____

3 INSTALLATION AND SETUP

3.1 PRIOR TO SETUP

1. Ensure the hoist frame has been assembled as detailed in the HS1000 or HS2000 manual.



WARNING:

ENSURE ALL STRUCTURAL MEMBERS OF THE HOIST ARE FREE OF DEFECTS AND DAMAGE THAT MAY AFFECT THE INTEGRITY OF THE UNIT.

2. Ensure that the proper HydraWinch is being installed on the hoist. The HW1000S is used **only** on the HS1000 hoist and the HW2000S is used **only** on the HS2000 hoist.



WARNING:

ENSURE THE HOISTING AREA IS SECURED FROM ALL UNAUTHORIZED PERSONNEL. ENSURE THAT OSHA COMPLIANT FALL PROTECTION IS IN PLACE.



WARNING:

A COMPETENT PERSON MUST DETERMINE THAT THE STRUCTURAL DECK CAN SUPPORT THE INTENDED LOADS IN HOISTING AND MATERIAL HANDLING IN ADDITION TO THE WEIGHT OF THE COUNTERWEIGHT ON THE ROOF DECK. FAILURE TO DO THIS CAN RESULT IN DEATH, SERIOUS PERSONAL INJURY OR EQUIPMENT FAILURE.



WARNING:

PRIOR TO SETTING UP THE HYDRAWINCH FOR HOISTING, THERE MUST BE A PLAN OF ACTION OUTLINING THE WORK TO BE ACCOMPLISHED, INDIVIDUAL RESPONSIBILITIES, PERSONAL PROTECTIVE EQUIPMENT, AND THE METHOD OF COMMUNICATION. FAILURE TO DO THIS CAN RESULT IN DEATH, SERIOUS PERSONAL INJURY OR EQUIPMENT FAILURE.

3.2 MOUNTING THE WINCH

1. Ensure hydraulic hoses are disconnected from winch before mounting.
2. Place the winch in position on the counterweight leg as shown in Figure 3-1.
3. Secure winch to counterweight leg using the two pins and hairpins.



WARNING:

ENSURE THE TWO PINS AND HAIRPINS BETWEEN THE WINCH AND COUNTERWEIGHT LEG ARE PROPERLY CONNECTED AND IN GOOD CONDITION.

4. Do not connect the hydraulic hoses until you are ready to reeve the wire rope.

3.3 REEVING THE WIRE ROPE

1. Ensure that the HydraPak is fully operational and that you have read the separate operating instructions for the HydraPak.

2. Ensure that the bolt securing the wire rope end loop to the drum flange is tight and in good condition. Pull out at least 5 feet of wire rope manually off the winch to prevent any accidental drawing of the operator's hand into the winch during HydraPak operation. Ensure wire rope is unwinding from the top and not the bottom of the winch drum.

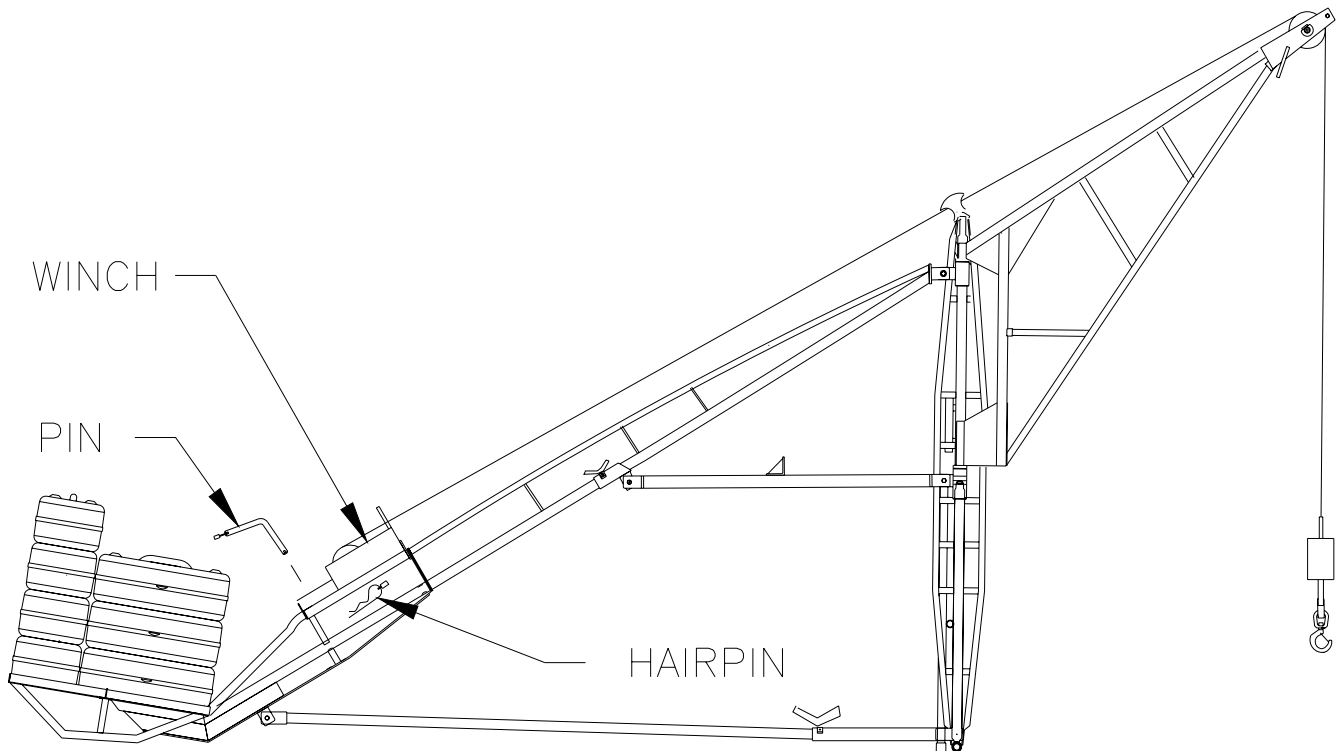

Figure 3-1.
Winch Mounting Position

3. Attach the 1/2" hydraulic hoses from HydraPak to the winch. Attach the 1/4" hydraulic hoses from HydraPak to the cylinder.
4. If using the HS1000 hoist, start the HydraPak and run at an idle. "Feather" the winch control lever downward to unwind about 25 feet of wire rope for 1 part reeving. This length will place the lifting hook at about eye level at the completion of the reeving procedure.
5. If using the HS2000 hoist, start the HydraPak and run at an idle in the 5 GPM position. "Feather" the winch control lever downward to unwind about 23 feet of wire rope for 1 part reeving or about 30 feet of wire rope for 2 part reeving. These lengths will place the lifting hook at about eye level at the completion of the reeving procedure.
6. Rotate the boom in over the roof deck to reeve the wire rope.
7. Using OSHA compliant fall protection, use a step ladder (not an extension ladder) to reeve wire rope through guide on winch and then through pivot block or sheave. At top of boom, unlock cable keeper by pulling out handle and rotating it counterclockwise as shown in Figure 3-2. Insert wire rope between cable keeper and sheave. Lock cable keeper in position by pulling out handle and rotating it clockwise as shown in Figure 3-2. This handle is spring loaded and has to be pulled out to rotate in either direction.



WARNING:
NEVER CLIMB ON THE HOIST FRAME.

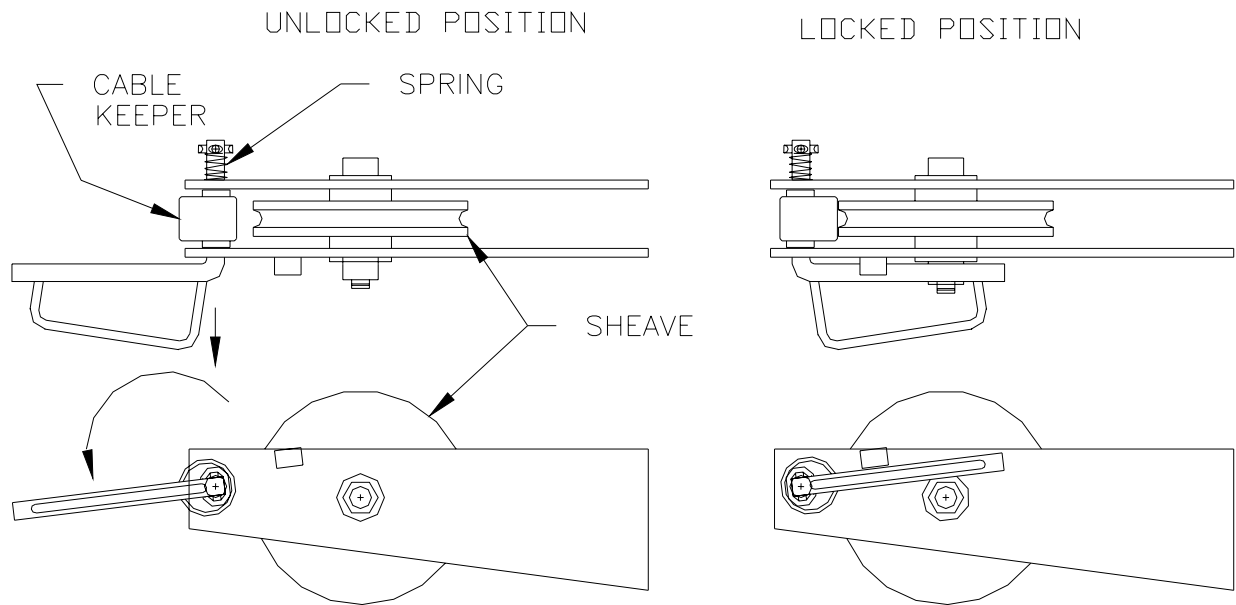

Figure 3-2.
Cable Keeper Operation

8. Before applying any load, inspect the wire rope for wear as detailed in Chapter 6.



WARNING:
DISCARD DEFECTIVE WIRE ROPE IMMEDIATELY.

9. For single line lifting, attach shackle and safety hook as shown in Figure 3-3. For double line lifting, reeve wire rope through block and attach shackle and safety hook. Secure to lifting hook on boom as shown in Figure 3-4.



WARNING:
ENSURE BLOCK, SHACKLE, AND HOOK HAVE AT LEAST THE SAME RATED CAPACITY AS THE HOIST AND ARE IN GOOD CONDITION.

10. When replacing or rewinding wire rope, insure wire rope is feeding onto **top** side of the drum. If the wire rope feeds onto the bottom of the drum, the HydraPak up/down winch control lever will operate in the reverse sense. The winch will operate with an audible ratcheting noise and will not function properly.

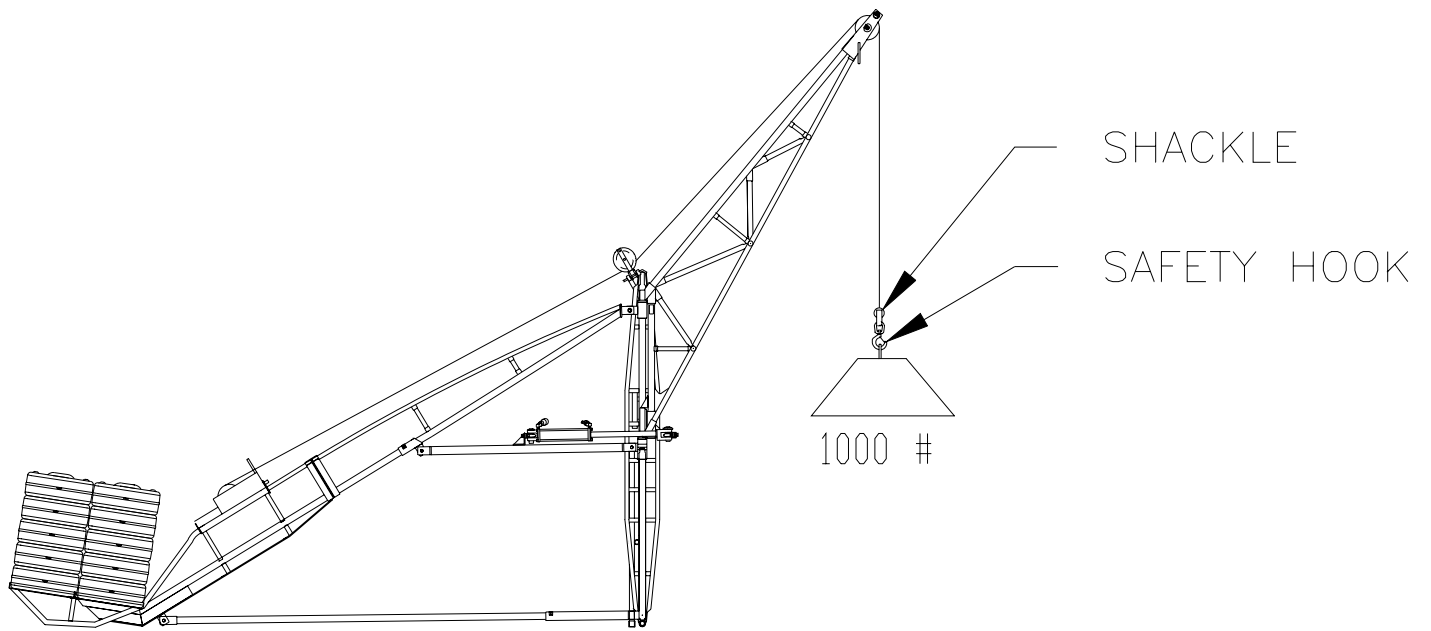

Figure 3-3.
Single Line Operation Up to 1000 Pounds (HS2000 shown)

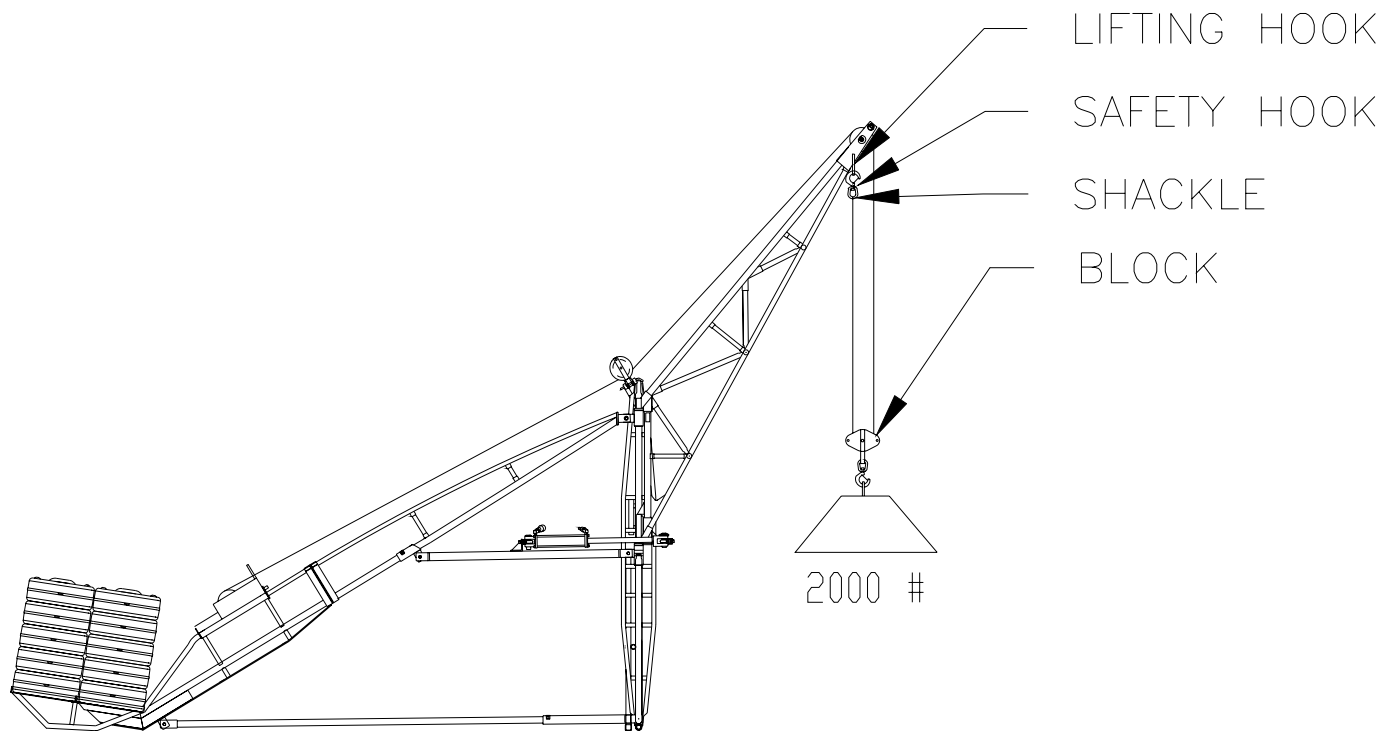

Figure 3-4.
Double Line Operation Up to 2000 Pounds (HS2000 only)

3.4 RAISING THE HYDRAPAK TO THE ROOF USING THE OPTIONAL HAND WINCH

If a freight elevator or other transporting medium is not available to raise the HydraPak to the roof, it can be done using the hand winch as follows.



WARNING:

THE HAND WINCH IS NOT A MATERIAL HOIST. USE ONLY FOR RAISING AND LOWERING THE HYDRAPAK. DO NOT HOIST CONSTRUCTION OR DEMOLITION MATERIAL.

1. Before raising the HydraPak to the roof, check the following:
 - a. The hoist should be fully assembled except for the winch and cylinder. If the cylinder is installed, remove it because the boom will be locked in position.
 - b. Ensure that either 20 ballast blocks (1000 lbs.) for the HS1000 hoist or 40 ballast blocks (2000 lbs.) for the HS2000 hoist are secured in the counterweight basket.



WARNING:

BEFORE RAISING THE POWER UNIT, ENSURE 1000 LBS. FOR THE HS1000 HOIST OR 2000 LBS. FOR THE HS2000 HOIST OF REIMANN & GEORGER CORPORATION APPROVED BALLAST BLOCKS ARE SECURED IN THE LOWER COUNTERWEIGHT BASKET.



WARNING:

NEVER USE HUMAN BEINGS AS COUNTERWEIGHT.

- c. Install a tether line to the boom for swinging it over the rooftop to unload the HydraPak.
2. Mount the hand winch on the hoist so the crank is located on the right-hand side.
 - a. If using the HS1000 hoist, the winch is located on the upper counterweight leg such that the space between the front of the mounting plate and the angle clip fits over the counterweight leg cross-brace. Secure the winch in place by clamping the mounting plate to the counterweight leg with the angle clamp. See Figure 3-5.
 - b. If using the HS2000 hoist, locate the winch on the lower counterweight leg by sliding the front lip of the winch mounting plate under the frame of upper/lower counterweight leg joint. Align the mounting holes and secure with the provided hardware. See Figure 3-6.
3. Before reeving the wire rope, rotate the boom in over the deck and tie securely to the counterweight leg. Using a step ladder with OSHA compliant fall protection, reeve the wire rope through the pivot sheave and then between the cable keeper and the boom sheave. Always wear heavy leather gloves when handling wire rope.



WARNING:

WIRE ROPE MUST BE FEEDING OFF THE BOTTOM OF THE HAND WINCH DRUM FOR PROPER BRAKE OPERATION.

4. Inspect the wire rope for signs of wear and damage. Replace defective wire rope immediately.



WARNING:

NEVER CLIMB THE HOIST FRAME TO REEVE THE WIRE ROPE. USE A STEP LADDER (NOT AN EXTENSION LADDER) WITH OSHA COMPLIANT FALL PROTECTION.

5. Connect the wire rope to the lifting eye on the HydraPak. Insure the hook fastens securely to the lifting eye.
6. Attach a tag line to the HydraPak frame to control swaying during the raising of the power unit.
7. The operator on the roof cranks the winch clockwise to raise the HydraPak.



WARNING:
ALWAYS STAND CLEAR OF THE SUSPENDED UNIT.

8. Use the boom tether to swing the HydraPak over to the roof top.
9. The roof operator cranks the winch counterclockwise to lower the HydraPak.

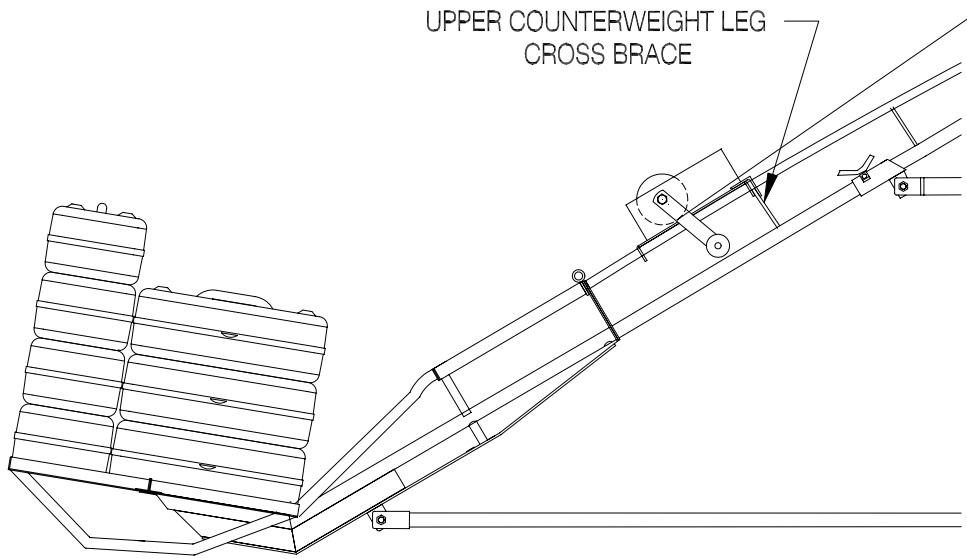

Figure 3-5.
Mounting Hand Winch on HS1000

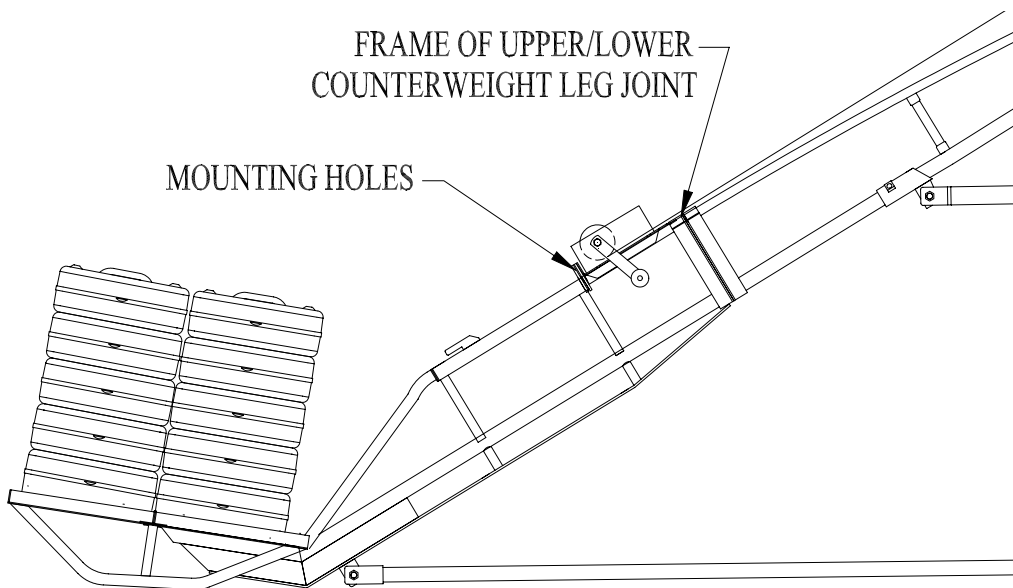

Figure 3-6.
Mounting Hand Winch on HS2000

4 OPERATION

4.1 BEFORE OPERATING THE HOIST



WARNING:

ONLY TRAINED PERSONNEL SHALL OPERATE THIS EQUIPMENT. A TRAINED PERSON IS ONE WHO HAS READ AND THOROUGHLY UNDERSTANDS THIS INSTRUCTION MANUAL AND RELATED EQUIPMENT MANUALS AND, THROUGH TRAINING AND EXPERIENCE, HAS SHOWN KNOWLEDGE REGARDING THE SAFE OPERATIONAL PROCEDURES.



WARNING:

FOLLOW THE PRE-HOISTING CHECKLIST IN THE FRONT OF THIS MANUAL BEFORE OPERATING.

1. Read the safety labels provided with your hoist and HydraPak. These labels warn you of potential hazards that can cause serious injury. If a label comes off or becomes hard to read, contact Reimann & Georger Corporation for a free replacement.
2. Before starting operation, you must thoroughly read your HydraPak and hoist instruction manuals for complete safety, operating and maintenance information.



WARNING:

THE HOISTING OPERATION MUST BE CLEAR OF ALL ELECTRICAL LINES AND OBSTRUCTIONS. CONSULT POWER COMPANY BEFORE WORKING NEAR POWER LINES.

3. Hoisting area is to be kept clear of unauthorized personnel. Place barricades or secure the area in such a manner that if there were an equipment failure, no personnel would be injured.
4. Ensure that all hoisting accessories such as forks, buckets and slings are commercially manufactured, are in good condition, and have a rated load capacity. When using a sling, note that its capacity decreases as the angle increases.
5. Before making any hydraulic connections, inspect all hoses for leaks and risks of rupture as follows:
 - a. Inspect each hose for cuts, cracks, worn spots, bulges, chemical attack, kinks or any other damage. Never stop any detected leak with your hand.
 - b. Replace a damaged hose immediately. Never repair the hose.



WARNING:

LIQUID UNDER HIGH PRESSURE CAN PIERCE THE SKIN, CAUSING DEATH OR SERIOUS INJURY. IN CASE OF INJURY, GET IMMEDIATE MEDICAL ATTENTION.

6. Connect the hydraulic hoses from the HydraPak to the HydraWinch. To connect, retract sleeve on the female coupling and insert male coupling. To disconnect, retract sleeve on female coupling and remove male coupling.
7. Ensure hydraulic hoses are connected from the HydraPak to the cylinder.
8. Use caution when handling fuel for the HydraPak. Make sure the gas caps on the HydraPak and fuel can are properly tightened. Move the HydraPak at least 10 feet from the fueling point before starting the engine.

4.2 RAISING AND LOWERING THE LOAD



WARNING:

EITHER 1000 LBS. (ONTARIO OHSA: 570 KG.) FOR AN HS1000 HOIST OR 2000 LBS. (ONTARIO OHSA: 1140 KG.) FOR AN HS2000 HOIST OF REIMANN & GEORGER CORPORATION APPROVED BALLAST BLOCKS MUST BE SECURED PROPERLY IN THE LOWER COUNTERWEIGHT BASKET WITH ROPE BEFORE OPERATING THE HOIST.



WARNING:

NEVER EXCEED THE RATED LOAD CAPACITY OF 1000 OR 2000 LBS.



WARNING:

NEVER USE HUMAN BEINGS AS COUNTERWEIGHT.

1. Determine what HydraPak output you will need, if applicable:
 - a. The 5/8 lever provides an output of either 5 or 8 GPM. See Figure 4-1. This selection allows the hydraulic winch to operate at two different speed ranges. Within these ranges, engine speed can be varied to further adjust hoisting speeds. Speeds are variable to about 165 fpm with a single part of line. A speed of up to 80 fpm is available when using the HS2000 with two parts of line. As wire rope is wound onto the drum, the diameter of the wire rope on the drum increases which increases lifting speed but decreases lifting capacity.

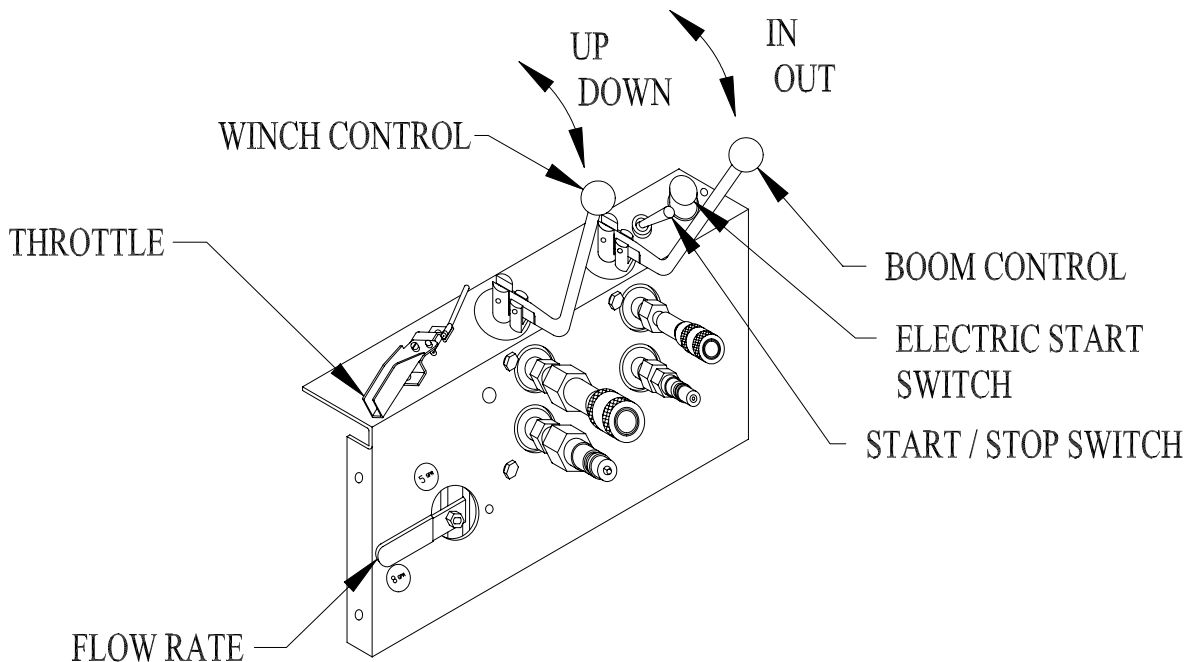

Figure 4-1.
HydraPak With 5/8 GPM Control

- b. If using an HS1000 hoist, use 8 GPM for light loads (under 750 lbs.). For heavy loads (up to 1000 lbs. capacity), use 5 GPM. To further slow lifting speed, run the engine at reduced throttle.

- c. If using an HS2000 hoist, use 8 GPM for light loads, less than 1000 lbs. with two parts of line or 500 lbs. with single part of line. At the 8 GPM setting, the line speed is 165 feet per minute with a single part of line or 83 feet per minute with two parts of a line. For heavy loads (up to 2000 lbs. capacity), use 5 GPM and two parts of a line. To further slow lifting speed, run the engine at reduced throttle. One and two part of a line reeving is illustrated in Chapter 3.
2. For HydraPaks with a fixed 6 GPM output, control lifting speed by running the engine at partial throttle. Speeds are variable to about 140 fpm. See Figure 4-2.

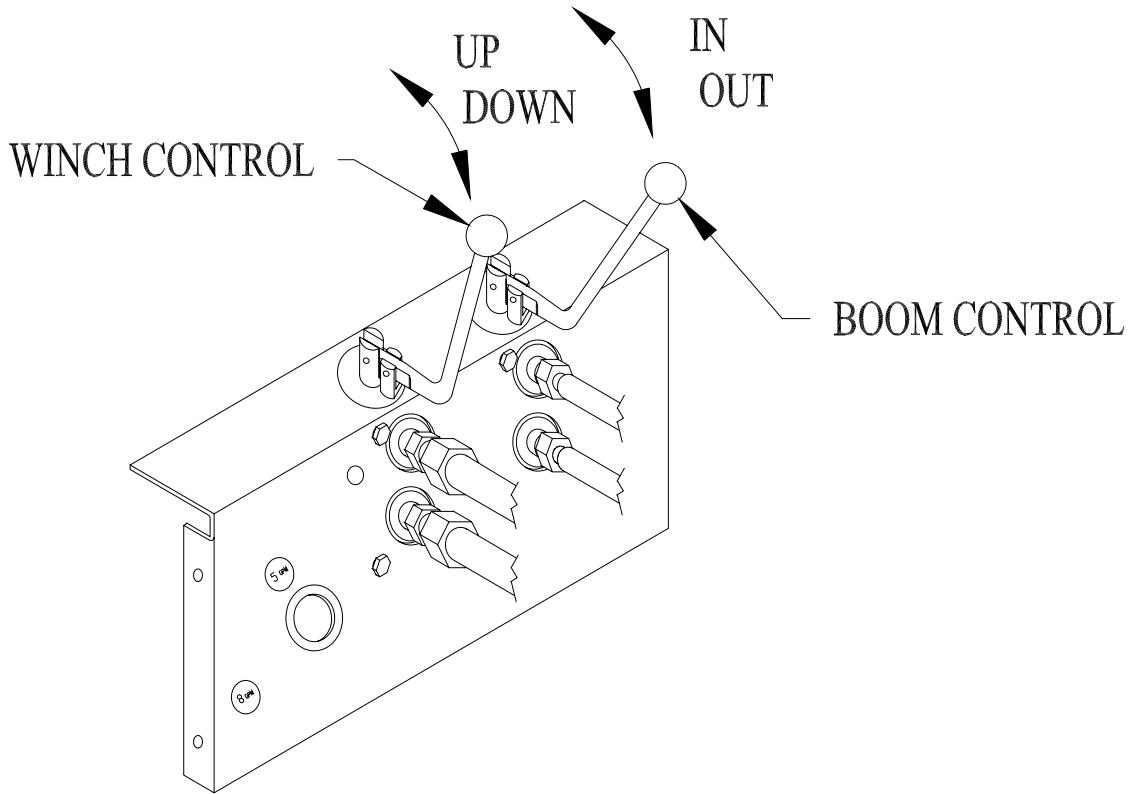

Figure 4-2.
HydraPak With Fixed 6 GPM Control

3. The hoist operator must remain behind the operator fence when operating the hoist. All personnel must be protected by OSHA compliant fall protection when handling loads at the roof edge. See Figure 4-3.



WARNING:
ALL PERSONNEL SHALL BE PROTECTED BY OSHA COMPLIANT FALL PROTECTION.



WARNING:
PERSONNEL MUST NEVER SECURE A LIFE LINE TO THE HOIST FRAME STRUCTURE.

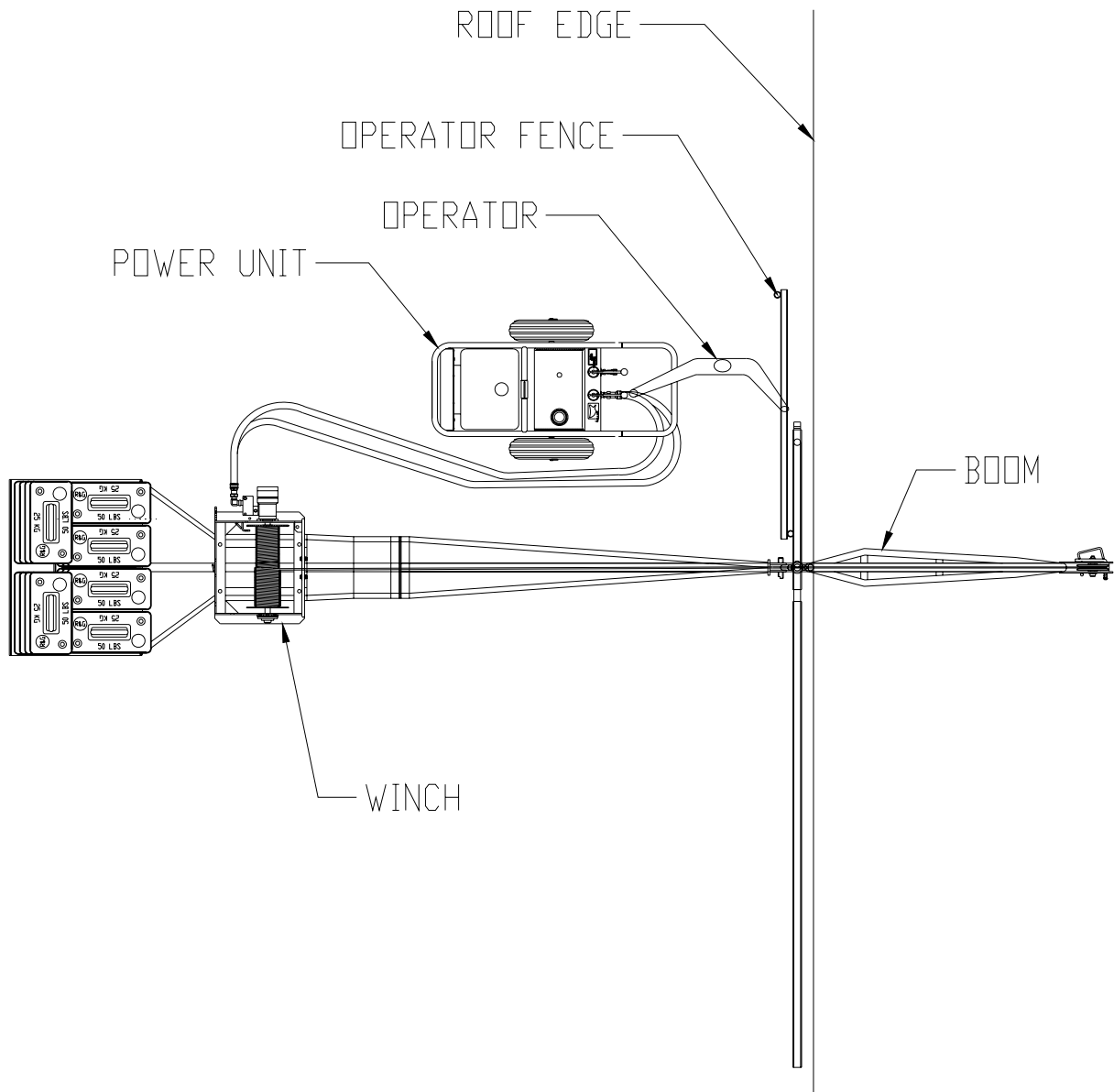

Figure 4-3.
Typical HydraPak/Hoist Positioning

4. With control levers in neutral, start the HydraPak and allow to warm up.
5. Put the throttle in the middle position when starting and slow when stopping the engine. This provides a warming and cooling period. Know how to stop your HydraPak quickly in case of emergency. Consult the engine manual for detailed operation of engine controls.
6. Pull winch control lever up to raise a load and down to lower a load. See Figures 4-1 and 4-2. Never allow anybody to ride on the hoist. Make a few “dry runs” (without load, but **with** ballast) to become familiar with operation, controls, and power unit and to test hoisting clearance. Always maintain 10-20 pounds of wire rope tension with a cable weight. Do NOT attempt to make any equipment adjustments during operation.
7. Before lifting, secure the load from shifting and insure the safety latch on the hook is not supporting any load. Use tag lines to control all loads. Never hoist over an open doorway.



WARNING:
AVOID SIDE LOADS, SHOCK LOADS, AND SUDDEN STOPS.



WARNING:
KEEP OUT FROM UNDER A RAISED LOAD.

8. Use the boom control lever shown in Figures 4-1 and 4-2 to swing the boom 135° to load or unload material on the roof deck where you are working.
9. When lowering the load, gradually decelerate the lowering speed as it nears the ground.



CAUTION:
THE WINCH DRUM MUST ALWAYS HAVE AT LEAST THREE TURNS OF WIRE ROPE WHEN THE LOAD IS AT THE LOWEST POINT OF TRAVEL.

4.3 HAND SIGNALS

Hand signals have an important advantage over voice commands in high noise environments. Using hand signals ensures proper synchronization of actions between the roof personnel and the ground operator and can give immediate warning of a potentially unsafe condition. All persons must be familiar with hand signals. Use the hand signals as shown in Figures 4-4 through 4-8.



WARNING:
A GOOD LINE OF COMMUNICATION MUST BE MAINTAINED BETWEEN THE HOIST OPERATOR AND ALL PERSONNEL FOR SAFETY. AT THE MINIMUM, ALL CREW MEMBERS MUST BE FAMILIAR WITH HAND SIGNALS.



With forearm vertical, forefinger pointing up, move hand in small horizontal circle.

Figure 4-4.
“Hoist” Signal

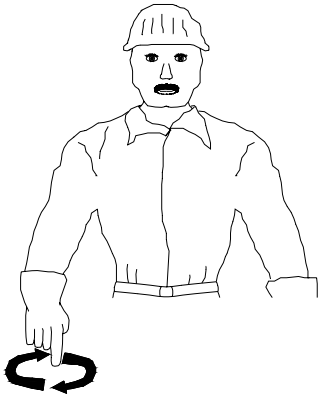

With arm extended downward, forefinger pointing down, move hand in small horizontal circle.

Figure 4-5.
“Lower” Signal

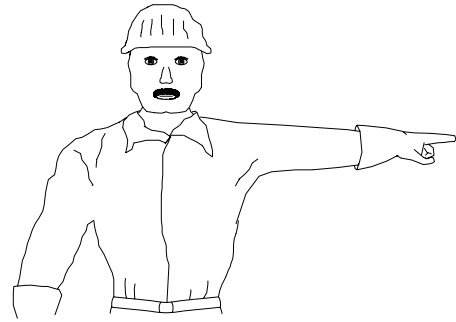

Arm extended, palm down, hold position rigidly

Figure 4-6.
“Stop” Signal

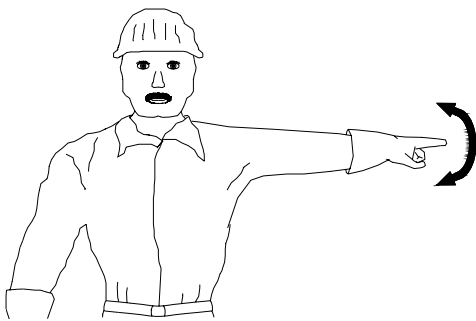

Arm extended, palm down, place other hand motionless in front of hand giving the signal. (Hoist Slowly shown as example.)

Figure 4-7.
“Emergency Stop” Signal

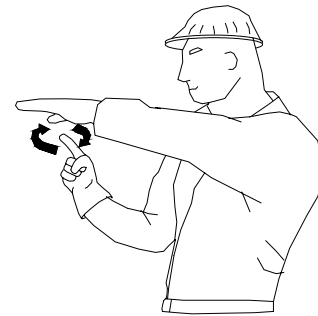

Use one hand to give any motion signal and hand motionless in front of hand giving the signal. (Hoist Slowly shown as example.)

Figure 4-8.
”Move Slowly” Signal

4.4 PREPARING HOIST FOR SHUTDOWN

At the end of operation, secure the equipment to prevent unauthorized use. **Never** assume you will find the equipment in the same condition that you left it. Proceed as follows:

1. Swing the Boom to the 135° position over rooftop. Ensure that all lifting tension has been removed from the wire rope.
2. Shut off HydraPak and take necessary action to prevent its unauthorized use.
3. If the hoist is being permanently disassembled, at the end of a project for example, follow the detailed disassembly procedures in Chapter 5.

5 DISASSEMBLY

5.1 PRIOR TO DISASSEMBLY



WARNING:

ONLY TRAINED PERSONNEL SHALL DISASSEMBLE THE HOIST. A TRAINED PERSON IS ONE WHO HAS READ AND THOROUGHLY UNDERSTANDS THIS INSTRUCTION MANUAL AND RELATED EQUIPMENT MANUALS AND, THROUGH TRAINING AND EXPERIENCE, HAS SHOWN KNOWLEDGE REGARDING THE SAFE OPERATIONAL PROCEDURES.

5.2 REWINDING THE WIRE ROPE

1. Swing boom to the 135° position over rooftop.
2. Ensure that all lifting tension has been removed from the wire rope.
3. Using a step ladder (not an extension ladder) with OSHA compliant fall protection, unlock the cable keeper at the top of the boom by pulling out on the handle and rotating it in the direction shown in Figure 3-2. Remove the cable block (if used in two part of line applications), shackle and safety hook. Remove wire rope between cable keeper and sheave. Lock cable keeper in position by pulling out on handle and rotating handle in the direction shown in Figure 3-2. This handle is spring loaded and has to be pulled out to operate.



WARNING:

NEVER CLIMB ON THE FRAME FOR ANY REASON. AN ACCIDENT WHILE DOING THIS CAN CAUSE DEATH OR SERIOUS PERSONAL INJURY.

4. Tie a safety line at least 5 feet long to the wire rope end to prevent any accidental drawing of the operator's hand into the winch during rewinding.
5. Start the HydraPak and put it in idle at 5 gpm, if applicable. "Feather" the valve to start the winch. Operate the winch to rewind enough wire rope to bring the wire rope end to near the top of the boom. Ensure that the wire rope is rewinding evenly on the drum.
6. "Feather" the HydraPak valve to rewind the wire rope through the pivot sheave and then the guide on the winch. As the wire rope end approaches the drum, handle the wire rope only by the safety line described in Step 4.
7. When the wire rope end reaches the winch, release winch control lever, shut off the HydraPak and remove the safety line. Safely anchor the wire rope end for convenient access.

5.3 REMOVING THE WINCH

1. Disconnect the hydraulic hoses between the winch and HydraPak.
2. Remove the two pins and hairpins securing the winch to the counterweight leg. Then remove the winch from its mounting position.

5.4 REMOVING PARTS FROM DECK

Complete the dismantling of the hoist by disassembling the frame as described in the hoist manual. When removing any parts from the deck, observe the following safety rules:

1. Use a hoist beam, swing beam or freight elevator to lower the disassembled parts of the hoist to the ground.
2. Safely secure the hoist parts on the transporting medium without overloading before lowering to the ground.

3. If a freight elevator or other transporting medium is not available to lower the HydraPak to the ground, it may be done using the hand winch as described in Section 5.5.

5.5 LOWERING THE POWER UNIT TO THE GROUND USING THE OPTIONAL HAND WINCH



WARNING:

THE HAND WINCH IS NOT A MATERIAL HOIST. USE ONLY FOR RAISING AND LOWERING THE HYDRAPAK. DO NOT HOIST OR LOWER CONSTRUCTION OR DEMOLITION MATERIAL.



WARNING:

EITHER 1000 LBS. (ONTARIO OHSA: 570 KG.) FOR AN HS1000 HOIST OR 2000 LBS. (ONTARIO OHSA: 1140 KG.) FOR AN HS2000 HOIST OF REIMANN & GEORGER CORPORATION APPROVED BALLAST BLOCKS MUST BE SECURED PROPERLY IN THE LOWER COUNTERWEIGHT BASKET WITH ROPE BEFORE LOWERING THE HYDRAPAK.



WARNING:

NEVER USE HUMAN BEINGS AS COUNTERWEIGHT.

1. Ensure the cylinder has been removed as described in the hoist manual.
2. Ensure that the boom is in the 135° position. Install a tether line to the boom for swinging it into the hoisting position for lowering the HydraPak to the ground.
3. Mount the hand winch on the hoist and reeve the wire rope as described in Section 3.4 of Chapter 3.
4. Connect the wire rope to the lifting eye on the HydraPak. Ensure the hook fastens securely to the lifting eye.
5. Attach a tag line to the HydraPak frame to control swaying during the lowering of the power unit.
6. The operator on the roof cranks the winch to raise the HydraPak enough to suspend it over the rooftop.



WARNING:

ALWAYS STAND CLEAR OF THE SUSPENDED UNIT.

7. Use the Boom tether to swing the HydraPak into the hoisting position over the roof edge.
8. The roof operator lowers the HydraPak to the ground by cranking the winch in the opposite direction.
9. After the HydraPak is on the ground with no remaining wire rope tension, remove the winch from the hoist.

6 INSPECTION AND MAINTENANCE

6.1 GENERAL MAINTENANCE RULES

Maintenance information for the associated HydraPak and hoist is in the respective specific manuals for these units.

1. Proper maintenance of the winch and related equipment consists of adhering to all the guidelines given in this chapter and in the Pre-Hoisting Checklist in the front of this manual. Proper maintenance is required to maintain the system in good condition, which is defined as each part being free of rust or other corrosion, bends, breaks, or other defects.
2. Review and follow all the safety rules before attempting any maintenance.
3. Only authorized personnel should be allowed in the maintenance area. Authorized personnel are the trained people as defined below and their supervision. Place barricades or secure the area in such a manner that if there was an equipment failure, no personnel would be injured.
4. Repairs must be made only by trained personnel. A trained person is one who has read and thoroughly understands this instruction manual and related equipment manuals and, through training and experience, has shown knowledge regarding the safe operational and maintenance procedures.
5. All authorized maintenance personnel should be wearing, as a minimum, hard hats, safety glasses and safety shoes.



WARNING:

WEAR HEAVY LEATHER GLOVES WHEN HANDLING WIRE ROPE.

6. Do not weld or otherwise modify the winch or any other part of the hoist. Such alterations may weaken the structural integrity of the winch or hoist and invalidate your warranty.



WARNING:

DO NOT ATTEMPT ANY HOISTING DURING ANY ERECTION, MAINTENANCE, OR REPAIR PROCEDURES.



WARNING:

SHUT DOWN AND LOCK OUT THE HYDRAPAK TO PREVENT ACCIDENTAL STARTUP. RELIEVE OR RENDER SAFE ALL THE POTENTIALLY HAZARDOUS ENERGY.



WARNING:

THE LOAD MUST BE AT THE LOWEST POSITION WHEN WORKING ON ANY PART OF THE HOIST.



WARNING:

DO NOT ADJUST OR REMOVE HYDRAULIC COMPONENTS, LINES, OR FITTINGS WHILE THE HYDRAPAK IS RUNNING OR WHENEVER THE HYDRAULIC FLUID IS HOT.



WARNING:

LIQUID UNDER HIGH PRESSURE CAN PIERCE THE SKIN, CAUSING DEATH OR SERIOUS INJURY. IN CASE OF INJURY, GET IMMEDIATE MEDICAL ATTENTION.

7. It is important that all the maintenance procedures outlined in the Pre-Hoisting Checklist in the front of this manual be done daily. Details on inspecting the wire rope are given in Section 6.2. All broken, worn or defective parts must be repaired or replaced before startup.

6.2 WIRE ROPE INSPECTION PROCEDURE

Inspect the wire rope prior to each use and at least daily for signs of wear and damage. Inspect the entire wire rope working length. Thoroughly inspect the rope sections that pass over sheaves or drums, or that make opposing turns. Inspect wire rope and end attachments carefully. While inspecting, examine sheaves, guards, guides, drums, flanges, and other surfaces contacting wire rope during operation. Correct any condition harming the rope in use or other damage or worn surfaces at this time.

Remove or replace immediately wire rope with one or more of the following defects:

1. Corrosion
2. Broken wires:
 - (a) One or more valley breaks. A valley break is a wire break occurring in the valley between two adjacent strands.
 - (b) Six randomly distributed broken wires in one rope lay. A rope lay is the length of rope along which one strand makes a complete revolution around the rope. See Figure 6-1. Keeping the rope clean and wound evenly on the drum will increase its life and efficiency.

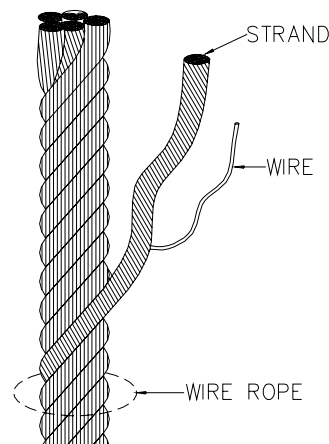

Figure 6-1.
Wire Rope Components

3. Abrasion: Scrubbing, flattening or peening causing loss of more than one-third of the original diameter of the outside wires.
4. Kinking: Severe kinking, crushing, bird caging or other damage causing distortion of the rope structure. Bird caging is a bulging in the wire rope caused by the individual wires becoming untwisted. This untwisting of individual wires is usually caused by impact loading on the wire rope (such as a sudden stop).
5. Heat damage: Evidence of any heat damage caused by a torch or by contact with electrical wires.
6. Reduction of more than 1/64 inch from the nominal 1/4-inch diameter wire rope. Marked reduction in diameter indicates core deterioration.

7 TROUBLESHOOTING

The following chart is intended to assist with troubleshooting the HydraWinch. While not all inclusive, the chart outlines the most common causes of a problem and the recommended course of action.

Troubleshooting guides for the associated HydraPak and swing hoist are in the instruction manuals specifically for these units.

| SYMPTOM | CAUSE AND CORRECTIVE ACTION |
|--|--|
| Winch operating slowly or not at all—HydraPak engine operating normally. | <p>Hoses from HydraPak to winch leaking fluid in line or have a poor connection.</p> <p>HydraPak hydraulic system malfunctioning—refer to Troubleshooting chapter in HydraPak manual.</p> |
| Load drifts down. | Wire rope is coming off bottom of drum instead of top. |
| Hoist won't lift load or is lifting it very slowly. | <p>Engine speed too slow—increase throttling.</p> <p>Hydraulic oil flow too high for load—reduce flow from 8 gpm to 5 gpm.</p> <p>Load not moving freely—check for block or wire rope malfunctions.</p> <p>Single line operation being attempted for more than a 1000 pound load—use double line operation for loads up to 2000 pounds with an HS2000 hoist.</p> <p>Problem with HydraPak hydraulics or related engine operation—refer to Troubleshooting chapter of the HydraPak manual for details.</p> <p>Too much wire rope on drum—hoisting capacity decreases as wire rope diameter increases.</p> <p>Hoist attempting to lift more than stated capacity of unit—check capacity rating and reduce load weight as needed.</p> |

8 PARTS LISTS

The following parts lists apply to the HydraWinch units only. The parts lists for the associated HS1000, HS2000, and HydraPak units are in the separate manuals for these items. Each item number on these parts lists can be matched with the item number shown on the Figure 8-1 assembly drawing.

8.1 HW1000S HYDRAWINCH

| REF # | PART # | QTY | DESCRIPTION |
|-------|---------|-----|------------------------------|
| 1 | 1000785 | 1 | WINCH FRAME |
| 2 | 1000790 | 1 | DRUM GUARD |
| 3 | 6000759 | 1 | GAGE PORT ADAPTER |
| 4 | 1000981 | 1 | LOCKING ARM |
| 5 | 1006589 | 1 | VALVE GUARD |
| 6 | 6010756 | 1 | MOTOR LOCK VALVE |
| 7 | 6000919 | 1 | COUPLING FEMALE |
| 8 | 1000787 | 1 | PILLOW BLOCK MOUNT |
| 9 | 5100925 | 1 | PILLOW BLOCK BEARING |
| 10 | 1005309 | 1 | WINCH DRUM GUARD |
| 11 | 6000920 | 1 | COUPLING MALE |
| 12 | 1000984 | 1 | DRUM ASSEMBLY |
| 13 | 7304346 | 1 | WIRE ROPE 1/4" X 150 FT. |
| 14 | 7300348 | 1 | SHACKLE 1 TON |
| 15 | 7314700 | 1 | SWIVEL HOOK WITH LATCH |
| 16 | 1004157 | 1 | HYDRAULIC TUBE |
| 17 | 1000978 | 1 | SPROCKET GUARD |
| 18 | 1004848 | 1 | SPRING MOUNT |
| 19 | 6500816 | 1 | HYDRAULIC MOTOR |
| 20 | 0810962 | 1 | HYDRAULIC RAM |
| 21 | 5800961 | 1 | SPRING |
| 22 | 5806387 | 2 | JAM NUT |
| 23 | 1604760 | 1 | PRESSURE TEST KIT (OPTIONAL) |
| | 7400896 | 1 | SEAL KIT FOR RAM (OPTIONAL) |
| 24 | 5000100 | 1 | LOCKING ARM PIVOT BOLT |
| 25 | 1004155 | 1 | SPRING STUD |

8.2 HW2000S HYDRAWINCH

| REF # | PART # | QTY | DESCRIPTION |
|-------|---------|-----|------------------------------|
| 1 | 1000785 | 1 | WINCH FRAME |
| 2 | 1000790 | 1 | DRUM GUARD |
| 3 | 6000759 | 1 | GAGE PORT ADAPTER |
| 4 | 1000981 | 1 | LOCKING ARM |
| 5 | 1006589 | 1 | VALVE GUARD |
| 6 | 6010756 | 1 | MOTOR LOCK VALVE |
| 7 | 6000919 | 1 | COUPLING FEMALE |
| 8 | 1000787 | 1 | PILLOW BLOCK MOUNT |
| 9 | 5100925 | 1 | PILLOW BLOCK BEARING |
| 10 | 1005309 | 1 | WINCH DRUM GUARD |
| 11 | 6000920 | 1 | COUPLING MALE |
| 12 | 1000984 | 1 | DRUM ASSEMBLY |
| 13 | 7304350 | 1 | WIRE ROPE 1/4" X 200 FT. |
| 14 | 7300348 | 1 | SHACKLE 1 TON |
| 15 | 7314700 | 1 | SWIVEL HOOK WITH LATCH |
| 16 | 1004157 | 1 | HYDRAULIC TUBE |
| 17 | 1000978 | 1 | SPROCKET GUARD |
| 18 | 1004848 | 1 | SPRING MOUNT |
| 19 | 6500763 | 1 | HYDRAULIC MOTOR |
| 20 | 6000962 | 1 | HYDRAULIC RAM |
| 21 | 5800961 | 1 | SPRING |
| 22 | 5806387 | 2 | JAM NUT |
| 23 | 1604760 | 1 | PRESSURE TEST KIT (OPTIONAL) |
| | 7400896 | 1 | SEAL KIT FOR RAM (OPTIONAL) |
| 24 | 5000100 | 1 | LOCKING ARM PIVOT BOLT |
| 25 | 1004155 | 1 | SPRING STUD |

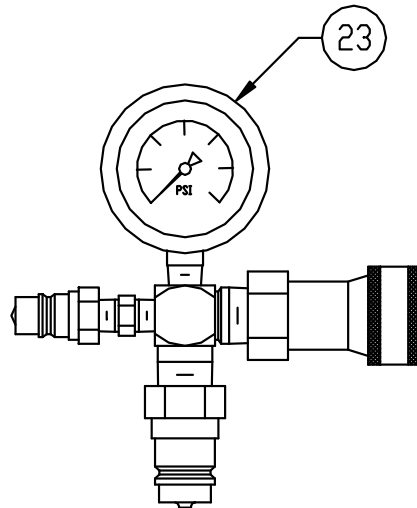

PRESSURE TEST KIT

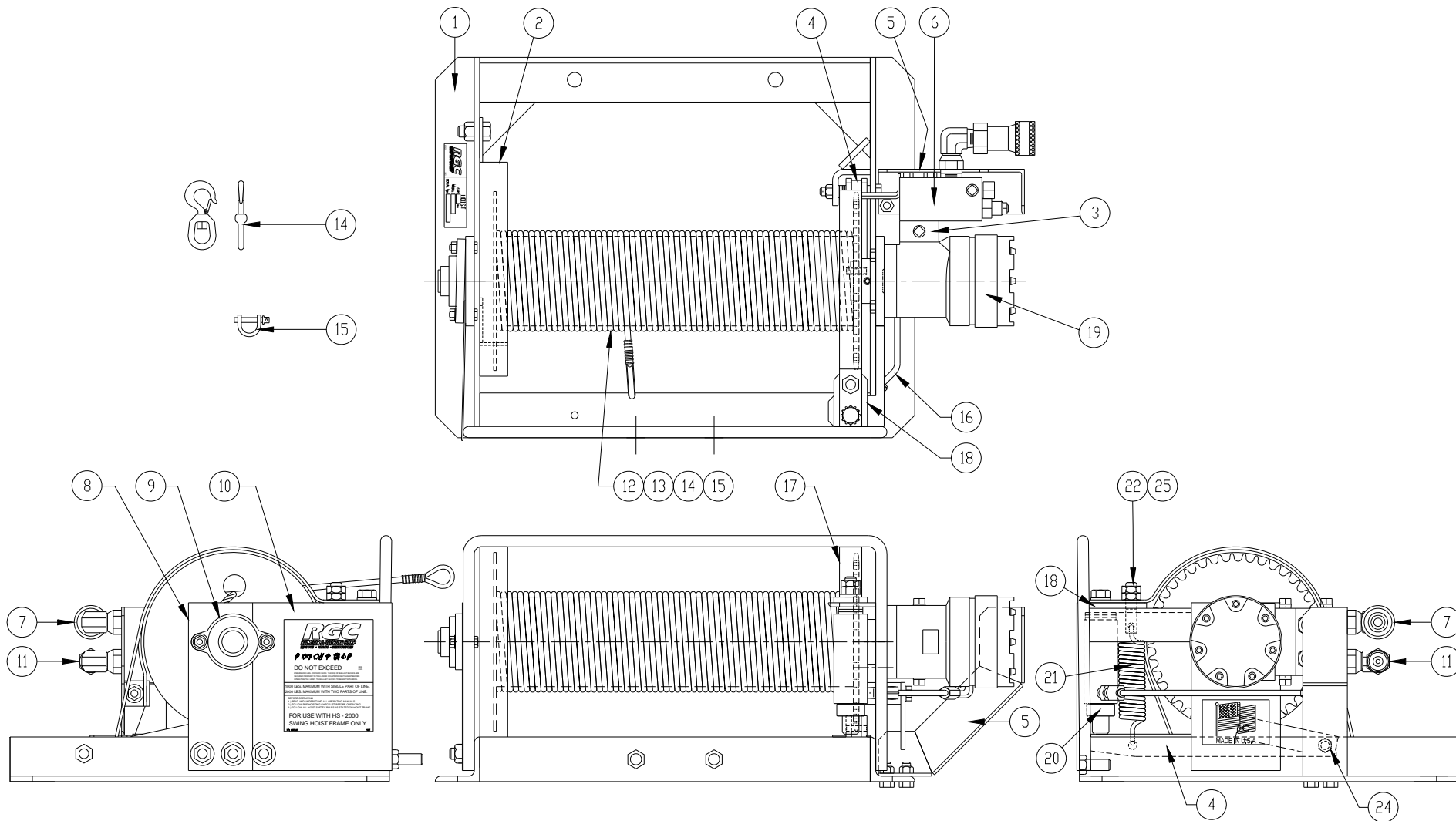

Figure 8-1.
HydraWinch Assembly Drawing

LIMITED PRODUCT WARRANTY

**Reimann & Georger Corporation
Hoisting and Construction Products**

A. LIMITED WARRANTY

Reimann & Georger Corporation (the "Manufacturer") warrants to the original purchaser (the "Buyer") that all Reimann & Georger Hoisting and Construction products shall be free of defects in material and workmanship for a period of one (1) year from date of original purchase.

B. MANUFACTURER'S OBLIGATIONS

The Manufacturer's sole obligation under this Limited Warranty is the repair or, at the Manufacturer's discretion, the replacement of parts found to be defective. Parts and equipment must have authorization from the Manufacturer prior to return to the Manufacturer or repair by an authorized service person. Costs of transportation and other expenses connected with replacing or repairing parts are not covered under this Limited Warranty.

C. PARTS MANUFACTURED BY OTHERS

This Limited Warranty does not cover any parts manufactured by others. Such parts are subject to the warranty, if any, of their respective manufacturers, and are to be repaired only by a respective authorized service person for such parts. The Manufacturer shall have no obligation to undertake repairs of parts manufactured by others.

D. NO SPECIAL, INCIDENTAL, OR CONSEQUENTIAL DAMAGES

IN NO EVENT SHALL THE MANUFACTURER BE LIABLE TO THE BUYER OR ANY OTHER PERSON FOR ANY INDIRECT, SPECIAL, INCIDENTAL OR CONSEQUENTIAL LOSSES OR DAMAGES CONNECTED WITH THE USE OF THE PRODUCT UNDER THIS LIMITED WARRANTY. SUCH DAMAGES FOR WHICH THE MANUFACTURER SHALL NOT BE RESPONSIBLE INCLUDE, BUT ARE NOT LIMITED TO, LOST TIME AND CONVENIENCE, LOSS OF USE OF THE PRODUCT, THE COST OF A PRODUCT RENTAL, COSTS OF GASOLINE, TELEPHONE, TRAVEL, OR LODGING, THE LOSS OF PERSONAL OR COMMERCIAL PROPERTY, AND THE LOSS OF REVENUE.

E. NO LIABILITY IN EXCESS OF PURCHASE PRICE

IN NO EVENT SHALL THE MANUFACTURER'S OBLIGATIONS UNDER THIS LIMITED WARRANTY EXCEED THE PURCHASE PRICE OF THE PRODUCT.

F. NO EXTENSION OF STATUTE OF LIMITATIONS

ANY REPAIRS PERFORMED UNDER THIS WARRANTY SHALL NOT IN ANY WAY EXTEND THE STATUTES OF LIMITATIONS FOR CLAIMS UNDER THIS LIMITED WARRANTY.

G. WAIVER OF OTHER WARRANTIES

THE EXPRESS WARRANTIES SET FORTH IN THIS LIMITED WARRANTY ARE IN LIEU OF AND EXCLUDE ANY AND ALL OTHER WARRANTIES, EXPRESS OR IMPLIED, INCLUDING, BUT NOT LIMITED TO, THE IMPLIED WARRANTIES OR MERCHANTABILITY AND FITNESS FOR A PARTICULAR PURPOSE.

H. PROCEDURE FOR WARRANTY PERFORMANCE

If the product fails to perform to the Manufacturer's specifications, the Buyer must provide the Manufacturer with the applicable model and serial numbers, the date of purchase, and the nature of the problem.

I. ADDITIONAL EXCLUSIONS FROM THIS LIMITED WARRANTY. THIS LIMITED WARRANTY DOES NOT COVER ANY OF THE FOLLOWING:

1. Equipment which has been abused, damaged, used beyond rated capacity, or repaired by persons other than authorized service personnel.
2. Damage caused by acts of God which include, but are not limited to, hailstorms, windstorms, tornadoes, sandstorms, lightning, floods, and earthquakes.
3. Damage under conditions caused by fire or accident, by abuse or by negligence of the user or any other person other than the Manufacturer, by improper installation, by misuse, by incorrect operation, by "normal wear and tear", by improper adjustment or alteration, by alterations not completed by authorized service personnel, or by failure of product parts from such alterations.
4. Costs of repairing damage caused by poor or improper maintenance, costs of normally scheduled maintenance, or the cost of replacing any parts unless done as the result of an authorized repair covered by the one (1) year Limited Warranty.
5. Costs of modifying the product in any way once delivered to the Buyer, even if such modifications were added as a production change on other products made after the Buyer's product was built.

J. NO AUTHORITY TO ALTER THIS LIMITED WARRANTY

No agent, representative, or distributor of the Manufacturer has any authority to alter the terms of this Limited Warranty in any way.