

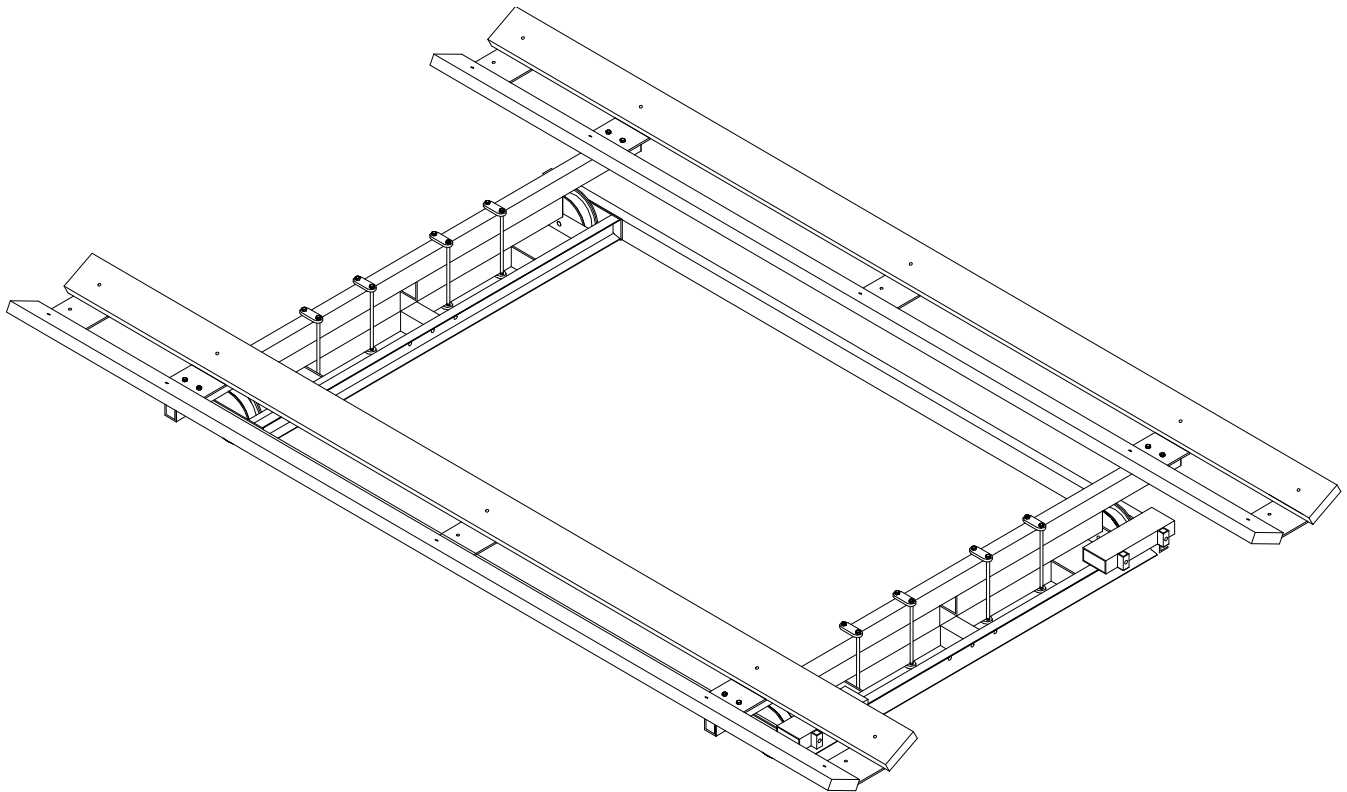

AR4000 & AR6000 PONTOON & TRITON CRADLE SUPPORTS



REIMANN & GEORGER CORPORATION
MARINE PRODUCTS
P/N 6112200

BUFFALO, NY
08/02/10

1. INSTALLATION

1.1 PRE-INSTALLATION CHECKS

1. Do not assemble the pontoon cradle support brackets if any part shows any sign of damage.
2. All boat berthing accessories such as pontoon brackets, pivoting bunks, and guide ons, must be commercially manufactured, have a rated load capacity equal to that of the railway, and be properly maintained and installed. Consult the manufacturer's instructions provided for these accessories.
3. This product has been supplied with stainless steel hardware to protect against a harsh marine environment and provide outstanding performance. Due to the chemistry and surface condition of stainless steel, there is a natural tendency for the hardware to "gall, lock up, or seize" during assembly. To prevent this from occurring, it is **highly recommended** that the anti-seize supplied in the hardware bag be applied to the mating surfaces of all stainless steel fasteners before assembly. Lubricants containing molybdenum disulfide, graphite, mica or talc may also be used.



CAUTION:

DO NOT EXCEED THE MAXIMUM TORQUE RATING ON ALL BOLTS OF 20 FT-LBS.



WARNING:

FAILURE TO APPLY A SUITABLE LUBRICANT TO THE MATING SURFACES OF STAINLESS STEEL THREADED FASTENERS MAY CAUSE GALLING AND/OR SEIZING OF ASSEMBLY.

4. During installation, the following precautions must be observed when lifting any part of this equipment:
 - a. Be sure of your footing.
 - b. Bend your knees and lift with your legs.
 - c. Hold the equipment section close to your body when lifting.

The part reference numbers and letters used in the subassembly drawings of sections 3.2 through 3.10 are the same as those listed in the parts lists of Chapter 6.

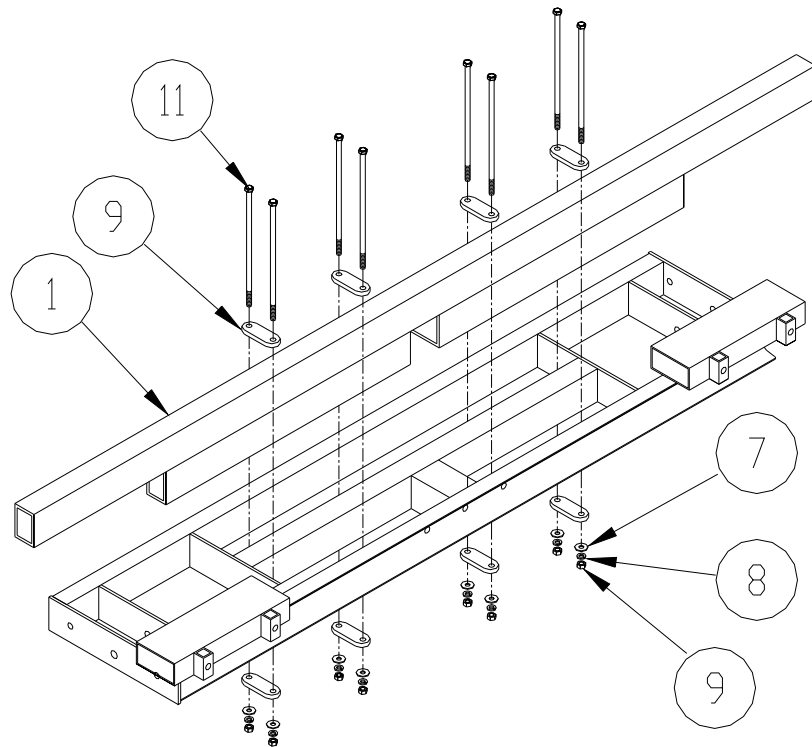

Figure 1.
Cradle Support Weldment Assembly

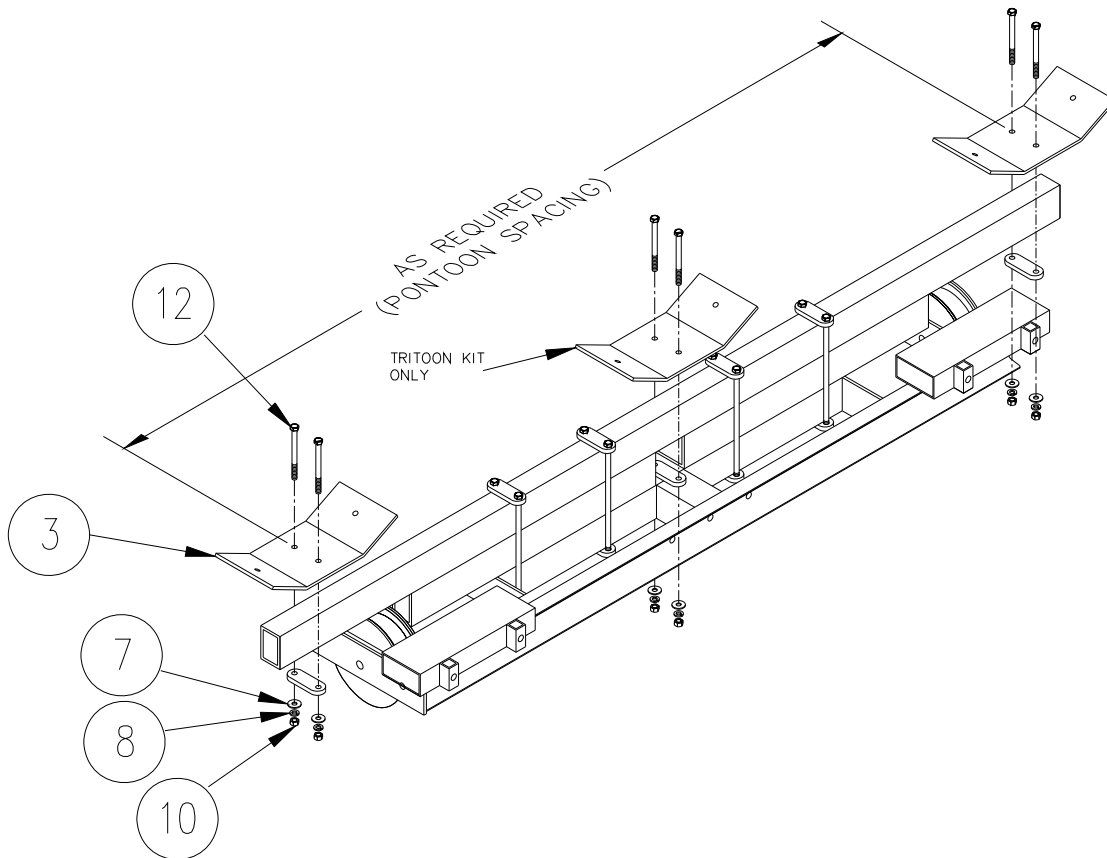

Figure 2.
Mount Pontoon / Tritoon Cradles to Carriage

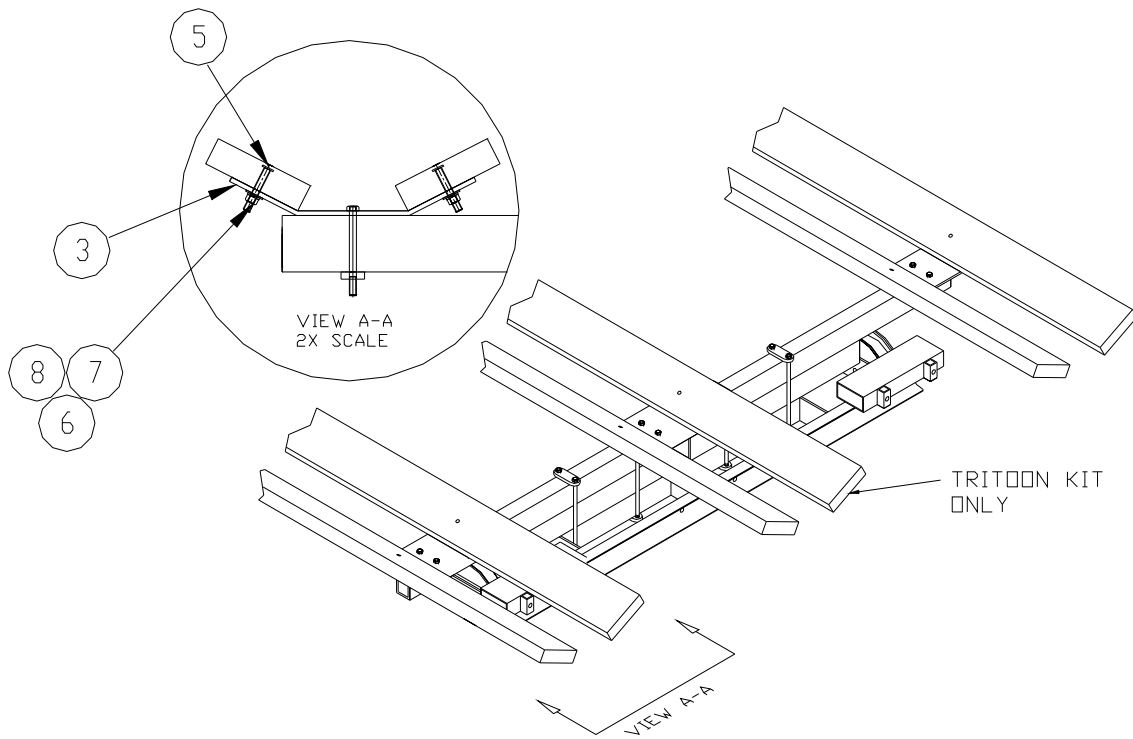

Figure 3.
Mount Bunk to 4-Hole Support Plates

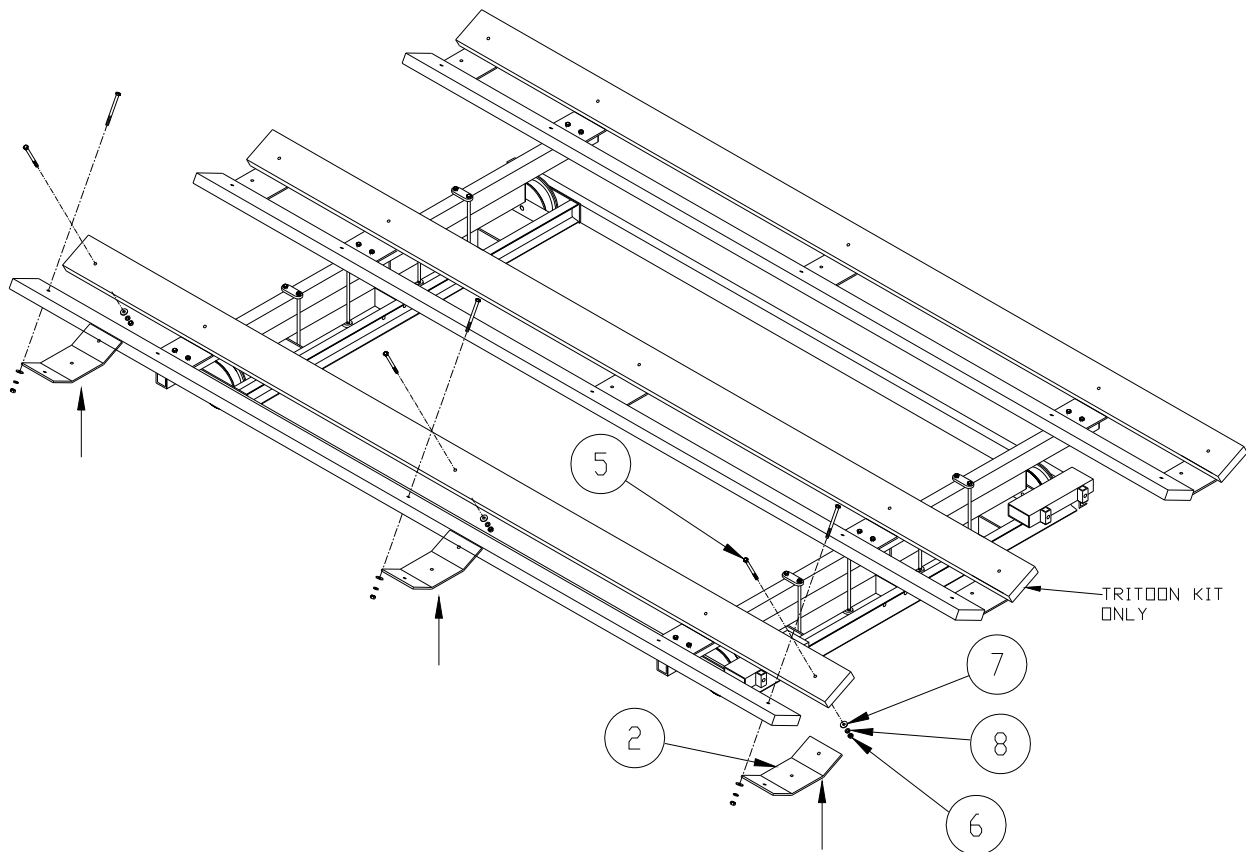

Figure 4.
Mount Bunk Support Plates 3-Hole

2. PARTS LISTS

Each reference number or letter in the following AR6K Railway parts lists can be matched with the reference number or letter referred to in both the text and illustrations of Chapter 3, Installation and Setup.



WARNING:

FAILURE TO APPLY A SUITABLE LUBRICANT TO THE MATING SURFACES OF STAINLESS STEEL THREADED FASTENERS MAY CAUSE GALLING AND/OR SEIZING OF ASSEMBLY.

3536165 AR4K PONTOON CRADLE SUPPORTS

REF #	PART #	QTY	DESCRIPTION
1	3536120	2	PONTOON CRADLE SUPPORT WELDMENT
2	3603390	6	PONT BUNK SUPPORT PLATE 3-HOLE 6 X 14
3	3603391	4	PONT BUNK SUPPORT PLATE 4-HOLE 6 X 14
4	3608049	4	LOWER WOOD BUMPER 14"
5	5896323	28	3/8-16 X 2-1/2 CARR BOLT
6	5896377	44	HEX NUT 3/8-16 SS
7	5896406	52	WASHER FLAT SAE 3/8" SS
8	5806243	52	WASHER SPLIT LOCK 3/8" SS
9	3603835	20	2-HOLE PLATE 3"
10	5803638	8	NUT HEX SILICONE BRONZE 3/8"
11	5896272	16	HHCS 3/8-16 X 10-1/2 SS
12	5896262	8	HHCS 3/8-16 X 4-1/2

3536200 AR6K PONTOON CRADLE SUPPORTS

REF #	PART #	QTY	DESCRIPTION
1	3536120	2	PONTOON CRADLE SUPPORT WELDMENT
2	3603389	6	PONT BUNK SUPPORT PLATE 3-HOLE 10 X 14
3	3603388	4	PONT BUNK SUPPORT PLATE 4-HOLE 10 X 14
4	3608049	4	LOWER WOOD BUMPER 14"
5	5896323	28	3/8-16 X 2-1/2 CARR BOLT
6	5896377	44	HEX NUT 3/8-16 SS
7	5896406	52	WASHER FLAT SAE 3/8" SS
8	5806243	52	WASHER SPLIT LOCK 3/8" SS
9	3603835	20	2-HOLE PLATE 3"
10	5803638	8	NUT HEX SILICONE BRONZE 3/8"
11	5896275	16	HHCS 3/8-16 X 12 SS
12	5896262	8	HHCS 3/8-16 X 4-1/2

3536170 AR4K TRITOON CRADLE SUPPORTS

REF #	PART #	QTY	DESCRIPTION
1	3536120	2	PONTOON CRADLE SUPPORT WELDMENT
2	3603390	9	PONT BUNK SUPPORT PLATE 3-HOLE 6 X 14
3	3603391	6	PONT BUNK SUPPORT PLATE 4-HOLE 6 X 14
4	3608049	4	LOWER WOOD BUMPER 14"
5	5896323	38	3/8-16 X 2-1/2 CARR BOLT
6	5896377	54	HEX NUT 3/8-16 SS
7	5896406	66	WASHER FLAT SAE 3/8" SS
8	5806243	66	WASHER SPLIT LOCK 3/8" SS
9	3603835	22	2-HOLE PLATE 3"
10	5803638	12	NUT HEX SILICONE BRONZE 3/8"
11	5896272	16	HHCS 3/8-16 X 10-1/2 SS
12	5896262	12	HHCS 3/8-16 X 4-1/2

3536205 AR6K TRITOON CRADLE SUPPORTS

REF #	PART #	QTY	DESCRIPTION
1	3536120	2	PONTOON CRADLE SUPPORT WELDMENT
2	3603389	9	PONT BUNK SUPPORT PLATE 3-HOLE 10 X 14
3	3603388	6	PONT BUNK SUPPORT PLATE 4-HOLE 10 X 14
4	3608049	4	LOWER WOOD BUMPER 14"
5	5896323	38	3/8-16 X 2-1/2 CARR BOLT
6	5896377	54	HEX NUT 3/8-16 SS
7	5896406	66	WASHER FLAT SAE 3/8" SS
8	5806243	66	WASHER SPLIT LOCK 3/8" SS
9	3603835	22	2-HOLE PLATE 3"
10	5803638	12	NUT HEX SILICONE BRONZE 3/8"
11	5896275	16	HHCS 3/8-16 X 12 SS
12	5896262	12	HHCS 3/8-16 X 4-1/2