

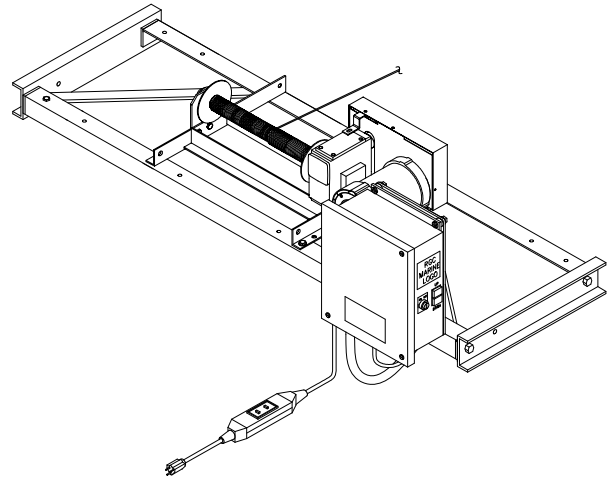

RPD STD & HD MANUAL & RC INSTRUCTIONS

SWITCH CONTROL

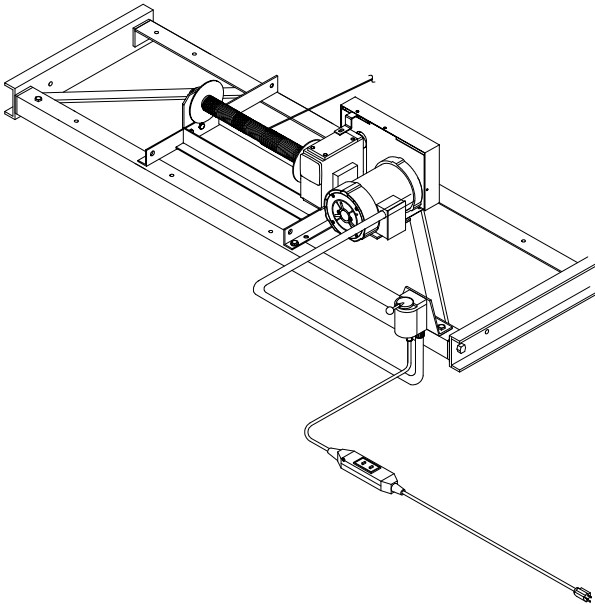

REMOTE CONTROL

REIMANN & GEORGER CORPORATION
MARINE PRODUCTS
P/N 6112007

BUFFALO, NY
9/09/11

TABLE OF CONTENTS

CHAPTER	TITLE	PAGE
1	SAFETY	1
1.1	Introduction	1
1.2	Safety Definitions	1
1.3	Equipment Safety Labels	1
1.4	Installation Safety	1
1.5	Operating Safety	2
1.5.1	General Safety	2
1.5.2	Safety When Raising Boat	2
1.5.3	Safety When Lowering Boat	2
2	SPECIFICATIONS	3
2.1	Technical Data	3
2.2	Motor Specifications	3
2.3	Motor Wiring	3
2.4	Nameplate and Serial Number Tag	4
2.5	Optional Equipment	4
3	INSTALLATION AND SETUP	5
3.1	Pre-Installation Checks	5
3.2	Mounting Power Drive	6
3.3	Mounting Remote Control Panel	7
3.4	Mounting Power Drive Manual Switch	8
3.5	Reeving Wire Rope to Carriage Standard Drive	9
3.6	Reeving Wire Rope to Carriage Heavy Duty Drive	11
3.7	Power Supply Connections	13
4	OPERATION	16
4.1	Testing Power Drive Operation	16
4.2	Raising and Lowering the Carriage	16
4.3	Securing Railway When Not in Use	16
4.4	Pre-Operative Checklist	17
5	INSPECTION AND MAINTENANCE	18
5.1	General Maintenance Rules	18
5.2	Wire Rope Inspection Procedure	18
5.3	Annual Inspection & Maintenance	19
5.4	Storage Procedure	20
6	TROUBLESHOOTING	21
7	PARTS LIST	23
7.1	Standard Railway Power Drive	23
7.2	Standard Railway Power Drive Remote Control	24
7.3	Heavy Duty Railway Power Drive	25
7.4	Heavy Duty Railway Power Drive Remote Control	26

LIST OF FIGURES

FIGURE	DESCRIPTION	PAGE
2.1	Typical Lift Product Nameplate	4
3.1	Mounting Power Drive	6
3.2	Mounting Remote Control.....	7
3.3	Mounting Manual Switch	8
3.4	Standard RC Power Drive Wire Rope Reeving for AR4K/BR4K Railway	9
3.5	Standard RC Power Drive Wire Rope Reeving for AR6K Railway	10
3.6	HD RC Power Drive Rope Reeving for AR4K/BR4K Railway	11
3.7	HD RC Power Drive Rope Reeving for AR6K Railway.....	12
3.8	AR Standard Beacher Railway With Remote Control Power Drive	14
3.9	AR HD Beacher Railway With Remote Control Power Drive.....	15
5.1	Wire Rope Components	19

1 SAFETY

1.1 INTRODUCTION

Your Reimann & Georger Corporation Marine Products Railway Power Drive is designed to be used with RGC Railways only and is engineered to provide reliable performance, long term economics and safety advantages no other type can match. However, like any other equipment, it can malfunction or become hazardous in the hands of an inexperienced and/or untrained user. Therefore, read this manual and your related railway manual thoroughly before operating the power drive to provide maximum safety for all operating personnel, and to get the maximum benefit from your equipment.



WARNING:

AN INSTALLED POWER DRIVE BECOMES AN INTEGRAL PART OF THE ASSOCIATED RAILWAY. THEREFORE, DO NOT USE THE POWER DRIVE TO OPERATE THE RAILWAY WITHOUT STUDYING BOTH THIS MANUAL AND THE RAILWAY MANUAL. FAILURE TO DO THIS CAN LEAD TO MISUSE OF THE DRIVE AND/OR RAILWAY WITH RESULTING DAMAGE AND/OR PERSONAL INJURY. CONTACT YOUR RGC® MARINE DEALER IF YOU HAVE ANY QUESTIONS.

1.2 SAFETY DEFINITIONS

A safety message alerts you to potential hazards that could hurt you or others or cause property damage. The safety messages or signal words for product safety signs are **DANGER**, **WARNING**, and **CAUTION**. Each safety message is preceded by a safety alert symbol and is defined as follows:

DANGER: Indicates an imminently hazardous situation which, if not avoided, **will** cause death or serious injury. This safety message is limited to the most extreme situations.

WARNING: Indicates a potentially hazardous situation which, if not avoided, **could** result in death or serious injury.

CAUTION: Indicates a potentially hazardous situation which, if not avoided, **may** result in minor or moderate injury. It may also be used to alert against unsafe practices and property-damage-only accidents.

1.3 EQUIPMENT SAFETY LABELS

These labels warn you of potential hazards that could cause injury. Read them carefully. If a label comes off or becomes illegible, contact a Reimann & Georger Corporation dealer for a free replacement.

1.4 INSTALLATION SAFETY

1. Do not install or use the power drive if it shows any signs of damage.



WARNING:

THE POWER DRIVE AND SUPPLY LINE MUST BE INSTALLED AND INSPECTED BY A CERTIFIED ELECTRICIAN IN ACCORDANCE WITH LOCAL ELECTRICAL CODES. BECAUSE WATER AND ELECTRICITY ARE POTENTIAL SAFETY HAZARDS, THIS INSTALLATION MUST INCLUDE A PROPERLY WORKING GROUND FAULT CIRCUIT INTERRUPTER. (G.F.C.I.)

2. Ensure that all bolts and nuts are fastened securely prior to operation.
3. Do not weld or otherwise modify any part of the power drive assembly. Such alterations may damage the power drive and/or the railway and void the associated warranties.

1.5 OPERATING SAFETY

1.5.1 GENERAL SAFETY

1. Before allowing anyone to operate the power drive, be sure they fully understand the proper operating procedure and the use of all controls and connections for both the power drive and the railway.
2. Completely remove any user or dealer installed locking devices before operating the power drive.
3. Do not operate the power drive and the railway under the influence of drugs, alcohol, or medication.
4. Do not exceed the rated maximum capacity of the railway. This can damage the power drive, railway and/or boat with resulting serious personal injury.
5. Never allow anyone into the boat when supported on the railway.
6. Never operate the power drive without the belt guard installed. Keep fingers and clothing clear of all moving parts of the railway and power drive.
7. Do not attempt to make any adjustments on the railway or power drive during operation.
8. Disconnect and lock out the power source when not using the power drive to prevent unauthorized use.
9. Never use the power drive or any part of the railway to hang or store any auxiliary equipment such as boating hardware.

1.5.2 SAFETY WHEN RAISING BOAT

1. The power drive wire rope must reeve from the top of the drum when pulling in the carriage.
2. Do not try to pull the boat close to the power drive. Keep it a safe distance away from the power drive.



WARNING:

THE POWER DRIVE BELT GUARD MUST BE INSTALLED BEFORE OPERATING. ALSO, ENSURE WIRE ROPE REEVES FROM TOP OF POWER DRIVE DRUM WHEN OPERATING

1.5.3 SAFETY WHEN LOWERING BOAT

1. The power drive wire rope must reeve from the top of the drum when lowering the carriage.



WARNING:

LOWER THE CARRIAGE JUST ENOUGH TO FLOAT THE BOAT. AVOID EXCESSIVE WIRE ROPE SLACK TO PREVENT TANGLING OF WIRE ROPE ON POWER DRIVE.

2 SPECIFICATIONS

2.1 TECHNICAL DATA

If your application requires the use of RGC Curve Track Sections, ensure cable rollers are installed properly to prevent the wire rope from contacting any structural components of your RGC Railway.

Ensure your RGC Railway track sections, especially suspended sections, are properly supported as specified in the instruction manual. RGC track Supports may be required.

Model	Standard	Heavy Duty
Motor	1 HP	1.5 HP
Gear Reducer	50:1	50:1
Drum Dia. Empty (in)	2	2
Drum Dia. Full (in)	2.65	3.65
Line Speed Min.	12	16
Line Speed Max.	9	17
Railway Minimum Slope	.63in/ft	.63in/ft
Railway Maximum Slope	3.21in/ft	3.21in/ft
Approximate Remote Control Range	100 FT	100 FT
3/16" Galvanized Aircraft Wire Rope	100 FT	200 FT
Approx. Shipping Weight – Power Drive		

2.2 MOTOR SPECIFICATIONS

STD

Horsepower – 1 RPM – 1725 Volts – 115 / 230 SF – 1.25
 HZ. – 60 Phase – 1 Amps – 14 / 7 SFA - 15 / 7.5

HD

Horsepower – 1.5 RPM – 1725 Volts – 115 / 230 SF – 1.0
 HZ. – 60 Phase – 1 Amps – 17.2 / 8.8 SFA - NA

2.3 MOTOR WIRING

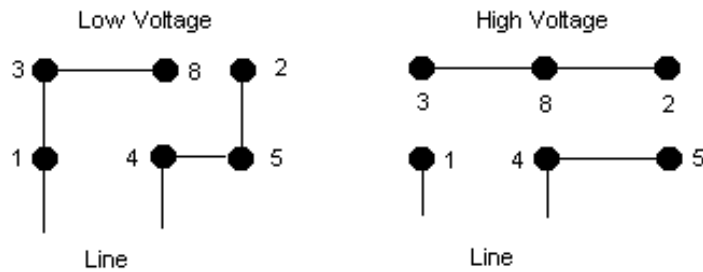

To Reverse Rotation Interchange #5 & #8

2.4 NAMEPLATE AND SERIAL NUMBER TAG

It is important to identify your Railway Power Drive completely and accurately whenever ordering spare parts or requesting assistance in service. The Power Drive has a product nameplate located on the mounting frame. The nameplate shows the model and serial numbers and capacity rating. The nameplate should appear as the sample nameplate shown in Figure 2-1. Record the serial number for future reference.

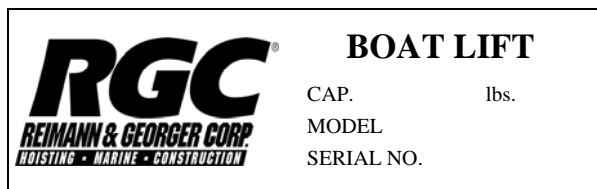

Figure 2-1.
Typical Product Nameplate

MODEL RAILWAY RC or POWER DRIVE

SERIAL NUMBER _____

MAX. LINE CAPACITY RATING _____

2.5 OPTIONAL EQUIPMENT

The following options are available which enable you to customize your Railway and Power Drive for your particular operation. Installation instructions are provided as part of each option kit.

1. **#1 Track Supports** (adj. range 18-1/2" – 27-1/2" ground to top of track) - used for railway track not supported by the ground or where track must be raised for proper operation.
2. **#2 Track Supports** (adj. range 26-1/2" – 35-1/2") - see above
3. **Pontoon Kit** – deck style or cradle design supports pontoon boat under either the deck, or under pontoon.
4. **Extra 10 Ft. Track Sections** – for installations requiring more than the standard 40 Ft. of track. Longer wire rope will be required.
5. **Curved 10 Ft. Track Sections** – required for going over seawalls and whenever there is a high degree of change between track sections
6. **Remote Control Conversion 110VAC** – converts switch operated control to remote control with a range of approximately 100 Ft.
7. **Push / Pull Power Drive** – allows rail system to be used in very shallow incline areas to pull carriage to water.
8. **Door Track Splice** – 2 Ft track section allows boathouse overhead door to fully close.

3 INSTALLATION AND SETUP

The following instructions apply to the Railway Power Drive only.

3.1 PRE-INSTALLATION CHECKS

- 1 Ensure you have received all specified parts as listed in supplied parts lists.
- 2 The Power Drive must be installed with no weight on the Railway carriage.
- 3 Ensure that the Railway has been properly installed as described in your Railway instruction manual.
- 4 Do not install or use the Power Drive if it shows any signs of damage.
- 5 Do not weld or otherwise modify any part of the Power Drive assembly. Such alterations may damage the Power Drive and / or the Railway and void the associated warranties.
- 6 Ensure the wet boat weight (total boat, fuel, all gear, etc.) does not exceed the rated capacity of railway system.
- 7 This product has been supplied with stainless steel hardware to protect against a harsh marine environment and provide outstanding performance. Due to the chemistry and surface condition of stainless steel, there is a natural tendency for the hardware to “gall, lock up, or seize” during assembly. To prevent this from occurring, it is **highly recommended** that the anti-seize supplied in the hardware bag be applied to the mating surfaces of all stainless steel fasteners before assembly. Lubricants containing molybdenum disulfide, graphite, mica or talc may also be used.



CAUTION:

DO NOT EXCEED THE MAXIMUM TORQUE RATING ON ALL BOLTS OF 20 FT-LBS.



WARNING:

FAILURE TO APPLY A SUITABLE LUBRICANT TO THE MATING SURFACES OF STAINLESS STEEL THREADED FASTENERS MAY CAUSE GALLING AND/OR SEIZING OF ASSEMBLY.

8. Two people will be needed to mount the Power Drive onto the Railway. The following precautions must be observed when lifting any part of this equipment:
 - a. Be sure of your footing.
 - b. Bend your knees and lift with your legs.
 - c. Hold the equipment section close to your body when lifting.



WARNING:

THE DRIVE IS TOO HEAVY TO SAFELY MOUNT IT SINGLE-HANDEDLY. ATTEMPTING THIS CAN CAUSE EQUIPMENT DAMAGE AND/OR PERSONAL INJURY.

3.2 MOUNTING POWER DRIVE

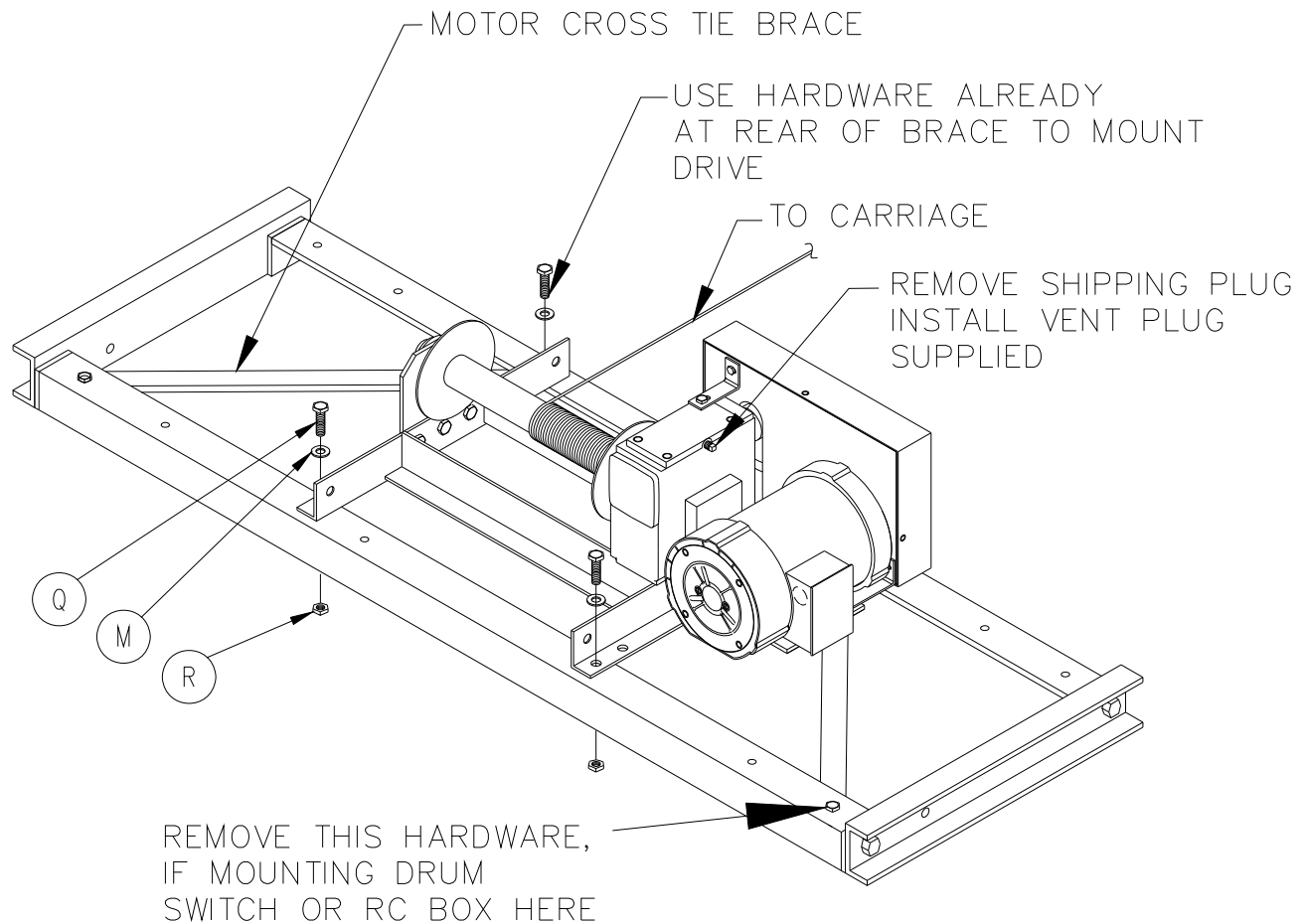

Figure 3-1.
Mounting Power Drive

1. **Refer to Figure 3-1.** Remove the drive unit from the carton by removing all applicable packaging hardware.
2. Remove one bolt from each motor cross tie brace as shown.
3. Mount the drive unit onto the motor cross ties and securely fasten with bolts removed in previous step and additional bolts supplied. Ensure drive unit is installed with the wire rope feeding off the top of the winch drum.
4. Use supplied hex wrench to remove red shipping pipe plug from reducer. Install vented pipe plug supplied with unit for proper operation.



CAUTION:

FAILURE TO INSTALL THE VENT PLUG CAN CAUSE PREMATURE FAILURE OF THE REDUCER SEALS AFTER EXTENDED USE AND VOID YOUR WARRANTY.

3.3 MOUNTING REMOTE CONTROL PANEL

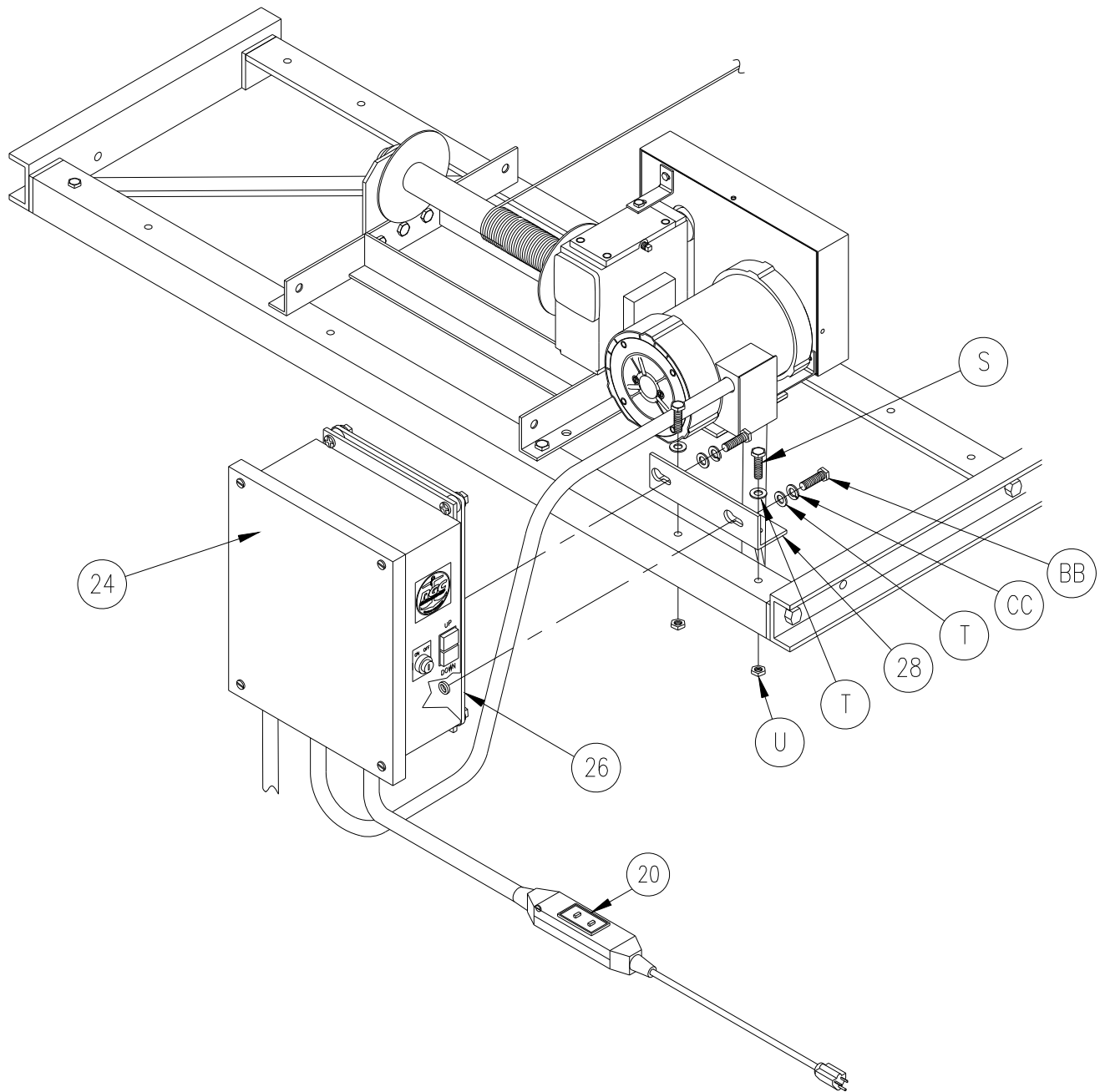

Figure 3-2.
Mounting Remote Control

1. **Refer to Figure 3-2.** Attach universal mounting bracket (28) to railway motor cross tie. Attach RC panel assembly (24) to mounting bracket using supplied hardware and lower set of threaded holes in RC mounting plate (26).
2. **Refer to Figure 3-4.** Fasten limit switch (25) to railway track, on motor side of power drive. Ensure switch is installed far enough away from power drive to prevent carriage or boat from contacting power drive causing damage to lift or boat.

3.4 MOUNTING POWER DRIVE MANUAL SWITCH

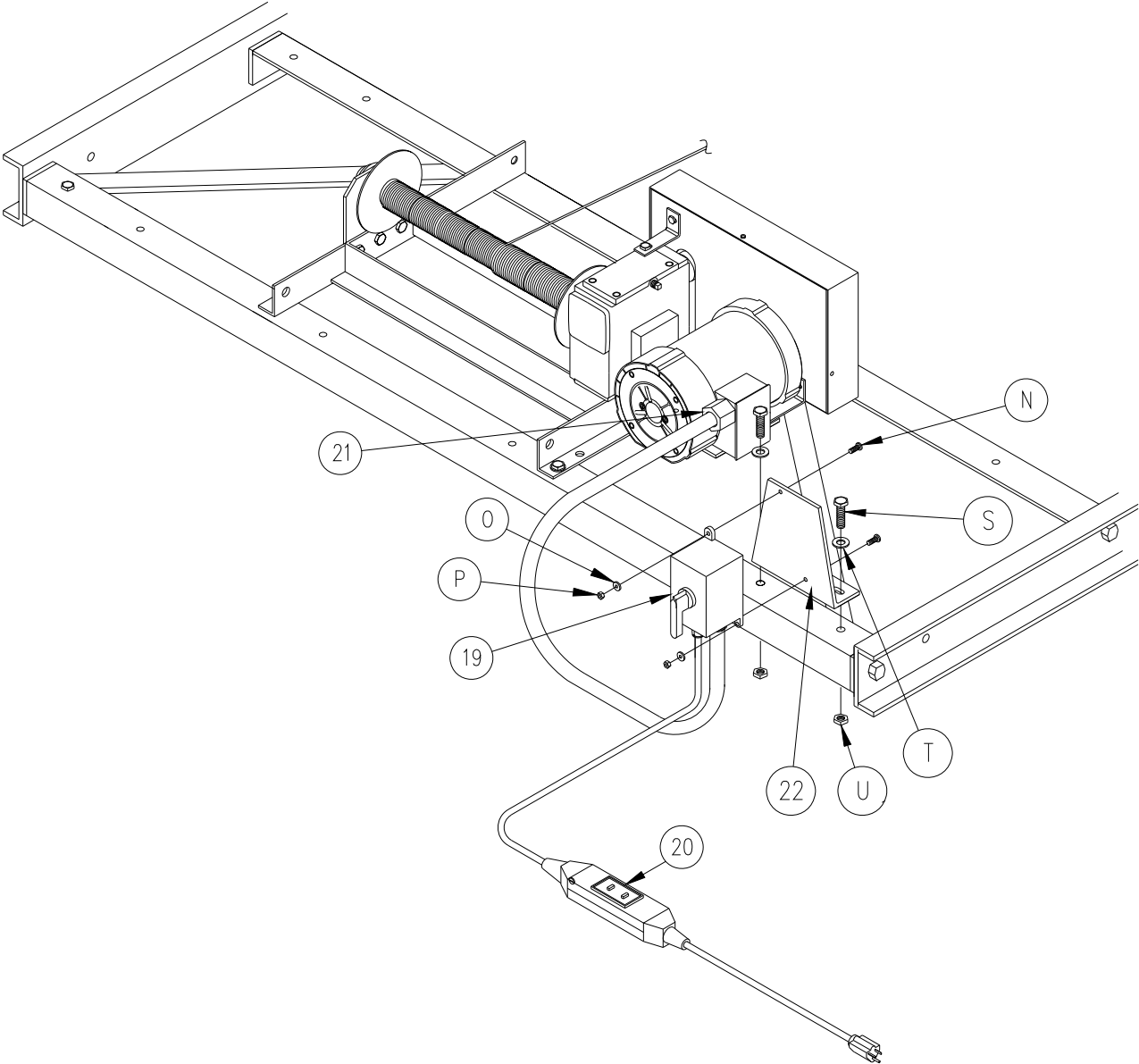

Figure 3-3.
Mounting Manual Switch

1. **Refer to Figure 3-3.** Mount reversing drum switch assembly (19) to frame using mounting bracket (22) and hardware as shown.

3.5 REEVING WIRE ROPE TO CARRIAGE STANDARD DRIVE

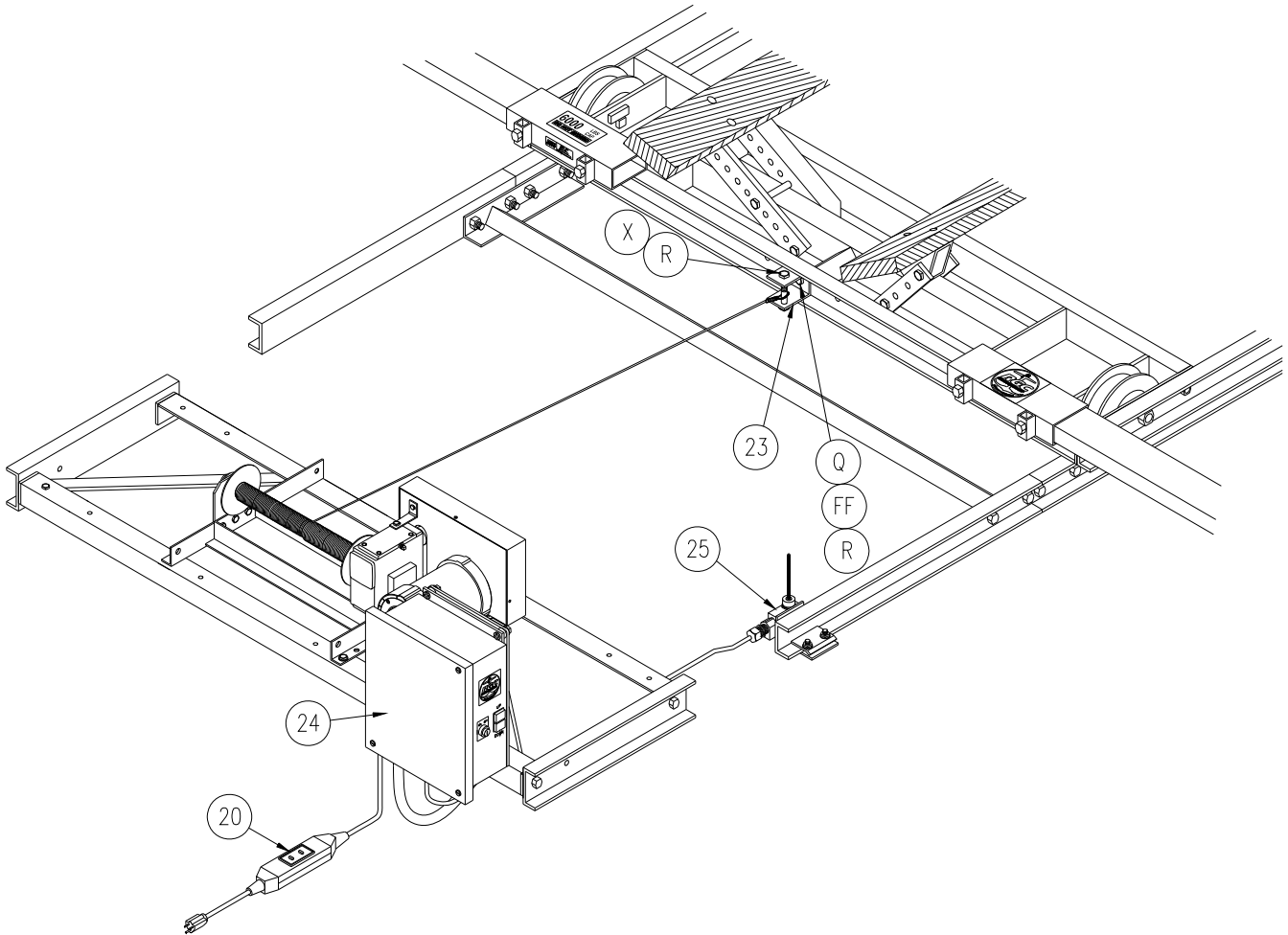

Figure 3-4.
Standard RC Power Drive Wire Rope Reeving for AR4K/BR4K and AR6K Railway



CAUTION:

IF THE RC PANEL IS EQUIPPED WITH AN EXTERNAL ANTENNA, THE ANTENNA SHOULD BE MOUNTED AS FAR AS POSSIBLE FROM THE ELECTRIC MOTOR.

1. **Refer to Figures 3-4.** Fasten pulley support bracket (23) to carriage as shown (fig. 3-4 center hole for AR4K and either hole for AR6K).
2. Position carriage approximately 10 feet away from power drive and lock into place, using wooden blocks clamped to top edge of track, at stern end of carriage, to prevent carriage from rolling down track.
3. Using leather gloves, unwind approximately 10 feet of wire rope from winch drum.
4. Attach wire rope loop to the pulley support bracket and secure with hardware (R & X).



CAUTION:

DO NOT REMOVE BLOCKS FROM TRACK AT THIS TIME.

3.6 REEVING WIRE ROPE TO CARRIAGE HEAVY DUTY DRIVE

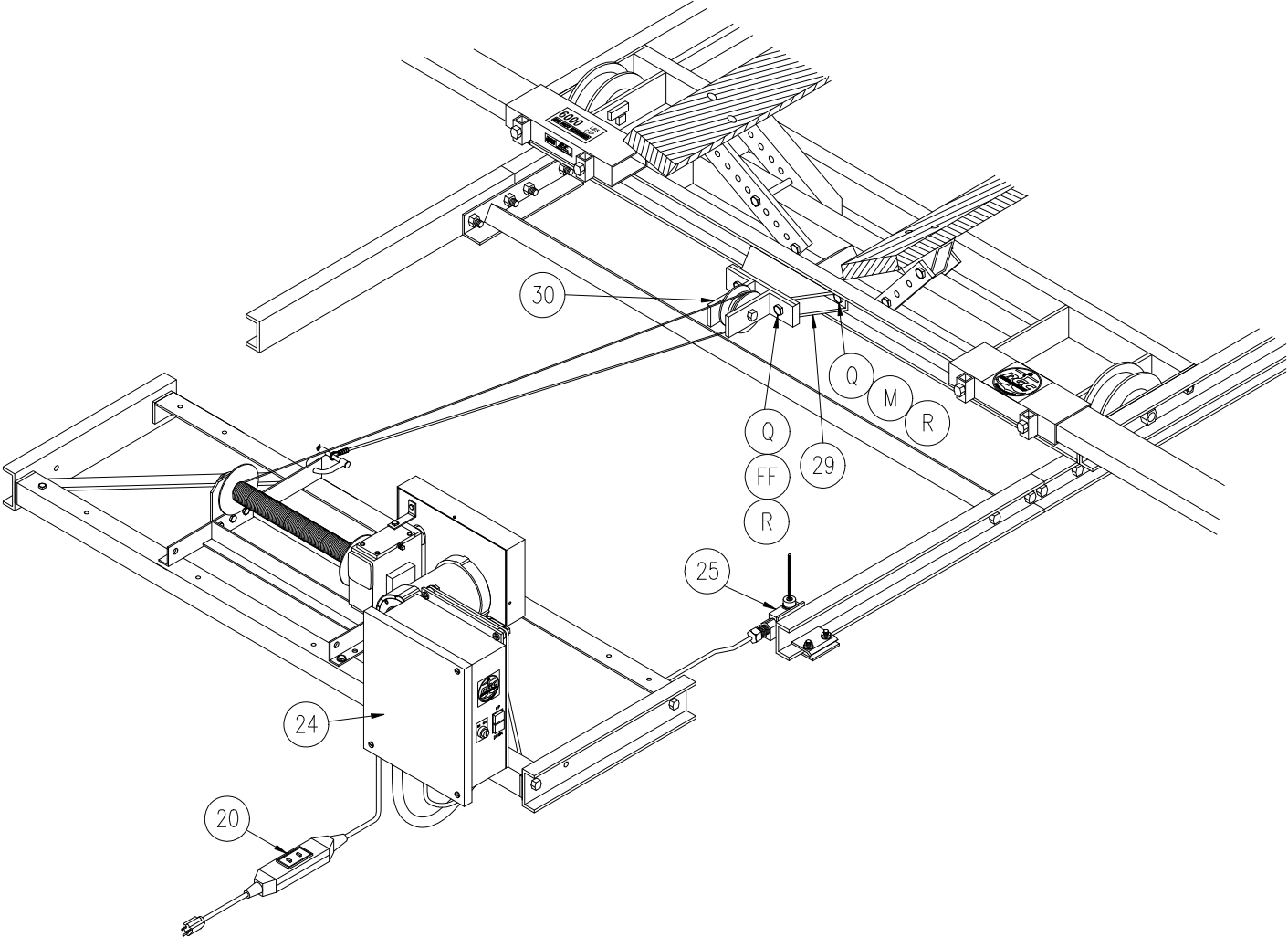

Figure 3-5
Heavy Duty RC Power Drive Wire Rope Reeving for AR4K/BR4K Railway

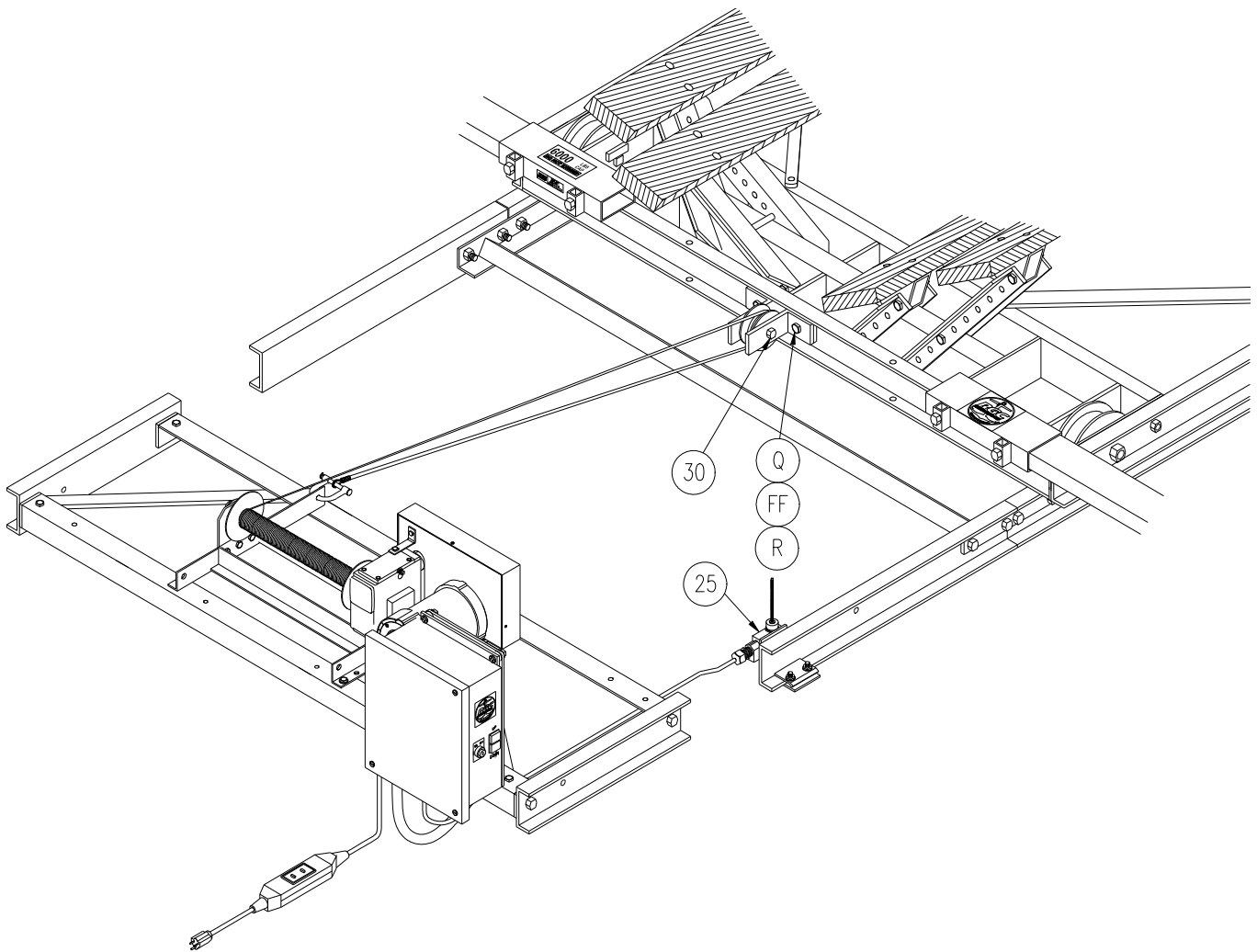

Figure 3-6
Heavy Duty RC Power Drive Wire Rope Reeving for AR6K



CAUTION:

IF THE RC PANEL IS EQUIPPED WITH AN EXTERNAL ANTENNA, THE ANTENNA SHOULD BE MOUNTED AS FAR AS POSSIBLE FROM THE ELECTRIC MOTOR.

1. **Refer to Figures 3-5 and 3-6.** Fasten P/P sheave assembly (30) to carriage as shown, omitting AR/BR 4K adapter tube (29) when using an AR6K carriage (fig. 3-5 for AR4K and fig. 3-6 for AR6K).
2. Attach shackle (9) to power drive frame as shown. Do not fasten pin.
3. Position carriage approximately 10 feet away from power drive and lock into place, using wooden blocks clamped to top edge of track, at stern end of carriage, to prevent carriage from rolling down track.
4. Using leather gloves, unwind approximately 20 feet of wire rope from winch drum.
5. Reeve loop end of wire rope over the top of single pulley block then under and back to the drive unit attaching loop end to frame mounted shackle with shackle pin. Securely fasten.



CAUTION:

DO NOT REMOVE BLOCKS FROM TRACK AT THIS TIME.

3.7 POWER SUPPLY CONNECTIONS

1. Ensure power supply is compatible with motor nameplate ratings. The motor must be connected to a properly rated branch circuit to help minimize voltage drops during operation.



WARNING:

THE POWER DRIVE AND SUPPLY LINE MUST BE INSTALLED AND INSPECTED BY A CERTIFIED ELECTRICIAN IN ACCORDANCE WITH LOCAL ELECTRICAL CODES. BECAUSE WATER AND ELECTRICITY ARE POTENTIAL SAFETY HAZARDS, THIS INSTALLATION MUST INCLUDE A PROPERLY WORKING GROUND FAULT CIRCUIT INTERRUPTER. (G.F.C.I.)

Use the following wire sizing guide as a reference in wiring the power drive.

WIRE SIZING GUIDE FOR REFERENCE ONLY

Distance → Motor amps ↓	50 feet	100 feet	150 feet	200 feet	250 feet	300 feet	350 feet	400 feet
5 amp	#12 awg	#12 awg	#10 awg	#10 awg	#8 awg	#8 awg	#6 awg	#6 awg
7.5 amp	#12 awg	#12 awg	#10 awg	#10 awg	#8 awg	#8 awg	#6 awg	#6 awg
10 amp	#12 awg	#10 awg	#10 awg	#8 awg	#8 awg	#6 awg	#6 awg	#4 awg
12.5 amp	#12 awg	#10 awg	#10 awg	#8 awg	#8 awg	#6 awg	#6 awg	#4 awg
15 amp	#10 awg	#10 awg	#8 awg	#8 awg	#6 awg	#6 awg	#4 awg	#4 awg
17.5 amp	#10 awg	#10 awg	#8 awg	#8 awg	#6 awg	#6 awg	#4 awg	#4 awg
20 amp	#10 awg	#8 awg	#8 awg	#6 awg	#6 awg	#4 awg	#4 awg	#2 awg
22.5 amp	#10 awg	#8 awg	#8 awg	#6 awg	#6 awg	#4 awg	#4 awg	#2 awg
25 amp	#8 awg	#8 awg	#6 awg	#6 awg	#4 awg	#4 awg	#2 awg	#2 awg

awg = American Wire Gauge

amp = Motor Full Load Current

feet = Distance From MAIN Breaker Box to Control Panel



CAUTION:

THE ABOVE CHART IS ONLY A REFERENCE FOR WIRE SIZING. DO NOT USE THIS INFORMATION TO ACTUALLY SIZE THE WIRE TO YOUR POWER DRIVE. YOU MUST CONSULT A LICENSED ELECTRICAL CONTRACTOR WHO WILL DETERMINE THE ACTUAL WIRE SIZE REQUIRED TO SUIT YOUR PARTICULAR APPLICATION.

2. Use plastic zip ties and any other supplies needed to tie off the electrical cords. This protects the cords from abrasion, sharp objects, water contact and other harm.

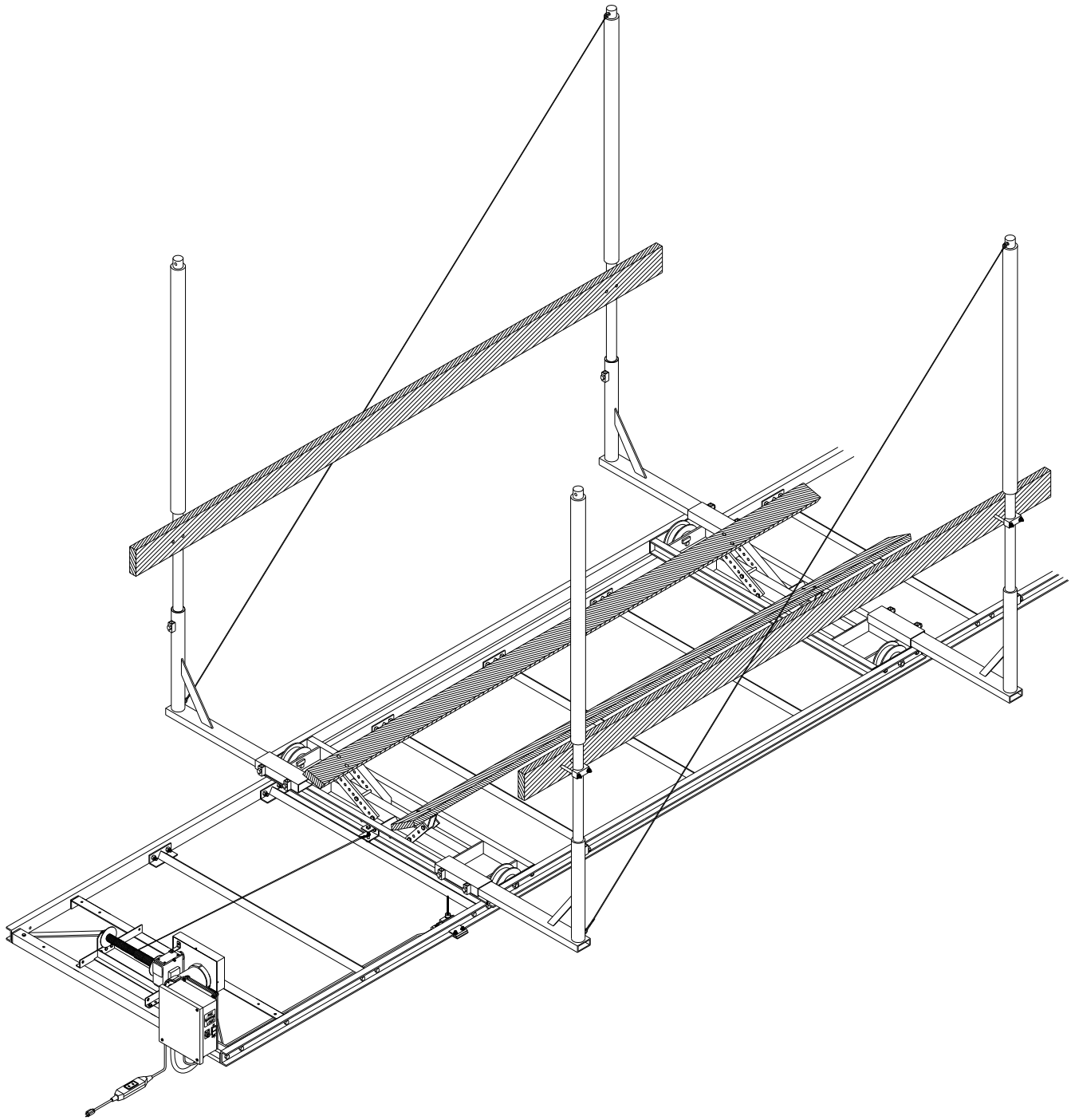

Figure 3-7
AR Standard Beacher Railway with Remote Control Power Drive

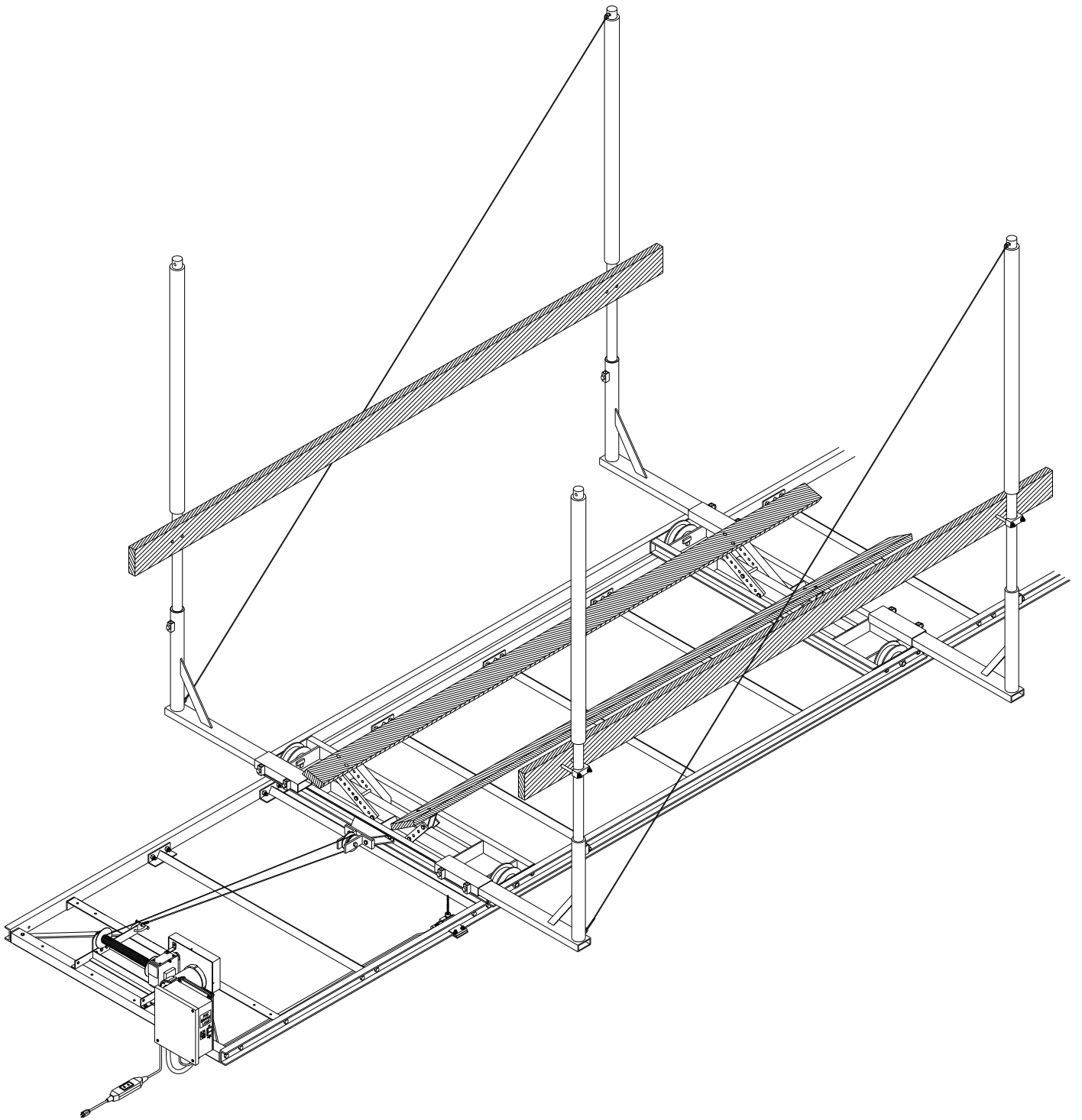

Figure 3-8
AR Heavy Duty Beacher Railway With Remote Control Power Drive

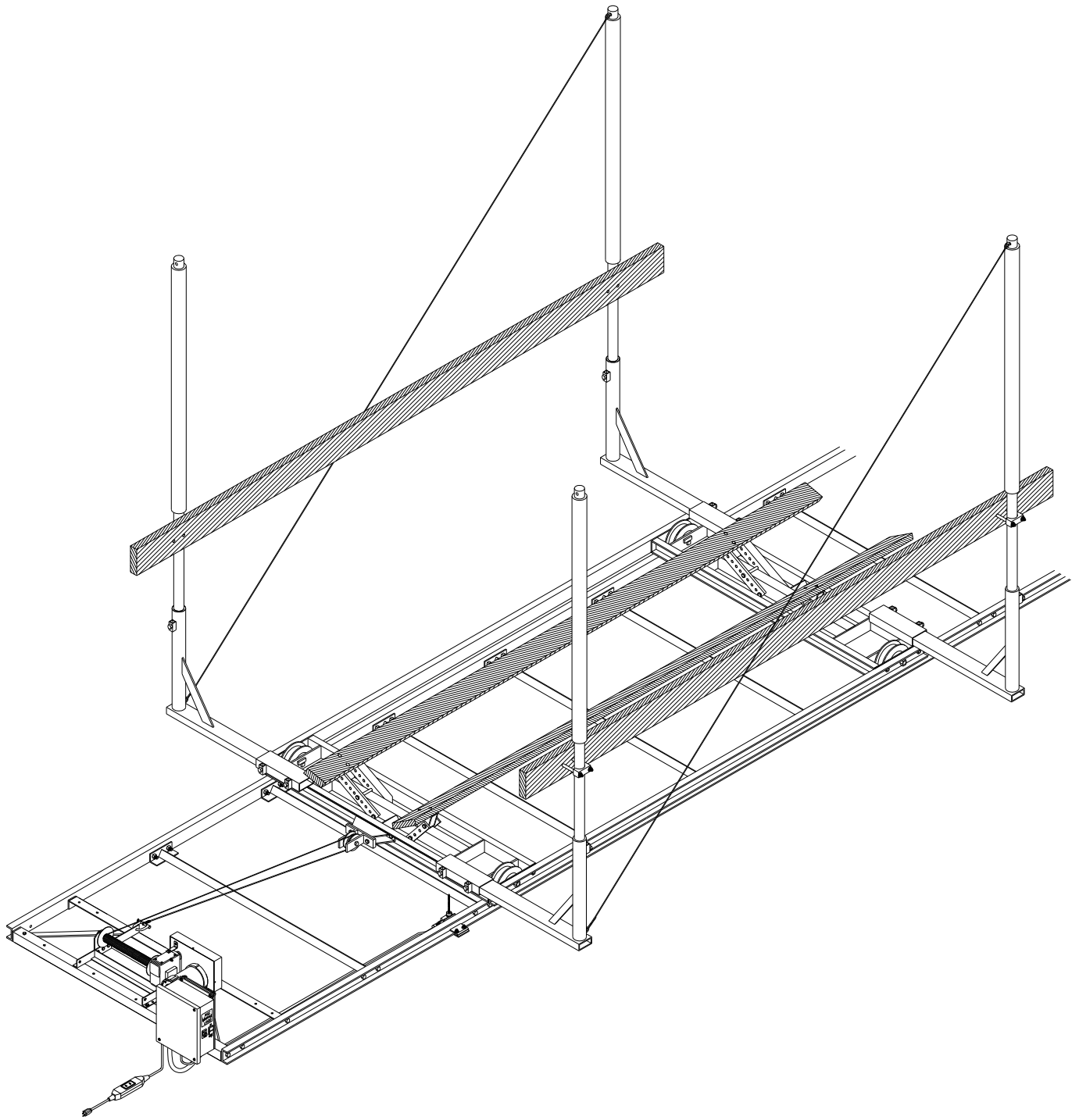

Figure 3-9
AR Heavy Duty Beacher Railway With Remote Control Power Drive

4 OPERATION

4.1 TESTING POWER DRIVE OPERATION

After the railway and power drive installation is complete, it is important that the power drive functions properly. Test the power drive operation as follows:

1. Turn and hold the switch in the UP position to raise the empty carriage about one-foot to allow for removal of wood blocks installed in section 3. Then release the switch. If the power drive is functioning properly, the power drive will stop and hold the carriage at any position. The wire rope on the power drive must reeve on the top of the drum when operating.
2. For remote control power drive, press and hold UP button to raise the carriage or press and hold DOWN button to lower carriage. Release button to stop operation.



WARNING:

THE POWER DRIVE WIRE ROPE MUST REEVE FROM THE TOP OF THE DRUM TO OPERATE PROPERLY AND PREVENT PERSONAL INJURY AND OR EQUIPMENT DAMAGE.



WARNING:

ENSURE WIRE ROPE DOES NOT CONTACT ANY OF THE RAILWAY OR POWER DRIVE STRUCTURAL COMPONENTS TO PREVENT PERSONAL INJURY AND OR EQUIPMENT DAMAGE.

3. Repeat Step 1 in the DOWN direction.
4. Operate the power drive and empty carriage in both directions for the full length of the railway ensuring no interference with railway or power drive structural components.
5. Contact your authorized dealer if the power drive fails to perform as described in this section.

4.2 RAISING AND LOWERING THE CARRIAGE

1. Raise the carriage by turning and holding the switch in the UP position until the carriage is at the desired level. The switch can be released any time to stop the carriage movement.
2. For remote control power drive, press and hold UP button to raise the carriage or press and hold DOWN button to lower carriage. Release button to stop operation.



WARNING:

DO NOT STAND OR WALK ON THE RAILWAY CARRIAGE OR SIT IN THE BOAT WHILE THE CARRIAGE IS IN ANY RAISED POSITION.

3. Lower the carriage by turning and holding the switch in the DOWN position. The switch can be released any time to stop the carriage movement. Do not continue lowering the carriage after the boat floats freely from it. Excessive slack in wire rope may cause wire rope and or equipment damage.
4. Check the railway periodically for frayed wire rope and/or binding pulleys.
5. Never operate the power drive from inside the boat or railway.
6. Keep fingers and clothing clear of all moving parts of the railway and power drive. Keep people clear during operation of the railway.

4.3 SECURING RAILWAY WHEN NOT IN USE

At the end of operation, secure the power drive and railway to prevent unauthorized use. Proceed as follows:

1. Raise the carriage to the desired height.
2. Disconnect and lock out the power source to prevent unauthorized use of the power drive when it is unattended.

4.4 PRE-OPERATIVE CHECKS

Review the following Pre-Lifting Checklist. Only those who have read and understood this manual, the railway manual, and related equipment manuals are qualified to do this inspection.

- Ensure the railway installation will clear all power lines and obstructions.
- Ensure all structural members of the railway are free of defects and damage that may affect the integrity.
- Ensure that the power drive has been inspected and installed by a certified electrician in accordance with local electrical codes. A Ground Fault Circuit Interrupter (G.F.C.I.) must be installed by your electrician and work properly.
- Ensure wire rope reeves on and off the top of the power drive drum.
- Ensure that any user or dealer installed locking devices have been removed before operating the railway.
- Operate the railway first without, and then with, your boat on the carriage to test the operation of both the railway and the power drive.
- Ensure the boat is properly positioned on the carriage before doing any raising or lowering.
- Ensure the railway is not being used beyond its rated capacity.
- Ensure any drain plug is in place on the boat before launching.
- Conduct the wire rope inspection procedure described in your railway manual at least monthly.
- Ensure all suspended track sections and splice connections are rigidly supported.
- Ensure the power drive winch drum is parallel to carriage and railway cross ties.
- Ensure the wire rope ends are securely fastened.
- Ensure the power drive is securely fastened to motor cross ties and braces.
- Ensure the vent plug is installed on the gearbox reducer.
- Read the railway and power drive manual and ensure that everyone understands the proper operating procedures.
- Understand the use of all controls and connections provided with the direct drive.
- Do not use the railway or power drive if either shows any signs of damage.
- Ensure that all bolts and nuts are fastened securely prior to operation.
- Check that the power drive wire rope is reeved properly.
- Never try lifting anything other than a boat with this railway.
- Do not operate the railway under the influence of drugs, alcohol, or medication.
- Never try to raise or launch your boat in severe rough water conditions. This can damage your boat and/or the railway.

5 INSPECTION AND MAINTENANCE

5.1 GENERAL MAINTENANCE RULES

1. Do not allow persons other than authorized service personnel to repair this equipment.
2. Do not weld or otherwise modify the beacher. Such alterations may weaken the structural integrity of the beacher railway and invalidate your warranty.
3. Completely lower the carriage before performing any type of maintenance or repair.



WARNING:

NEVER ALLOW ANYBODY TO WORK IN OR ON THE BOAT WHEN IT IS POSITIONED ON THE CARRIAGE. IF THE WINCH SHOULD START FREEWHEELING, SERIOUS INJURY OR DEATH COULD RESULT.

IF FREEWHEELING STARTS, NEVER TRY TO STOP IT. ALTHOUGH A SPIN DOWN OR “FREEWHEELING” CAN CAUSE BEACHER OR BOAT DAMAGE, TRYING TO STOP FREEWHEELING CAN CAUSE SERIOUS PERSONAL INJURY.

5.2 WIRE ROPE INSPECTION PROCEDURE

Inspect the wire rope at least once per month for signs of wear, damage, or pinching. Inspect the entire wire rope working length. Thoroughly inspect the rope sections that pass over sheaves or drums, or that make opposing turns. Inspect wire rope and end attachments carefully. While inspecting, examine any sheaves, guards, guides, drums, flanges, and other surfaces contacting wire rope during operation. Correct any condition harming the rope in use or other damage or worn surfaces at this time.



CAUTION:

WEAR HEAVY LEATHER GLOVES WHEN HANDLING WIRE ROPE. INSUFFICIENT HAND PROTECTION WHEN HANDLING WIRE ROPE CAN CAUSE PERSONAL INJURY.

Remove and immediately replace wire rope with one or more of the following defects:

1. Corrosion
2. Broken wires:
 - (a) One or more valley breaks. A valley break is a wire break occurring in the valley between two adjacent strands.
 - (b) Six randomly distributed broken wires in one rope lay. A rope lay is the length of rope along which one strand makes a complete revolution around the rope. See **Figure 5-1**. If a broken wire or wires are localized in the end attachment of an operating rope and making a new attachment can eliminate this condition, this may be done instead of replacing the entire rope. Keeping the rope clean and wound evenly on the winch drum will increase its life and efficiency.
3. Abrasion: Scrubbing, flattening or peening causing loss of more than one-third of the original diameter of the outside wires.
4. Kinking: Severe kinking, crushing, bird caging or other damage causing distortion of the rope structure. Bird caging is a bulging in the wire rope caused by the individual wires becoming untwisted. This untwisting of individual wires is usually caused by impact loading on the wire rope (such as a sudden stop).

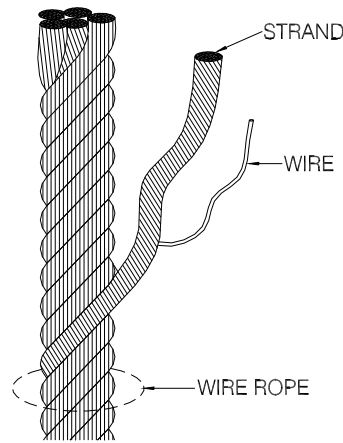

Figure 5-1.
Wire Rope Components

5. Heat damage: Evidence of any heat damage caused by a torch or by contact with electrical wires.
6. Reduction of more than 3/64 inch from 1/4 inch diameter wire rope, 1/16 inch from 5/16 inch or 3/8 inch diameter wire rope. Marked reduction in diameter indicates core deterioration.

5.3 ANNUAL INSPECTION AND MAINTENANCE

At least once a year, the beacher must be thoroughly inspected using the following procedure.



WARNING:
DO NOT ALLOW ANYBODY TO USE THE BEACHER RAILWAY UNTIL THIS MAINTENANCE IS COMPLETED.

1. Completely lower carriage and remove boat. Do not raise empty carriage at this time.
2. Tighten all bolts.
3. Check the sheaves to ensure that they spin freely. If they bind, replace them immediately.
4. Check frame thoroughly for defects.
5. The power drive maintenance schedule must be followed to avoid possible equipment failure or personal injury.
6. Remove optional power drive cover (if equipped) to inspect the power drive. Do not manipulate any of the power drive mechanisms when the carriage is raised.
7. Lubricate cables and sheave bearings.
8. Lubricate cable drum hub.
9. Replace cover (if equipped).



WARNING:
AFTER EVERY POWER DRIVE MAINTENANCE, TEST THE POWER DRIVE AS DESCRIBED IN POWER DRIVE INSTRUCTION MANUAL BEFORE LETTING ANYONE USE THE BEACHER RAILWAY.

10. Raise empty carriage above water line and clamp wheel chocks to both rails of track below carriage to hold carriage in place.
11. Lower carriage to rest against wheel chocks.

12. Tighten all bolts.
13. Check carriage thoroughly for defects.
14. Lubricate remainder cables and sheaves.
15. Grease carriage wheel axles.
16. Raise carriage and remove wheel chocks.

5.4 STORAGE PROCEDURE



CAUTION:

DO NOT STORE THE LIFT IN THE WATERWAY IF FREEZING TEMPERATURES ARE EXPECTED. THIS WILL CAUSE EQUIPMENT DAMAGE.

1. Ensure boat is properly positioned on carriage.
2. A boat that has water in it from a rainstorm could exceed the recommended weight capacity for the beacher. Just 1 gallon of water weighs over 8 pounds. Be sure to remove the plug while the boat is up on the beacher. Make sure you replace the plug prior to launching your boat.
3. Protect your beacher as far as possible from damage caused by environmental factors such as airborne fallout, chemicals, tree sap, and weather hazards.
4. Never use the beacher to hang or store any auxiliary equipment such as boating hardware.
5. Do not allow anyone to swim or play near the beacher at any time.
6. Disconnect and lock out the power to the electric motor when your beacher is unattended. Never assume you will find the beacher railway in the same condition that you left it.

6 TROUBLESHOOTING

The following chart is intended to assist with troubleshooting the Railway Power Drive and Remote Control panel. While not all inclusive, the chart outlines the most common causes of a problem and the recommended course of action



WARNING:

THE CORRECTIVE ACTIONS LISTED IN THE FOLLOWING CHART MUST BE DONE BY A LICENSED ELECTRICIAN TO PREVENT EQUIPMENT DAMAGE AND POSSIBLE PERSONAL INJURY.

SYMPTOM	CAUSE AND CORRECTIVE ACTION
Lift does not go up or down.	<ol style="list-style-type: none"> 1. Check to see if you have incoming power—restore it if required. 2. Wrong voltage in use—refer to the wiring information in Chapter 2.
Lift goes up but not down.	<ol style="list-style-type: none"> 1. Bad relay, contactor, or switch—replace as required. 2. Improper motor wiring—refer to Chapter 2 and the motor manufacturer’s instruction manual.
Remote unit only works in one direction.	<ol style="list-style-type: none"> 1. If both lights work, refer to the corrective actions above. 2. If this test fails, the remote unit is bad—contact your authorized RGC dealer.
Remote unit does not work at all.	Bad battery—replace with a new one.
RC panel clicks but motor does not move.	<ol style="list-style-type: none"> 1. Bad motor leads or motor—replace as required. 2. Improper wiring—refer to Chapter 2 and to the motor manufacturer’s instruction manual.
Transmitter only works close to the RC panel.	Tune transmitter as follows: <ol style="list-style-type: none"> 1. Remove battery cover and top cover of the hand held transmitter. There is a small brass screw above the UP/DOWN buttons on the remote unit. 2. With the UP or DOWN button depressed, stand about 50 feet from the panel. 3. Slowly turn the small brass screw clockwise or counterclockwise until the lift goes in that direction. Do NOT rotate the screw more than 360°.
Power drive does not start when switch is turned to either the UP or DOWN position.	Poor electrical connection—clean as required and ensure that all connections are tight. Faulty GFCI cord – inspect / replace Power drive wired improperly—do NOT tamper with either electrical supply or the power line connections at either the drive or the main breaker. Consult a licensed electrical contractor.

SYMPTOM	CAUSE AND CORRECTIVE ACTION
<p>Power drive starts, but resists carriage raising.</p>	<p>Power drive has been reeved incorrectly—wire rope must reeve on and off the top of drum to raise and lower carriage. See Chapter 3.</p> <p>Shaft bearings corroded – inspect/lubricate/replace.</p> <p>Sheaves binding—inspect/lubricate/replace.</p> <p>Cable is rubbing against the drive frame—repeat power drive reeving if necessary as described in Chapter 3.</p>
<p>Power drive is turning wire rope drum, but carriage raising is either difficult or impossible.</p>	<p>Carriage is binding because frame is either not square or not set level in the water—refer to Chapter 3.</p> <p>Cable is broken—replace as required.</p> <p>Sheaves binding—inspect/lubricate/replace.</p> <p>Cable is excessively worn—replace as required and follow monthly wire rope inspection procedure described in Chapter 5.</p> <p>Load exceeds rated capacity—refer to Chapter 2. Reduce load weight as needed.</p> <p>Broken drive chain – replace</p> <p>User or dealer installed locking devices are in place—remove these.</p> <p>Auxiliary equipment such as boating hardware is being improperly hung on lift—remove this equipment permanently.</p>

7 PARTS LISTS

Each reference number or letter in the following parts lists can be matched with the reference number or letter referred to in both the text and illustrations.



WARNING:

FAILURE TO APPLY A SUITABLE LUBRICANT TO THE MATING SURFACES OF STAINLESS STEEL THREADED FASTENERS MAY CAUSE GALLING AND/OR SEIZING OF ASSEMBLY.

7.1 STANDARD RAILWAY POWER DRIVE

REF #	PART #	QTY	DESCRIPTION
1	6733263	1	REDUCER 60:1 SGL SHAFT
2	6500644	1	MOTOR 1HP 115/230V
3	3307224	1	RPD DRUM WLDMT 2"
4	3320034	1	RAILWAY POWER DRIVE FRAME
5	7300009	100 FT	RAILWAY WIRE ROPE
6	7300612	1	SHEAVE AS44 X 5/8" ID
7	7333071	1	SHEAVE AS64 X 1" ID
8	6733629	1	V-BELT 4L33
9	3303533	1	BEARING PLATE
10	3307112	2	BELT COVER LOWER BRACKET
11	3307114	1	BELT COVER UPPER BRACKET
12	3307941	1	BELT COVER BACK
13	3307943	1	BELT COVER FRONT
14	6206211	1	SERIAL NUMBER TAG
15	6206971	1	RAILWAY WARNING DECAL
16	5100925	1	FLANGE BEARING
17	7300933	1	1/4 THIMBLE
18	7344601	2	3/16 OVAL NICO
A	5806152	2	5/16-18 X 1 CARRIAGE BOLT
B	5806224	4	5/16-18 X1 HEX HEAD BOLT
C	5806241	6	1/4-20 PAN HEAD SCREW
D	5806280	7	1/2-13 X 1 HEX HEAD BOLT
E	5806289	1	1/2-13 X 3/4 HEX HEAD BOLT
F	5806334	1	5/16-18 TRUSS HEAD BOLT
G	5806367	3	5/16-18 LOCK NUT
H	5806379	3	1/2-13 HEX NUT GR 5
I	5806401	5	5/16 FLAT WASHER
J	5806402	4	5/16 EXT TOOTH WASHER
K	5806375	4	5/16-18 HEX NUT
L	5806412	7	1/2 EXT TOOTH WASHER
M	5896955	2	1/4 FLAT WASHER SS
-	3307410	1	RAILWAY REVERSING SWITCH ASSY
-			Consisting of:

19	5433715	1	REVERSING DRUM SWITCH
20	5406987	1	GFCI 20A IN LINE CORD
21	5403874	1	WATERTITE CABLE FITTING
22	3307415	1	DRUM SWITCH MOUNT BRACKET
N	5894136	2	#10-24 MACHINE SCREW
O	5894102	2	#10 FLAT WASHER
P	5893100	2	#10-24 NYLOCK HEX NUT
-	3307332	1	RPD STD BOB
-			Consisting of:
Q	5896283	3	1/2-13 X 1-3/4 HEX HEAD BOLT SS
FF	5896400	3	1/2 FLAT WASHER
R	5897018	4	1/2-13 NYLOCK HEX NUT SS
S	5896249	2	3/8-16 X 1-1/2 HEX HEAD BOLT
T	5896406	2	3/8 FLAT WASHER
U	5897016	2	3/8-16 NYLOCK HEX NUT SS
V	5806184	1	WRENCH L HANDLE HEX 5/32 X 4-1/8
W	5806187	1	WRENCH L HANDLE HEX 3/16 X 4-1/2
23	3502410	1	AR/BR 4K PULLEY SUPPORT BRACKET
X	5896286	1	1/2-13 X 2-1/2 SS HEX HEAD BOLT

7.2 STANDARD RC RAILWAY POWER DRIVE

REF #	PART #	QTY	DESCRIPTION
1	6733263	1	REDUCER 60:1 SGL SHAFT
2	6500644	1	MOTOR 1HP 115/230V
3	3307224	1	RPD DRUM WLDMT 2"
4	3320034	1	RAILWAY POWER DRIVE FRAME
5	7300009	100 FT	RAILWAY WIRE ROPE
6	7300612	1	SHEAVE AS44 X 5/8" ID
7	7333071	1	SHEAVE AS64 X 1" ID
8	6733629	1	V-BELT 4L33
9	3303533	1	BEARING PLATE
10	3307112	2	BELT COVER LOWER BRACKET
11	3307114	1	BELT COVER UPPER BRACKET
12	3307941	1	BELT COVER BACK
13	3307943	1	BELT COVER FRONT
14	6206211	1	SERIAL NUMBER TAG
15	6206971	1	RAILWAY WARNING DECAL
16	5100925	1	FLANGE BEARING
17	7300933	1	1/4 THIMBLE
18	7344601	2	3/16 OVAL NICO
A	5806152	2	5/16-18 X 1 CARRIAGE BOLT
B	5806224	4	5/16-18 X1 HEX HEAD BOLT

C	5806241	6	1/4-20 PAN HEAD SCREW
D	5806280	7	1/2-13 X 1 HEX HEAD BOLT
E	5806289	1	1/2-13 X 3/4 HEX HEAD BOLT
F	5806334	1	5/16-18 TRUSS HEAD BOLT
G	5806367	3	5/16-18 LOCK NUT
H	5806379	3	1/2-13 HEX NUT GR 5
I	5806401	5	5/16 FLAT WASHER
J	5806402	4	5/16 EXT TOOTH WASHER
K	5806375	4	5/16-18 HEX NUT
L	5806412	7	1/2 EXT TOOTH WASHER
M	5896955	2	1/4 FLAT WASHER SS
-	3320030	1	RC PANEL ASSEMBLY W/INT. ANTENNA
			Consisting of:
20	5406987	1	GFCI 20A IN LINE CORD
24	3670604	1	RC PANEL ASSY-110V W/INTERNAL ANTENNA
25	3351403	1	RAILWAY LIMIT SWITCH ASSEMBLY W/BRKT
26	5033672	1	RC MTG PLATE ASSEMBLY
Y	5893101	4	1/4-20 NYLOCK NUT
Z	5896238	4	1/4-20 PAN HEAD SCREW SS
AA	5896955	4	1/4 FLAT WASHER SS
-	9737332	1	UNIVERSAL RC MOUNTING BRKT KIT
			Consisting of:
27	3606922	1	2-HOLE PLATE
28	5003740	1	RC UNIVERSAL MOUNTING BRACKET
BB	5896246	2	3/8 X 3/4 HEX HEAD BOLT
S	5896249	2	3/8 X 1-1/2 HEX HEAD BOLT
T	5896406	4	3/8 FLAT WASHER
U	5897016	2	3/8 NYLOCK HEX NUT
CC	5806243	2	3/8 SPLIT LOCK WASHER
DD	5896286	2	3/8-16 X 2-3/4 HEX HEAD BOLT
-	3307332	1	RPD STD BOB
-			Consisting of:
Q	5896283	3	1/2-13 X 1-3/4 HEX HEAD BOLT SS
FF	5896400	3	1/2 FLAT WASHER
R	5897018	4	1/2-13 NYLOCK HEX NUT SS
S	5896249	2	3/8-16 X 1-1/2 HEX HEAD BOLT
T	5896406	2	3/8 FLAT WASHER
U	5897016	2	3/8-16 NYLOCK HEX NUT SS
V	5806184	1	WRENCH L HANDLE HEX 5/32 X 4-1/8
W	5806187	1	WRENCH L HANDLE HEX 3/16 X 4-1/2
23	3502410	1	AR/BR 4K PULLEY SUPPORT BRACKET
X	5896286	1	1/2-13 X 2-1/2 SS HEX HEAD BOLT

7.3 HEAVY DUTY RAILWAY POWER DRIVE

REF #	PART #	QTY	DESCRIPTION
1	6733263	1	REDUCER 60:1 SGL SHAFT
2	6500646	1	MOTOR 1.5HP 115/230V
3	3307224	1	RPD DRUM WLDMT 2"
4	3320034	1	RAILWAY POWER DRIVE FRAME
5	7300009	200 FT	RAILWAY WIRE ROPE
6	7300612	1	SHEAVE AS44 X 5/8" ID
7	7300613	1	SHEAVE AS44 X 1" ID
8	6733628	1	V-BELT 4L29
9	3303533	1	BEARING PLATE
10	3307112	2	BELT COVER LOWER BRACKET
11	3307114	1	BELT COVER UPPER BRACKET
12	3307941	1	BELT COVER BACK
13	3307943	1	BELT COVER FRONT
14	6206211	1	SERIAL NUMBER TAG
15	6206971	1	RAILWAY WARNING DECAL
16	5100925	1	FLANGE BEARING
17	7300933	1	1/4 THIMBLE
18	7344601	2	3/16 OVAL NICO
A	5806152	2	5/16-18 X 1 CARRIAGE BOLT
B	5806224	4	5/16-18 X1 HEX HEAD BOLT
C	5806241	6	1/4-20 PAN HEAD SCREW
D	5806280	7	1/2-13 X 1 HEX HEAD BOLT
E	5806289	1	1/2-13 X 3/4 HEX HEAD BOLT
F	5806334	1	5/16-18 TRUSS HEAD BOLT
G	5806367	3	5/16-18 LOCK NUT
H	5806379	3	1/2-13 HEX NUT GR 5
I	5806401	5	5/16 FLAT WASHER
J	5806402	4	5/16 EXT TOOTH WASHER
K	5806375	4	5/16-18 HEX NUT
L	5806412	7	1/2 EXT TOOTH WASHER
M	5896955	2	1/4 FLAT WASHER SS
-	3307410	1	RAILWAY REVERSING SWITCH ASSY
-			Consisting of:
19	5433715	1	REVERSING DRUM SWITCH
20	5406987	1	GFCI 20A IN LINE CORD
21	5403874	1	WATERTITE CABLE FITTING
22	3307415	1	DRUM SWITCH MOUNT BRACKET
N	5894136	2	#10-24 MACHINE SCREW
O	5894102	2	#10 FLAT WASHER
P	5893100	2	#10-24 HEX NUT
-	3307334	1	RPD HD HARDWARE BAG OF BOLTS

-			Consisting of:
29	3500525	1	AR/BR4K P/P ADAPTER TUBE
Q	5896283	6	1/2-13 X 1-3/4 HEX HEAD BOLT
FF	5896400	6	1/2 FLAT WASHER
R	5897018	6	1/2-13 NYLOCK HEX NUT SS
S	5896249	2	3/8-16 X 1-1/2 HEX HEAD BOLT SS
T	5896406	2	3/8 FLAT WASHER
U	5897016	2	3/8-16 NYLOCK HEX NUT SS
V	5806184	1	WRENCH L HANDLE HEX 5/32 X 4-1/8
W	5806187	1	WRENCH L HANDLE HEX 3/16 X 4-1/2
EE	7300150	1	SHACKLE 3/8 ROUND PIN 1 TON
30	3562163	1	P/P SHEAVE ASSY

7.4 HEAVY DUTY RC RAILWAY POWER DRIVE

REF #	PART #	QTY	DESCRIPTION
1	6733263	1	REDUCER 60:1 SGL SHAFT
2	6500646	1	MOTOR 1.5HP 115/230V
3	3307224	1	RPD DRUM WLDMT 2"
4	3320034	1	RAILWAY POWER DRIVE FRAME
5	7300009	200 FT	RAILWAY WIRE ROPE
6	7300612	1	SHEAVE AS44 X 5/8" ID
7	7300613	1	SHEAVE AS44 X 1" ID
8	6733628	1	V-BELT 4L29
9	3303533	1	BEARING PLATE
10	3307112	2	BELT COVER LOWER BRACKET
11	3307114	1	BELT COVER UPPER BRACKET
12	3307941	1	BELT COVER BACK
13	3307943	1	BELT COVER FRONT
14	6206211	1	SERIAL NUMBER TAG
15	6206971	1	RAILWAY WARNING DECAL
16	5100925	1	FLANGE BEARING
17	7300933	1	1/4 THIMBLE
18	7344601	2	3/16 OVAL NICO
A	5806152	2	5/16-18 X 1 CARRIAGE BOLT
B	5806224	4	5/16-18 X1 HEX HEAD BOLT
C	5806241	6	1/4-20 PAN HEAD SCREW
D	5806280	7	1/2-13 X 1 HEX HEAD BOLT
E	5806289	1	1/2-13 X 3/4 HEX HEAD BOLT
F	5806334	1	5/16-18 TRUSS HEAD BOLT
G	5806367	3	5/16-18 LOCK NUT
H	5806379	3	1/2-13 HEX NUT GR 5
I	5806401	5	5/16 FLAT WASHER
J	5806402	4	5/16 EXT TOOTH WASHER

K	5806375	4	5/16-18 HEX NUT
L	5806412	7	1/2 EXT TOOTH WASHER
M	5896955	2	1/4 FLAT WASHER SS
-	3320030	1	RC PANEL ASSEMBLY W/INT. ANTENNA
			Consisting of:
20	5406987	1	GFCI 20A IN LINE CORD
24	3670604	1	RC PANEL ASSY-110V W/INTERNAL ANTENNA
25	3351403	1	RAILWAY LIMIT SWITCH ASSEMBLY W/BRKT
26	5033370	1	RC MTG PLATE ASSEMBLY
Y	5893101	4	1/4-20 NYLOCK NUT
Z	5896283	4	1/4-20 X 1-1/2 PAN HEAD SCREW
AA	5896955	4	1/4 FLAT WASHER
-	9737332	1	UNIVERSAL RC MOUNTING BRKT KIT
			Consists of:
27	3606922	1	2-HOLE PLATE
28	5003740	1	RC UNIVERSAL MOUNTING BRACKET
BB	5896246	2	3/8 X 3/4 HEX HEAD BOLT
S	5896249	2	3/8 X 1-1/2 HEX HEAD BOLT
T	5896406	4	3/8 FLAT WASHER
U	5897016	2	3/8 NYLOCK HEX NUT SS
CC	5806243	2	3/8 SPLIT LOCK WASHER
DD	5896268	2	3/8-16 X 2-3/4 HEX HEAD BOLT
-	3307334	1	RPD HD HARDWARE BAG OF BOLTS
-			Consisting of:
29	3500525	1	AR/BR4K P/P ADAPTER TUBE
Q	5896283	6	1/2-13 X 1-3/4 HEX HEAD BOLT SS
FF	5896400	6	1/2 FLAT WASHER
R	5897018	6	1/2-13 NYLOCK HEX NUT SS
S	5896249	2	3/8-16 X 1 1/2 HEX HEAD BOLT
T	5896406	2	3/8 SAE FLAT WASHER
U	5897016	2	3/8-16 NYLOCK HEX NUTSS
V	5806184	1	WRENCH L HANDLE HEX 5/32 X 4-1/8
W	5806187	1	WRENCH L HANDLE HEX 3/16 X 4-1/2
EE	7300150	1	SHACKLE 3/8 ROUND PIN 1 TON
30	3562163	1	P/P SHEAVE ASSY

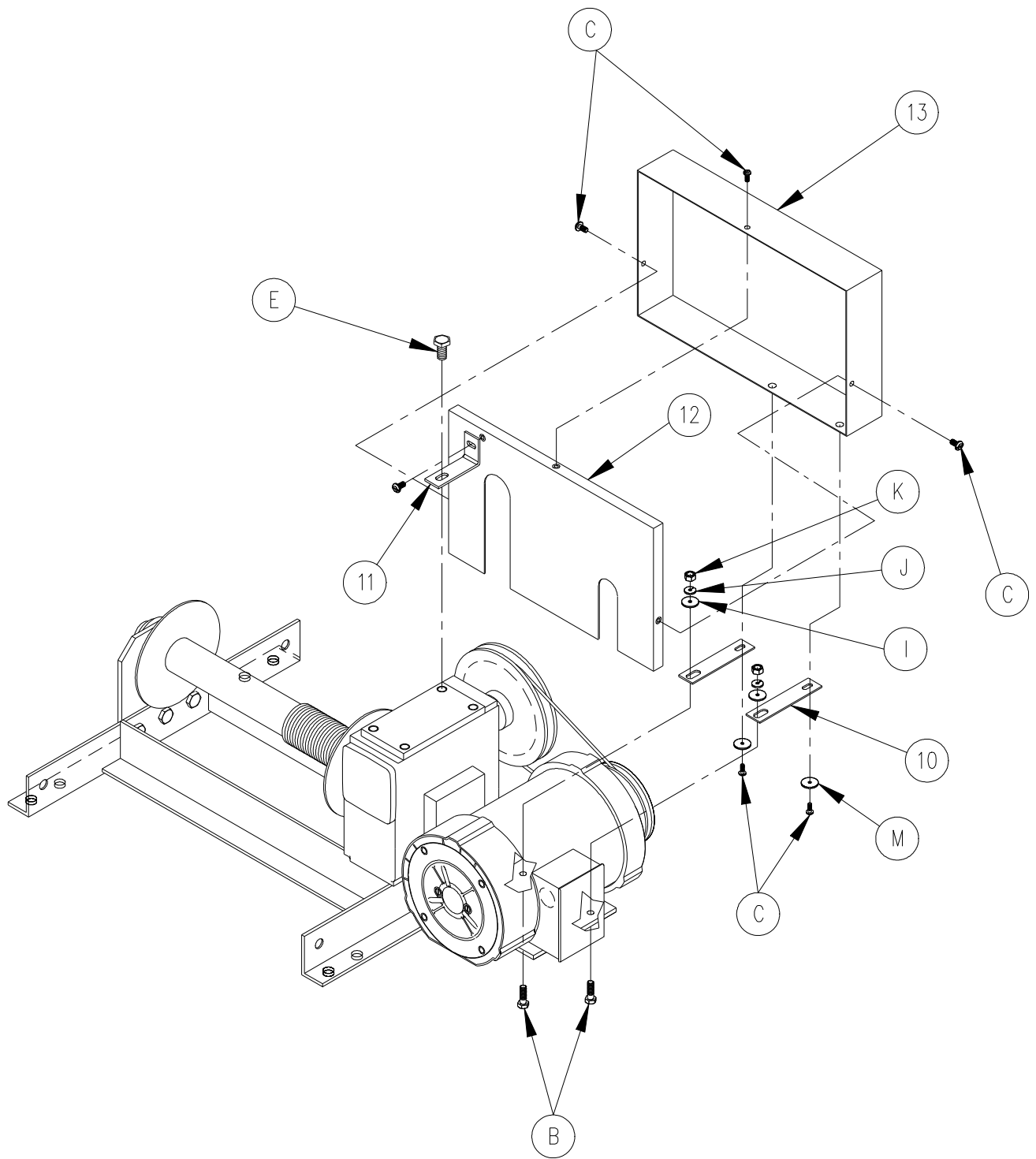

FIG 7-1
Railway Power Drive Belt Cover Assembly

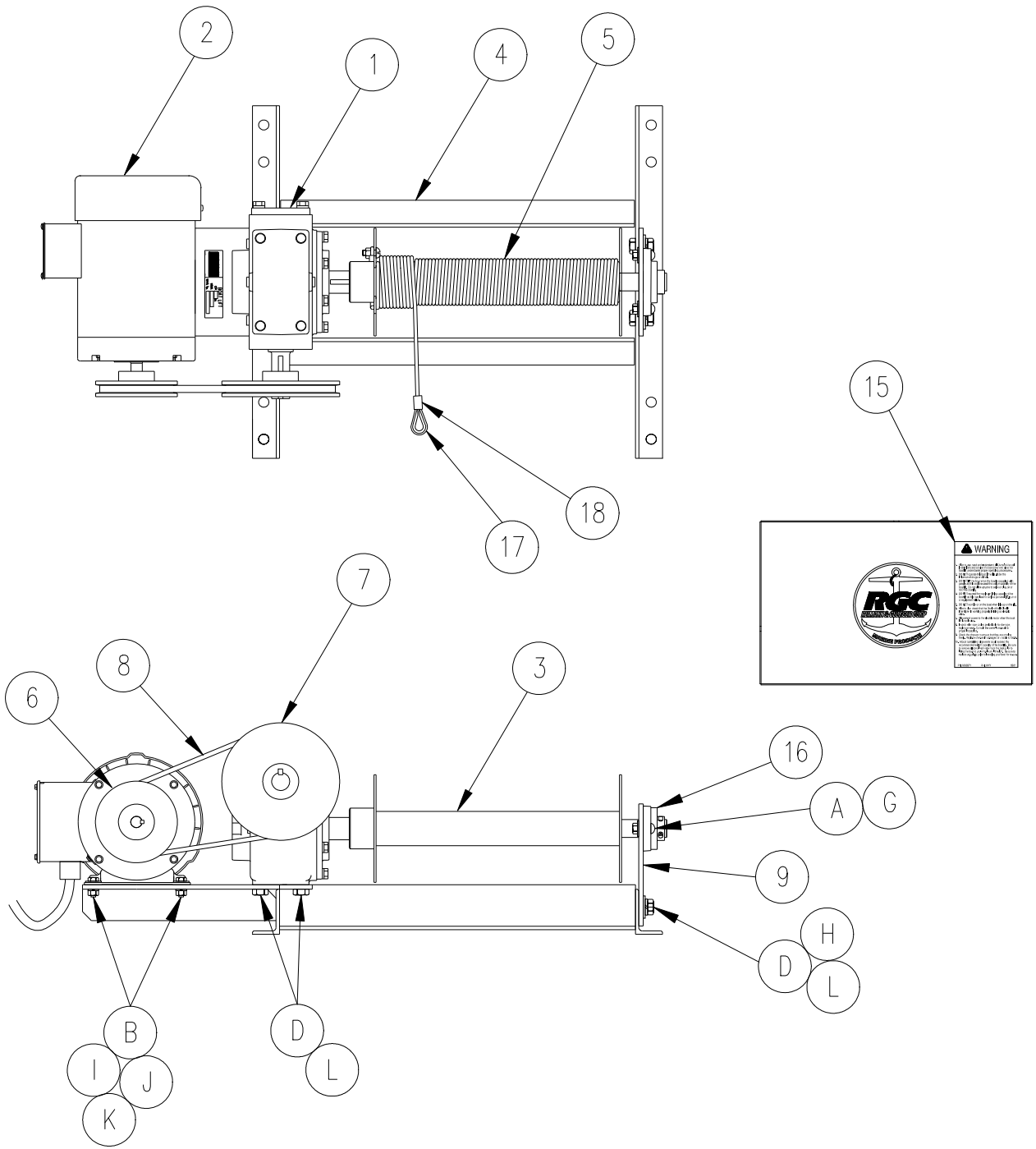

FIG 7-2
Standard Railway Power Drive Assembly

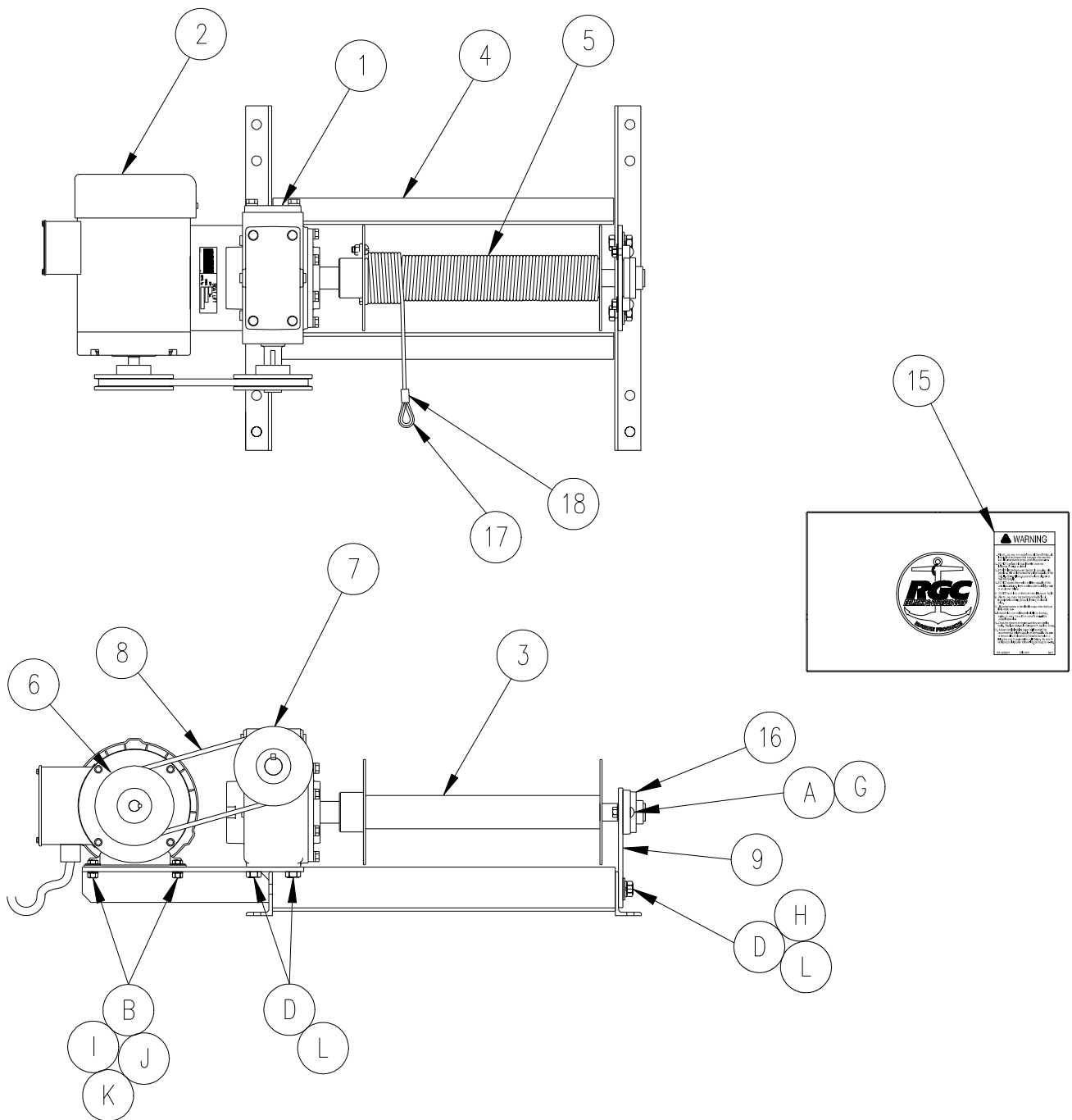

FIG 7-3
Heavy Duty Railway Power Drive Assembly

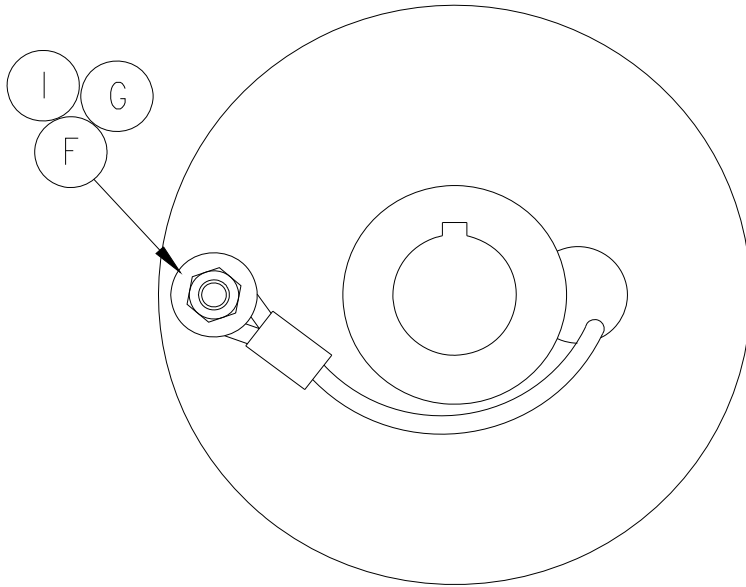

FIG 7-4
Railway Power Drive Drum
Wire Rope Anchoring

TWO YEAR LIMITED WARRANTY

Reimann & Georger Corporation Marine Products

This product is warranted by RGC® Marine Products to the original purchaser to be free from defects in material and workmanship under normal use for a period of two years from the date of purchase.

During the warranty period, and upon proof of purchase, the product will be repaired or replaced (with the same or similar model) at our option, without charge for either parts or labor when serviced at RGC® Marine Products.

Upon completion of repair, the unit will be returned to the customer freight prepaid. The warranty will not apply to this product if it has been misused, abused, or altered.

NEITHER THIS WARRANTY OR ANY OTHER WARRANTY, EXPRESS OR IMPLIED, INCLUDING IMPLIED WARRANTIES OF MERCHANTABILITY, SHALL EXTEND BEYOND THE WARRANTY PERIOD. NO RESPONSIBILITY IS ASSUMED FOR ANY INCIDENTAL OR CONSEQUENTIAL DAMAGES. SOME STATES DO NOT ALLOW EXCLUSION OR LIMITATION OF INCIDENTAL OR CONSEQUENTIAL DAMAGES, SO THE ABOVE LIMITATIONS OR EXCLUSIONS MAY NOT APPLY TO YOU.

This warranty gives you specific legal rights, and you may also have other rights which vary from state to state.