

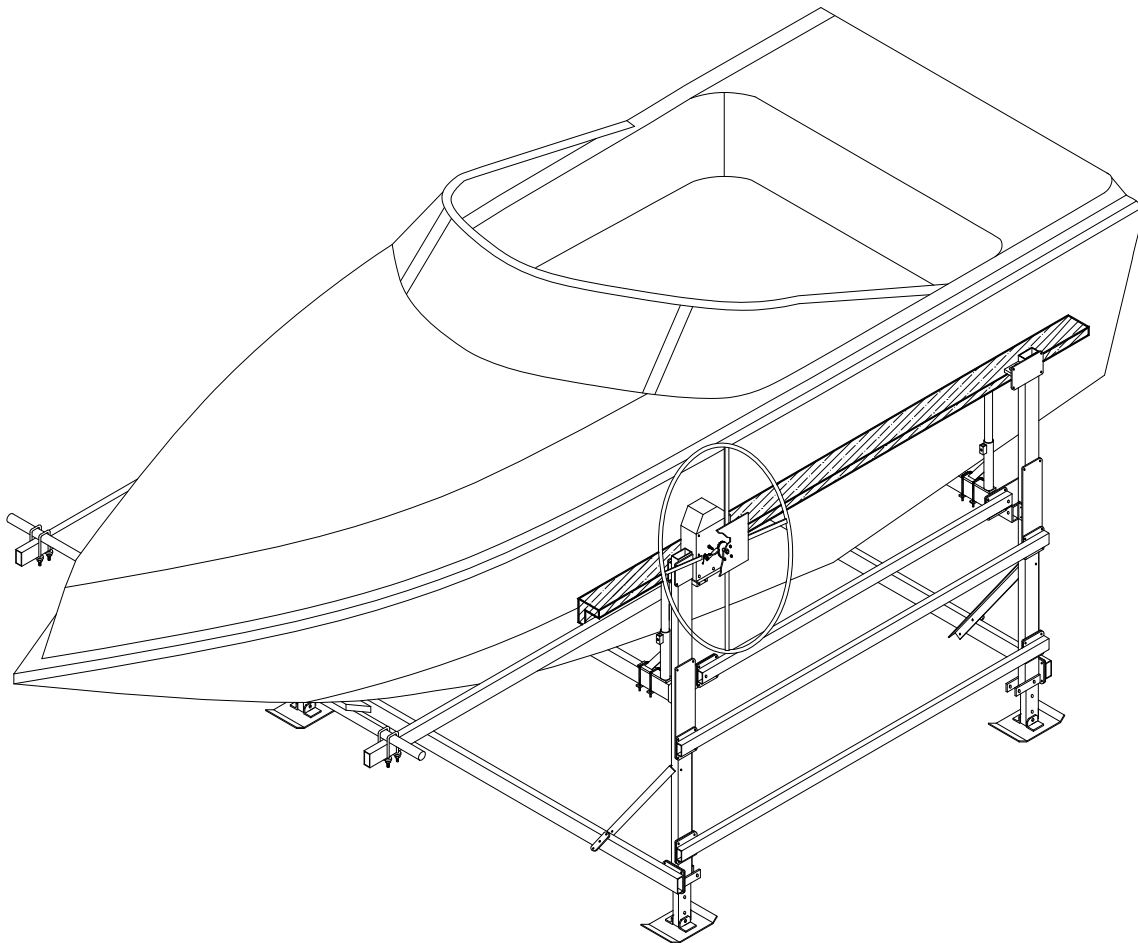

VL GUIDE ON & BOW STOP INSTRUCTIONS



REIMANN & GEORGER CORPORATION
MARINE PRODUCTS
P/N 6112087

BUFFALO, NY
07/18/08

TABLE OF CONTENTS

CHAPTER	TITLE	PAGE
1	SAFETY	1
1.1	Introduction	1
1.2	Safety Definitions	1
1.3	Equipment Safety Labels.....	1
1.4	Safety Rules	1
2	INSTALLATION AND SETUP	3
2.1	Pre-Installation Checks	3
2.2	Prior To Setup	3
2.3	VL Guide On Support Assembly	3
2.4	VL Wood Guide On Assembly	4
2.5	VL Bow Stop Tube Arm	4
2.6	VL Bow Stop Cross Tube and Bumper Assembly	6
2.7	VL Bow Stop and Guide On Adjustments	6
3	INSPECTION AND MAINTENANCE	8
3.1	General Maintenance Rules.....	8
3.2	Annual Inspection.....	8
3.3	Storage Procedure.....	8
4	PARTS LISTS.....	9
4.1	VL 1.6-4K Guide On-Tall with Bow Stop Kit	9
4.2	VL 5K Guide On-Tall with Bow Stop Kit	9
4.3	VL Guide On-Tall with Bow Stop Bundle	10
4.4	VL 6-7K Guide On-Tall with Bow Stop Kit	10
4.5	VL 1.6-4K Guide On-Tall Narrow with Bow Stop Kit.....	10
4.6	VL Guide On-Tall Narrow with Bow Stop Bundle.....	11

LIST OF FIGURES

FIGURE	DESCRIPTION	PAGE
2-1	Guide On Support Tube Assembly.....	4
2-2	Wood Guide On Assembly.....	5
2-3	Bow Stop Tube Arm Assembly	5
2-4	Bow Stop Cross Tube and Bumper Assembly	6
2-5	Bow Stop and Guide On Adjustments.....	7

1 SAFETY

1.1 INTRODUCTION

Your Reimann & Georger Corporation Marine Products VL Guide On and Bow Stop Kit is designed to aid in proper positioning of boats on the lift. Your Guide On and Bow Stop kit is well-designed and well-built. However, like any other equipment, it can malfunction or become hazardous in the hands of an inexperienced and/or untrained user. Therefore, read this manual and your related Vertical Lift manual, and related equipment manuals thoroughly before installing this kit and operating your lift to provide maximum safety for all operating personnel, and to get the maximum benefit from your equipment.

1.2 SAFETY DEFINITIONS

A safety message alerts you to potential hazards that could hurt you or others or cause property damage. The safety messages or signal words for product safety signs are **DANGER**, **WARNING**, and **CAUTION**. Each safety message is preceded by a safety alert symbol and is defined as follows:

DANGER: Indicates an imminently hazardous situation which, if not avoided, **will** cause death or serious injury. This safety message is limited to the most extreme situations.

WARNING: Indicates a potentially hazardous situation which, if not avoided, **could** result in death or serious injury.

CAUTION: Indicates a potentially hazardous situation which, if not avoided, **may** result in minor or moderate injury. It may also be used to alert against unsafe practices and property-damage-only accidents.

1.3 EQUIPMENT SAFETY LABELS

These labels warn you of potential hazards that could cause injury. Read them carefully. If a label comes off or becomes illegible, contact a Reimann & Georger Corporation dealer for a replacement.

1.4 SAFETY RULES



WARNING:

DO NOT INSTALL THIS KIT AND OPERATE THE LIFT WITHOUT READING BOTH THIS MANUAL AND YOUR VERTICAL LIFT MANUAL. FAILURE TO DO THIS CAN LEAD TO EQUIPMENT MISUSE WITH RESULTING DAMAGE AND/OR SERIOUS PERSONAL INJURY. CONTACT YOUR RGC® MARINE DEALER IF YOU HAVE ANY QUESTIONS.

1. Do not install this kit without first replacing any damaged or defective parts.
2. The guide ons and bow stop do not increase the rated capacity of the lift. Never use the lift beyond its rated capacity. This can damage the kit assembly, lift, and/or boat with resulting serious personal injury.
3. Never try using any part of this kit in an application for which it was not designed.
4. Do not weld or otherwise modify any part of this kit. Such alterations may weaken the structural integrity of the lift and void the warranty.
5. Do not try installing the pontoon brackets or bumpers with the weight of the boat on the lift. This can cause equipment damage and/or personal injury.
6. The following precautions must be observed when lifting any part of this equipment:
 - a. Be sure of your footing.
 - b. Bend your knees and lift with your legs.
 - c. Hold the equipment section close to your body when lifting.
7. After the guide ons and bow stop are installed, the safety checks in Steps 8 through 25 must be performed on your lift prior to operation. Details on these checks are given in your vertical lift manual.
8. Before allowing anyone to operate the lift, be sure they fully understand the proper operating procedure.

9. Do not operate the lift under the influence of drugs, alcohol, or medication.
10. Keep people and pets clear during operation of the lift.
11. Keep fingers and clothing clear of all moving parts.
12. Never allow people in the boat any time it is suspended above the water on the platform.



WARNING:

DO NOT STAND OR WALK ON THE PLATFORM WHILE IT IS IN ANY RAISED POSITION. THIS CAN CAUSE SERIOUS PERSONAL INJURY.

13. Do not allow anyone to swim or play under, near or on the lift at any time.
14. Ensure that all bolts and nuts are fastened securely on both this kit and the lift prior to operation.
15. Ensure that the frame is level and square.
16. Completely remove any user or dealer installed locking devices before operating the lift.
17. The boat must be secured on the lift before raising or lowering. Failure to do this can cause equipment damage and/or serious personal injury.
18. Check the lift periodically for frayed cables and/or binding pulleys. If any pulley binds, replace it immediately.
19. Do not try making any adjustments on the lift during operation.
20. Contact your dealer if the winch mechanism fails to perform as described in the Operation chapter of your vertical lift manual.
21. Never tamper with the winch mechanism. This can cause equipment damage.
22. When using a direct drive or motorized friction drive, understand the use of all controls and connections provided with it.



WARNING:

ALL ELECTRIC DRIVES MUST BE INSTALLED AND INSPECTED BY A CERTIFIED ELECTRICIAN IN ACCORDANCE WITH LOCAL ELECTRICAL CODES. THIS INSTALLATION MUST INCLUDE A PROPERLY WORKING GROUND FAULT CIRCUIT INTERRUPTER. (G.F.C.I.)

23. Never use the lift to hang or store any auxiliary equipment such as boating hardware.
24. The handwheel or power drive must turn clockwise when raising the platform and counter-clockwise when lowering the platform. If the platform operates in the reverse sense, you have reeved the winch incorrectly. You **MUST** follow the winch reeving instructions in your vertical lift manual to prevent equipment damage and/or personal injury. The brake pawl must click during platform raising, indicating that the brake is operative. The self-activating brake mechanism must provide a controlled lowering of the platform.



WARNING:

NEVER RELEASE THE BRAKE PAWL OF THE WINCH. THIS CAN TRIGGER AN UNCONTROLLED SPIN-DOWN OR “FREEWHEEL” OF THE HANDWHEEL. IF FREEWHEELING OCCURS, NEVER TRY TO STOP IT AS THIS CAN CAUSE SERIOUS PERSONAL INJURY.

25. Padlock the handwheel to the post or lock out your power drive to prevent unauthorized use when your lift is left unattended.

2 INSTALLATION AND SET UP

2.1 PRE-INSTALLATION CHECKS

1. Do not assemble this kit or any other component of the lift if any part appears to be damaged.
2. Do not weld or other wise modify any portion of the lift. Such alterations may weaken the structural integrity of the lift and void the warranty.
3. This product has been supplied with stainless steel hardware to protect against a harsh marine environment and provide outstanding performance. Due to the chemistry and surface condition of stainless steel, there is a natural tendency for the hardware to “gall, lock up, or seize” during assembly. To prevent this from occurring, it is **highly recommended** that the anti-seize supplied in the hardware bag be applied to the mating surfaces of all stainless steel fasteners before assembly. Lubricants containing molybdenum disulfide, graphite, mica or talc may also be used.



CAUTION:

DO NOT EXCEED THE MAXIMUM TORQUE RATING ON ALL BOLTS OF 20 FT-LBS.



WARNING:

FAILURE TO APPLY A SUITABLE LUBRICANT TO THE MATING SURFACES OF STAINLESS STEEL THREADED FASTENERS MAY CAUSE GALLING AND/OR SEIZING OF ASSEMBLY.

2.2 PRIOR TO SETUP

The part reference letters used in the subassembly drawings of sections 2.3 through 2.7 are the same as those shown in Figure 2-1 through Figure 2-5 and listed in the parts lists of Chapter 4.

2.3 GUIDE ON SUPPORT ASSEMBLY

1. (Refer to Figure 2-1) Position a VL Guide On Support (1), on the Load Tube (X), with the diagonal brace facing the center of the Load Tube. Insert two 3/8” square bend u-bolts (8,9, or 10), one over the end of the support mounting plate and, the other square bend u-bolt is then inserted through the triangular space closest to the round support tube. Place a Clamp (3 or K), onto each u-bolt and loosely attach a 3/8” flat washer (J), then a 3/8” lock washer (L), and finally a 3/8” hex nut (I), to each side of both u-bolts. **(DO NOT TIGHTEN AT THIS TIME).**
2. Position a VL Guide On Upper Tube assembly (2), inside the VL Guide On Support tube. Insert a 1/2” square nut (7), into the square housing on the support assembly. Hold nut in place by threading a 1/2” Hex Head Cap Screw (HHCS) (6). **(DO NOT TIGHTEN AT THIS TIME).** Repeat steps one and two for the other three support assemblies.

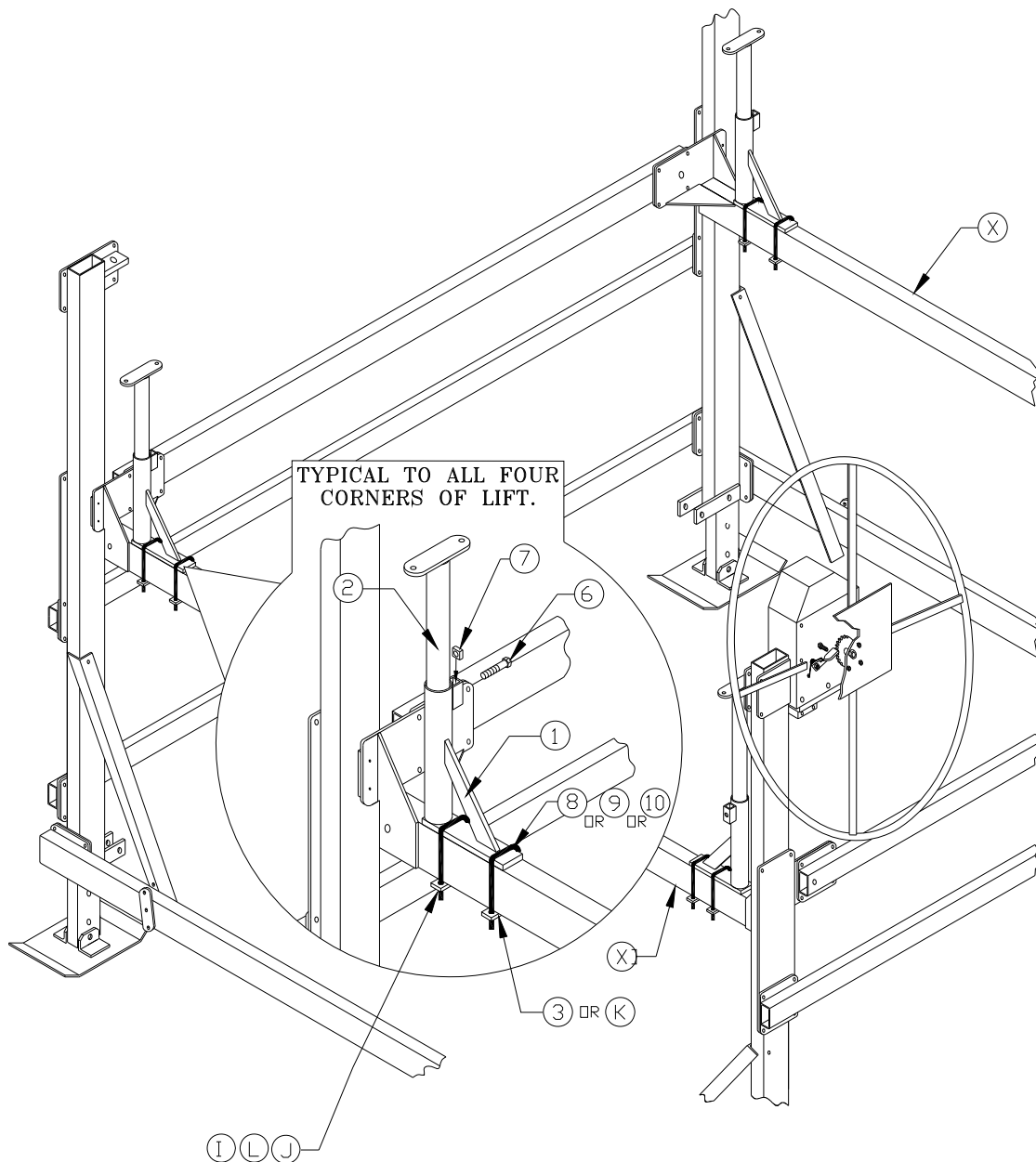

Figure 2-1.
Guide On Support Tube installation

2.4 WOOD GUIDE ON ASSEMBLY

1. (Refer to Figure 2-2) Position a Bow Stop Guide On (4), on top of the Upper Tube assembly so that the aluminum channel (pre-assembled to wood) rests on top of both Upper Tube mounting plates (2).
2. Insert two spring nuts (F), into the channel as shown and turn to lock in place on channel ridge. Compress spring to slide into position. Insert two 3/8" HHCS (5), through the mounting plate and into the spring nuts. **(DO NOT TIGHTEN AT THIS TIME)**. Repeat for the other end of the Guide On.
3. Repeat steps one and two for second Guide On. Then secure all fasteners for Guide Ons and Support assemblies.

2.5 BOW STOP TUBE ARM ASSEMBLY

1. (Refer to Figure 2-3) Position the right hand Bow Stop Tube Arm (A) mounting angles facing the inside of the lift and against the bottom of the guide on aluminum channel.

2. Insert four spring nuts (F), into the channel as shown and turn to lock in place on channel ridge. Compress spring to slide into position.
3. Insert four 3/8" HHCS (E) through the mounting angles and into the spring nuts. (**DO NOT TIGHTEN AT THIS TIME**).
4. Repeat steps one through three for the left hand Bow Stop Tube Arm (B). Then tighten fasteners securely.

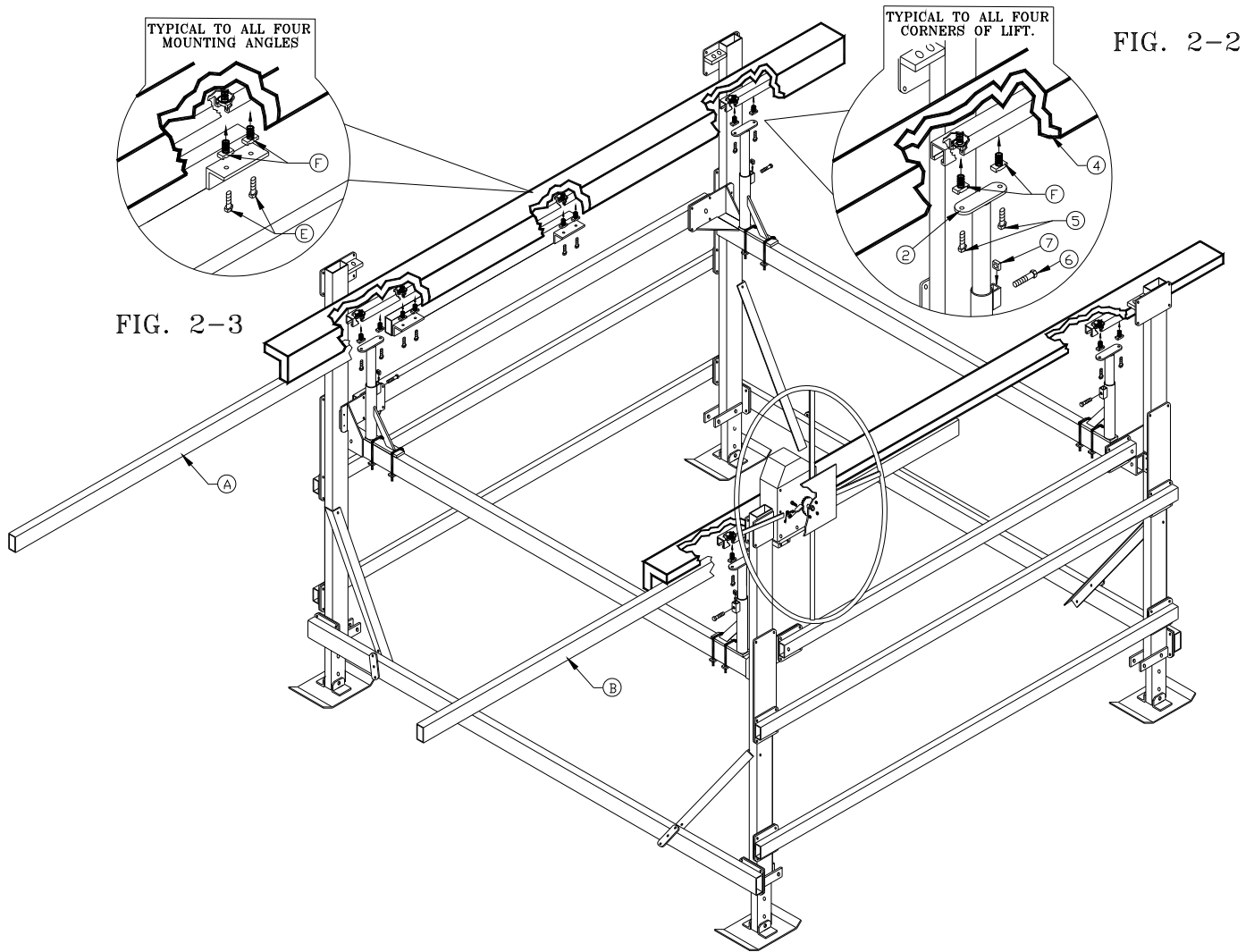

**Figure 2-2 & Figure 2-3.
Guide On & Bow Stop Tube Arm installation**

2.6 BOW STOP CROSS TUBE AND BUMPER ASSEMBLY

1. (Refer to Figure 2-4) Position the Bow Stop Cross Tube (C) between both Bow Stop Arms, near the end furthest from the lift. Place the square bend u-bolts (G), over the top of the Cross Tube on both sides of the Bow Stop Tube Arm. Place a 2" two hole plate (3), on each u-bolt. Then loosely attach a 3/8" flat washer (J), 3/8" split lock washer (L), and a 3/8" hex nut (I) to each side of both u-bolts. (**DO NOT TIGHTEN AT THIS TIME**). Repeat for the other end of Cross Tube.
2. Position the Bow Stop Carpeted Bumper (D), centered and on top of the Bow Stop Cross Tube with the carpets seam facing the cross tube. Place a 3/8 u-bolt (H) around the cross tube, then through the bumper. Install a 3/8" flat washer (J), 3/8" split lock washer (L), and a 3/8" hex nut (I), to both ends of the u-bolt. (**DO NOT TIGHTEN AT THIS TIME**). Repeat for other end of bumper and tighten all Bow Stop Arm, Cross Tube, and, Bumper fasteners.

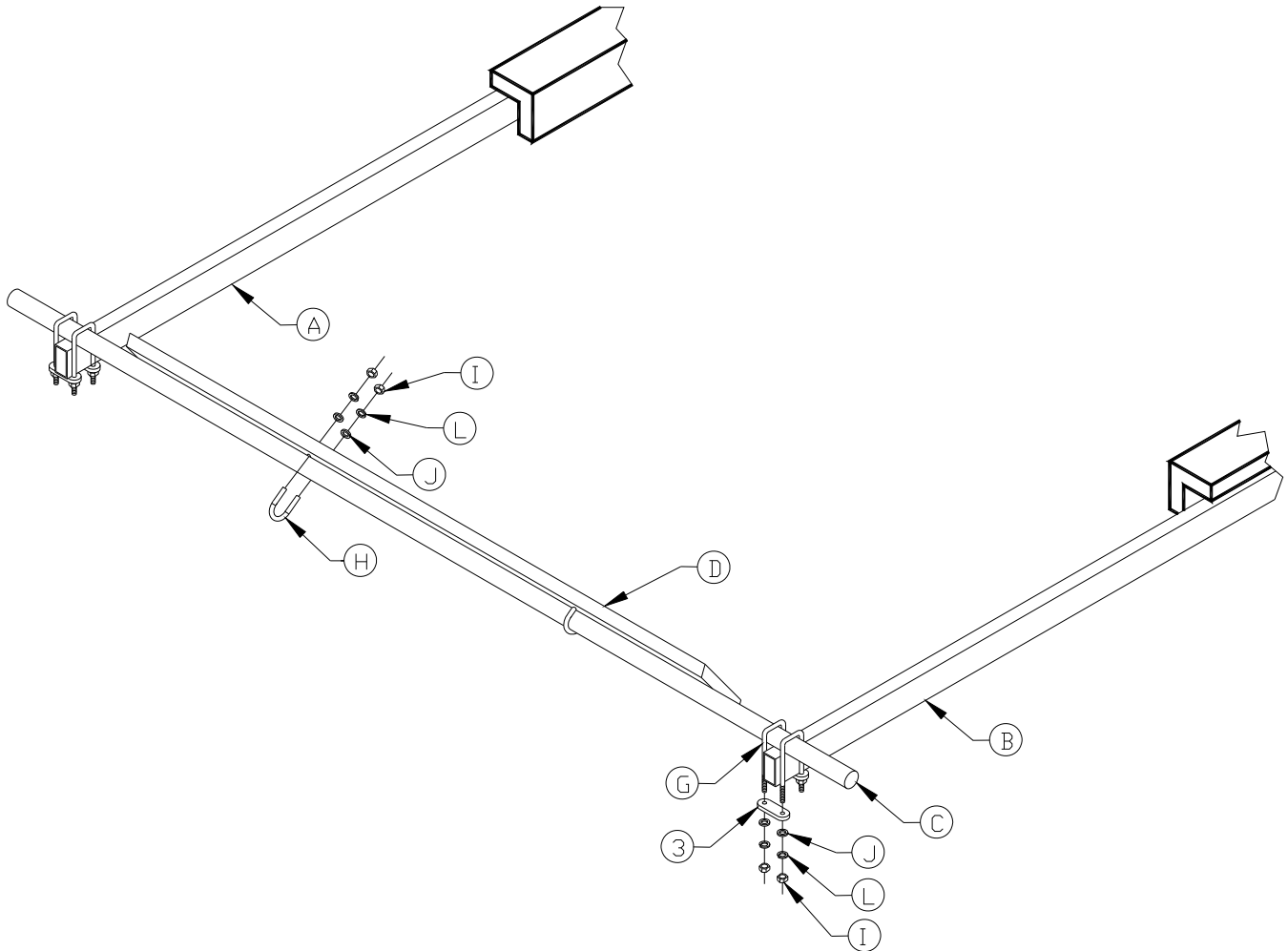

Figure 2-4.
Bow Stop Cross Tube and Bumper installation

2.7 BOW STOP AND GUIDE ON ADJUSTMENTS

1. (Refer to Figure 2-5) Loosen u-bolt nuts (I) on load tubes and at cross tube to adjust distance between Wood Guide Ons, to best suit boat width and wave conditions. Retighten only the load tube nuts at this time.

NOTE: ADJUST FOR MORE SPACE BETWEEN GUIDE ON & HULL IN AREAS WITH CHOPPY WATER.

2. Loosen Hex Head Cap Screw (6) at each corner of the lift to adjust Wood Guide On height to best suit boat. Retighten Hex Screws when finished.

NOTE: ADJUST GUIDE ONS TO AVOID CONTACT WITH ANY GRAPHICS OR DECALS ON BOAT HULL.

3. Rotate Bow Stop Bumper to make full contact with hull of boat and tighten cross tube u-bolt nuts.
4. Loosen Hex Head Cap Screws (E) holding Bow Stop Arms. Slide arms to adjust Bow Stop Bumper for length of boat. Making sure motor does not contact lift.

NOTE: ADJUST BOW STOP SO BOATS WEIGHT REMAINS CENTERED ON LIFT TO AVOID DAMAGE TO LIFT OR BOAT.

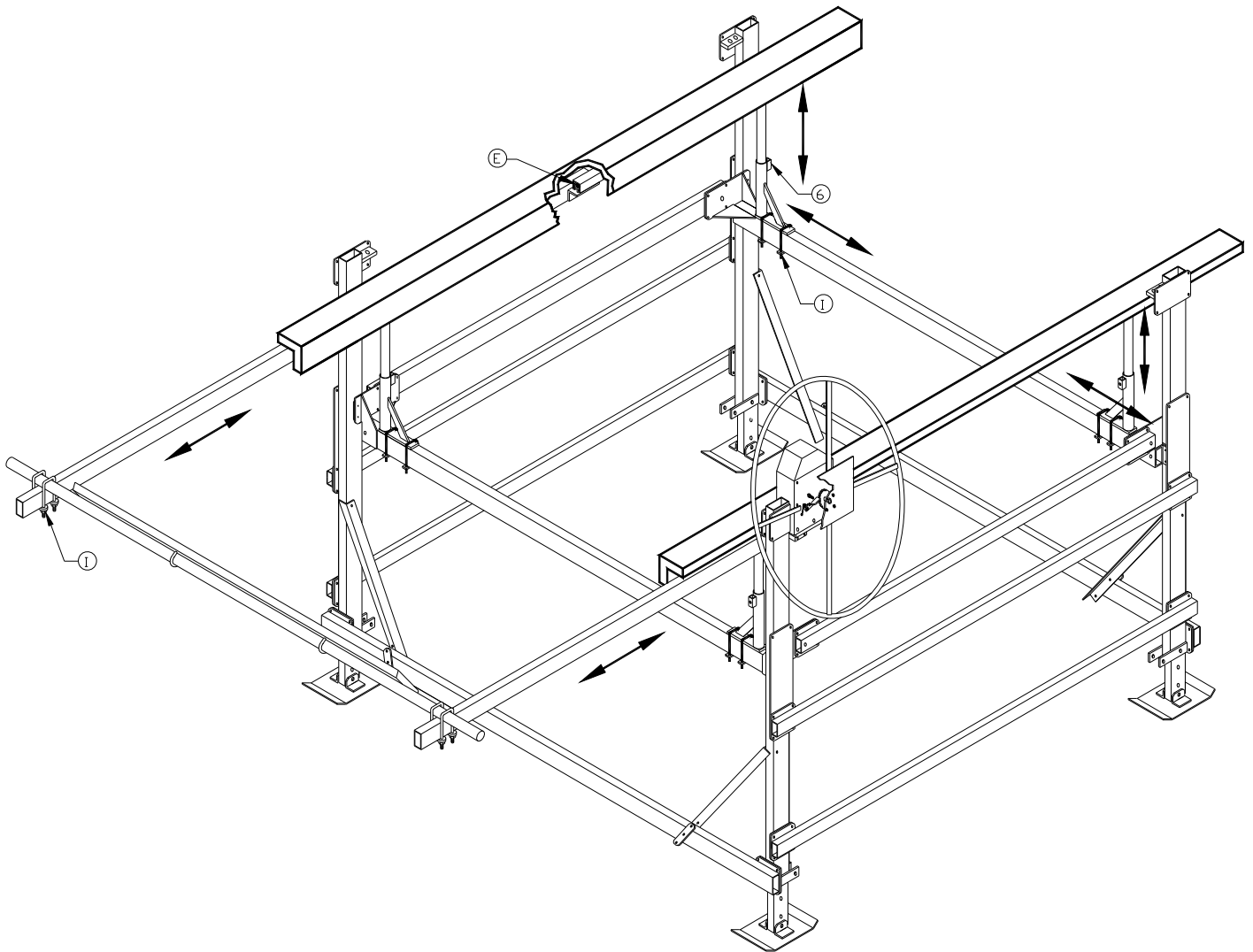

Figure 2-5.
Bow Stop and Guide On adjustments

3 INSPECTION AND MAINTENANCE

3.1 GENERAL MAINTENANCE RULES

1. Do not allow persons other than authorized service personnel to repair this equipment.
2. Inspect bumpers and guide ons regularly for deterioration. Replace them immediately if they are worn.
3. Do not weld or otherwise modify the lift. Such alterations may weaken the structural integrity of the lift and invalidate your warranty.
4. Completely lower the lift before performing any type of maintenance or repair.



WARNING:

NEVER ALLOW ANYBODY TO WORK IN OR ON THE BOAT WHEN IT IS SUSPENDED ABOVE THE WATER ON THE LIFT. IF THE HANDWHEEL ON THE WINCH SHOULD START FREEWHEELING, DEATH OR SERIOUS INJURY COULD RESULT.

IF FREEWHEELING STARTS, NEVER TRY TO STOP IT. ALTHOUGH A SPIN DOWN OR "FREEWHEELING" CAN CAUSE LIFT OR BOAT DAMAGE, TRYING TO STOP FREEWHEELING CAN CAUSE SERIOUS PERSONAL INJURY.

3.2 ANNUAL INSPECTION

At least once a year, the lift must be thoroughly inspected using the following procedure.



WARNING:

DO NOT ALLOW ANYBODY TO USE THE LIFT UNTIL THIS MAINTENANCE IS COMPLETED.

1. Tighten all bolts.
2. Check all carpeted wood bumpers and wood guide ons for any damage, deterioration, or excessive wear. If any is found, replace them immediately.
3. Check frame thoroughly for defects.

3.3 STORAGE PROCEDURE

1. Position boat on platform so the lower unit of the motor is against the optional motor stop (if used).
2. A boat that has water in it from a rain storm could exceed the recommended weight capacity for the lift. Just 1 gallon of water weighs over 8 pounds. Be sure to remove the plug while the boat is up on the lift. Make sure you replace the plug prior to launching your boat.
3. Protect your lift as far as possible from damage caused by environmental factors such as airborne fallout, chemicals, tree sap, and weather hazards.
4. Never use the lift to hang or store any auxiliary equipment such as boating hardware.
5. Do not allow anyone to swim or play near the lift at any time.
6. Padlock the handwheel to the post and disconnect the power to any electric motor when your boat lift is unattended. Never assume you will find the lift in the same condition that you left it.

4 PARTS LISTS

Each reference number or letter in the following parts lists can be matched with the reference number or letter referred to in the illustrations of Chapter 2, Installation and Setup.



WARNING:

FAILURE TO APPLY A SUITABLE LUBRICANT TO THE MATING SURFACES OF STAINLESS STEEL THREADED FASTENERS MAY CAUSE GALLING AND/OR SEIZING OF ASSEMBLY.

4.1 #3681620 VL WOOD GUIDE ON-TALL WITH BOW STOP KIT 1.6-4K

REF #	PART #	QTY	DESCRIPTION
	3679815	1	VL GUIDE ON-TALL SS CARTON OF PARTS 1.6-4K consisting of:
2	3608028	4	GUIDE ON UPPER TUBE ASSEMBLY 12"
1	3608025	4	VL GUIDE ON SUPPORT ASSEMBLY 21"
	3602901	1	VL GUIDE ON BAG OF BOLTS 1.6-4K consisting of:
3	3603835	8	TWO HOLE PLATE 2"
F	5805898	8	3/8 SPRING NUT
L	5806243	16	3/8 SPLIT LOCKWASHER
5	5896248	8	3/8 X 1-1/4 HEX HEAD CAP SCREW
6	5896282	4	1/2 X 1-1/2 HEX HEAD CAP SCREW
I	5803638	16	3/8 HEX NUT –SILICON BRONZE
7	5896385	4	1/2 SQUARE NUT
J	5896406	16	3/8 SAE FLAT WASHER
8	5898100	8	3/8 X 2-1/8 X 5-5/8 SQUARE BEND U-BOLT
	3682202	1	VL GUIDE ON WITH BOW STOP SS BUNDLE (SEE SEC. 4.3)

4.2 #3681625 VL WOOD GUIDE ON-TALL WITH BOW STOP KIT 5K

REF #	PART #	QTY	DESCRIPTION
	3679810	1	VL GUIDE ON-TALL CARTON OF PARTS 5K consisting of:
2	3608028	4	GUIDE ON UPPER TUBE ASSEMBLY 12"
1	3608025	4	VL GUIDE ON SUPPORT ASSEMBLY 21"
	3602910	1	GUIDE ON BAG OF BOLTS 5K consisting of:
K	3606921	8	TWO HOLE PLATE 3"
F	5805898	8	3/8 SPRING NUT
L	5806243	16	3/8 SPLIT LOCKWASHER
9	5895900	8	3/8 X 3-1/8 X 6-5/8 SQUARE BEND U-BOLT
5	5896248	8	3/8 X 1-1/4 HEX HEAD CAP SCREW
6	5896282	4	1/2 X 1-1/2 HEX HEAD CAP SCREW
I	5803638	16	3/8 HEX NUT –SILICON BRONZE
7	5896385	4	1/2 SQUARE NUT
J	5896406	16	3/8 SAE FLAT WASHER
	3682202	1	VL GUIDE ON WITH BOW STOP SS BUNDLE (SEE SEC. 4.3)

4.3 #3682202 VL WOOD GUIDE ON WITH BOW STOP BUNDLE

REF #	PART #	QTY	DESCRIPTION
4	3602196	2	VL GUIDE ON FOR BOW STOP
A	3602184	1	BOW STOP TUBE ARM RIGHT HAND
B	3602183	1	BOW STOP TUBE ARM LEFT HAND
D	3602179	1	BOW STOP WOOD BUMPER
C	3602169	1	BOW STOP CROSS TUBE
	3682253	1	VL GUIDE ON WITH BOW STOP SS BAG OF BOLTS consisting of:
3	3603835	4	2-HOLE PLATE 2"
G	5803000	4	3/8 X 2-1/16 X 6-5/8 SQUAR BEND U-BOLT
F	5805898	8	3/8 SPRING NUT
L	5806243	12	3/8 SPLIT LOCKWASHER
H	5896080	2	3/8 X 4 STANDARD U-BOLT
E	5896249	8	3/8 X 1-1/2 HEX HEAD CAP SCREW
I	5803638	12	3/8 HEX NUT –SILICON BRONZE

4.4 #3681635 VL WOOD GUIDE ON-TALL WITH BOW STOP KIT 6-7K

REF #	PART #	QTY	DESCRIPTION
	3679830	1	VL GUIDE ON-TALL CARTON OF PARTS 6-7K consisting of:
2	3608028	4	GUIDE ON UPPER TUBE ASSEMBLY 12"
1	3608025	4	VL GUIDE ON SUPPORT ASSEMBLY 21"
	3602930	1	VL GUIDE ON BAG OF BOLTS 6-7K consisting of:
3	3603835	4	TWO HOLE PLATE 2"
K	3606921	4	TWO HOLE PLATE 3"
F	5805898	8	3/8 SPRING NUT
L	5806243	16	3/8 SPLIT LOCKWASHER
10	5895901	4	3/8 X 3-1/8 X 8-5/8 SQUARE BEND U-BOLT
11	5895905	4	3/8 X 2-1/8 X 8-5/8 SQUARE BEND U-BOLT
5	5896248	8	3/8 X 1-1/4 HEX HEAD CAP SCREW
6	5896282	4	1/2 X 1-1/2 HEX HEAD CAP SCREW
I	5803638	16	3/8 HEX NUT –SILICON BRONZE
7	5896385	4	1/2 SQUARE NUT
J	5896406	16	3/8 SAE FLAT WASHER
	3682202	1	VL GUIDE ON WITH BOW STOP SS BUNDLE (SEE SEC. 4.3)

4.5 #3681640 VL WOOD GUIDE ON-TALL NARROW WITH BOW STOP KIT 1.6-4K

REF #	PART #	QTY	DESCRIPTION
	3679815	1	VL GUIDE ON-TALL SS CARTON OF PARTS 1.6-4K consisting of:
2	3608028	4	GUIDE ON UPPER TUBE ASSEMBLY 12"
1	3608025	4	VL GUIDE ON SUPPORT ASSEMBLY 21"
	3602901	1	VL GUIDE ON BAG OF BOLTS 1.6-4K consisting of:
3	3603835	8	TWO HOLE PLATE 2"
F	5805898	8	3/8 SPRING NUT
L	5806243	16	3/8 SPLIT LOCKWASHER
5	5896248	8	3/8 X 1-1/4 HEX HEAD CAP SCREW
6	5896282	4	1/2 X 1-1/2 HEX HEAD CAP SCREW
I	5803638	16	3/8 HEX NUT –SILICON BRONZE
7	5896385	4	1/2 SQUARE NUT
J	5896406	16	3/8 SAE FLATWASHER
8	5898100	8	3/8 X 2-1/8 X 5-5/8 SQUARE BEND U-BOLT
	3682210	1	VL GUIDE ON NARROW WITH BOW STOP SS BUNDLE (SEE SEC.

4.6 #3682210 VL WOOD GUIDE ON NARROW WITH BOW STOP BUNDLE

REF #	PART #	QTY	DESCRIPTION
4	3602191	2	VL GUIDE ON NARROW FOR BOW STOP
A	3602184	1	BOW STOP TUBE ARM RIGHT HAND
B	3602183	1	BOW STOP TUBE ARM LEFT HAND
D	3602179	1	BOW STOP WOOD BUMPER
C	3602169	1	BOW STOP CROSS TUBE
	3682253	1	VL GUIDE ON WITH BOW STOP SS BAG OF BOLTS consisting of:
3	3603835	4	2-HOLE PLATE 2"
G	5803000	4	3/8 X 2-1/16 X 6-5/8 SQUAR BEND U-BOLT
F	5805898	8	3/8 SPRING NUT
L	5806243	12	3/8 SPLIT LOCKWASHER
H	5896080	2	3/8 X 4 STANDARD U-BOLT
E	5896249	8	3/8 X 1-1/2 HEX HEAD CAP SCREW
I	5803638	12	3/8 HEX NUT –SILICON BRONZE
J	5896406	12	3/8 SAE FLAT WASHER

4.7 VL WOOD GUIDE ON- X-TALL WITH BOW STOP KIT 10K

REF #	PART #	QTY	DESCRIPTION
	3610250	1	VL GUIDE ON X-TALL CARTON OF PARTS 10K consisting of:
2	3610920	4	VL GUIDE ON HD SUPPORT ASSEMBLY 21"
1	3610925	4	GUIDE ON HD UPPER TUBE ASSEMBLY 21"
	3610220	1	GUIDE ON BAG OF BOLTS 10K consisting of:
K	3606921	8	TWO HOLE PLATE 3"
F	5805898	8	3/8 SPRING NUT
L	5806243	16	3/8 SPLIT LOCKWASHER
9	5895901	8	3/8 X 3-1/8 X 8-5/8 SQUARE BEND U-BOLT
5	5896248	8	3/8 X 1-1/4 HEX HEAD CAP SCREW
6	5896282	4	1/2 X 1-1/2 HEX HEAD CAP SCREW
I	5803638	16	3/8 HEX NUT –SILICON BRONZE
7	5896385	4	1/2 SQUARE NUT
J	5896406	16	3/8 SAE FLAT WASHER
	3610241	1	VL GUIDE ON WITH BOW STOP SS BUNDLE 10K (SEE SEC. 4.10)

4.8 VL WOOD GUIDE ON 2X-TALL WITH BOW STOP KIT 10K

REF #	PART #	QTY	DESCRIPTION
	3610251	1	VL GUIDE ON 2X-TALL CARTON OF PARTS 10K consisting of:
2	3610930	4	VL GUIDE ON HD SUPPORT ASSEMBLY 30"
1	3610925	4	GUIDE ON HD UPPER TUBE ASSEMBLY 21"
	3610220	1	GUIDE ON BAG OF BOLTS 10K consisting of:
K	3606921	8	TWO HOLE PLATE 3"
F	5805898	8	3/8 SPRING NUT
L	5806243	16	3/8 SPLIT LOCKWASHER
9	5895901	8	3/8 X 3-1/8 X 8-5/8 SQUARE BEND U-BOLT
5	5896248	8	3/8 X 1-1/4 HEX HEAD CAP SCREW
6	5896282	4	1/2 X 1-1/2 HEX HEAD CAP SCREW
I	5803638	16	3/8 HEX NUT –SILICON BRONZE
7	5896385	4	1/2 SQUARE NUT
J	5896406	16	3/8 SAE FLAT WASHER
	3610241	1	VL GUIDE ON WITH BOW STOP SS BUNDLE 10K (SEE SEC. 4.10)

4.9 VL WOOD GUIDE ON 3X-TALL WITH BOW STOP KIT 10K

REF #	PART #	QTY	DESCRIPTION
	3610252	1	VL GUIDE ON 3X-TALL CARTON OF PARTS 10K consisting of:
2	3610930	4	VL GUIDE ON HD SUPPORT ASSEMBLY 30"
1	3610935	4	GUIDE ON HD UPPER TUBE ASSEMBLY 30"
	3610220	1	GUIDE ON BAG OF BOLTS 10K consisting of:
K	3606921	8	TWO HOLE PLATE 3"
F	5805898	8	3/8 SPRING NUT
L	5806243	16	3/8 SPLIT LOCKWASHER
9	5895901	8	3/8 X 3-1/8 X 8-5/8 SQUARE BEND U-BOLT
5	5896248	8	3/8 X 1-1/4 HEX HEAD CAP SCREW
6	5896282	4	1/2 X 1-1/2 HEX HEAD CAP SCREW
I	5803638	16	3/8 HEX NUT –SILICON BRONZE
7	5896385	4	1/2 SQUARE NUT
J	5896406	16	3/8 SAE FLAT WASHER
	3610241	1	VL GUIDE ON WITH BOW STOP SS BUNDLE 10K (SEE SEC. 4.10)

4.10 #3610241 VL WOOD GUIDE ON WITH BOW STOP SS BUNDLE 10K

REF #	PART #	QTY	DESCRIPTION
4	3610480	1	VL GUIDE ON FOR BOW STOP RH 10K
	3610475	1	VL GUIDE ON FOR BOW STOP LH 10K
A	3610490	1	BOW STOP TUBE ARM RIGHT HAND 144" 10K
B	3610485	1	BOW STOP TUBE ARM LEFT HAND 144" 10K
D	3602179	1	BOW STOP WOOD BUMPER
C	3610724	1	BOW STOP CROSS TUBE 144"
	3682253	1	VL GUIDE ON WITH BOW STOP SS BAG OF BOLTS consisting of:
3	3603835	4	2-HOLE PLATE 2"
G	5803000	4	3/8 X 2-1/16 X 6-5/8 SQUAR BEND U-BOLT
F	5805898	8	3/8 SPRING NUT
L	5806243	12	3/8 SPLIT LOCKWASHER
H	5896080	2	3/8 X 4 STANDARD U-BOLT
E	5896249	8	3/8 X 1-1/2 HEX HEAD CAP SCREW
I	5803638	12	3/8 HEX NUT –SILICON BRONZE
J	5896406	12	3/8 SAE FLAT WASHER

TWO YEAR LIMITED WARRANTY

Reimann & Georger Corporation Marine Products

This product is warranted by RGC® Marine Products to the original purchaser to be free from defects in material and workmanship under normal use for a period of two years from the date of purchase.

During the warranty period, and upon proof of purchase, the product will be repaired or replaced (with the same or similar model) at our option, without charge for either parts or labor when serviced at RGC® Marine Products.

Upon completion of repair, the unit will be returned to the customer freight prepaid. The warranty will not apply to this product if it has been misused, abused, or altered.

NEITHER THIS WARRANTY OR ANY OTHER WARRANTY, EXPRESS OR IMPLIED, INCLUDING IMPLIED WARRANTIES OF MERCHANTABILITY, SHALL EXTEND BEYOND THE WARRANTY PERIOD. NO RESPONSIBILITY IS ASSUMED FOR ANY INCIDENTAL OR CONSEQUENTIAL DAMAGES. SOME STATES DO NOT ALLOW EXCLUSION OR LIMITATION OF INCIDENTAL OR CONSEQUENTIAL DAMAGES, SO THE ABOVE LIMITATIONS OR EXCLUSIONS MAY NOT APPLY TO YOU.

This warranty gives you specific legal rights, and you may also have other rights which vary from state to state.