

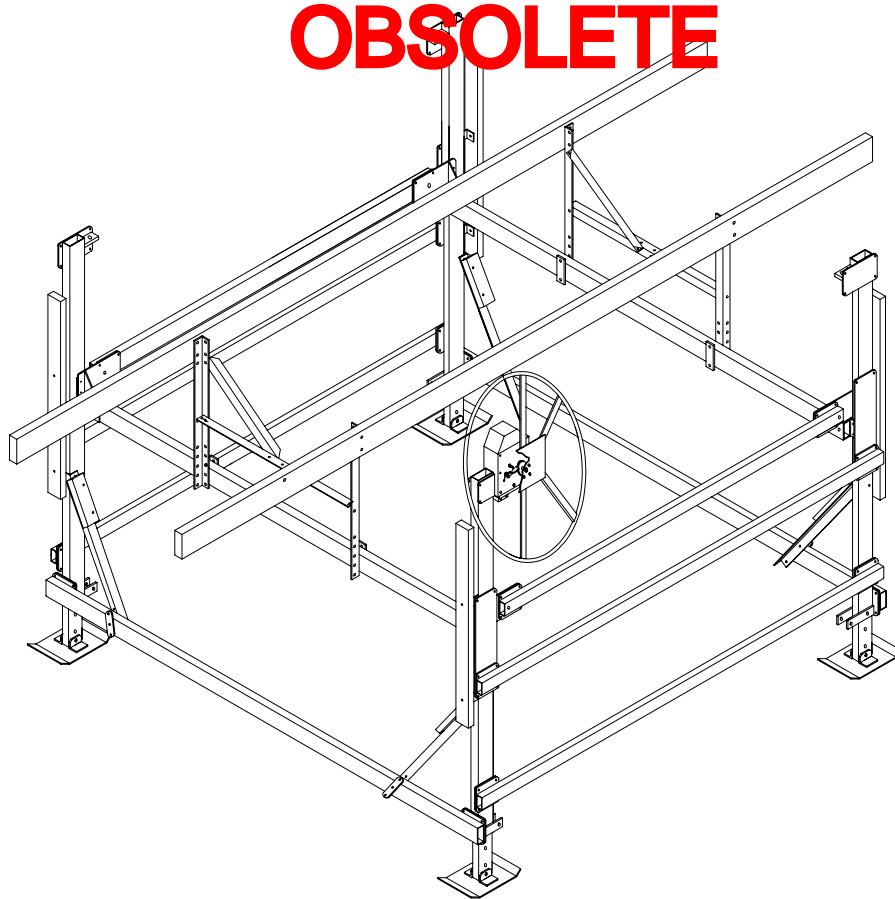

# VL PONTON DECK BRACKET & BUMPER INSTRUCTIONS

**OBSOLETE**



REIMANN & GEORGER CORPORATION  
MARINE PRODUCTS  
P/N 6112130

BUFFALO, NY  
07/11/07

## TABLE OF CONTENTS

CHAPTER	TITLE	PAGE
<b>1</b>	<b>SAFETY .....</b>	<b>1</b>
1.1	Introduction .....	1
1.2	Safety Definitions .....	1
1.3	Equipment Safety Labels.....	1
1.4	Safety Rules .....	1
<b>2</b>	<b>INSTALLATION AND SETUP .....</b>	<b>3</b>
2.1	Pre-Installation Checks .....	3
2.2	Prior To Setup .....	3
2.3	Pontoon Bracket Assembly .....	3
2.4	Wood Bunk Assembly .....	4
2.5	Upper Bumper Assembly .....	5
2.6	Lower Bumper Assembly .....	6
<b>3</b>	<b>INSPECTION AND MAINTENANCE .....</b>	<b>8</b>
3.1	General Maintenance Rules.....	8
3.2	Annual Inspection.....	8
3.3	Storage Procedure.....	8
<b>4</b>	<b>PARTS LISTS.....</b>	<b>9</b>
4.1	VL 1.6-4K Pontoon Deck Bracket & Bumper Kit .....	9
4.2	VL 4.6-5K Pontoon Deck Bracket & Bumper Kit .....	10

## LIST OF FIGURES

FIGURE	DESCRIPTION	PAGE
2-1	Pontoon Bracket Assembly .....	4
2-2	Wood Bumper Assembly.....	5
2-3	Upper Bumper Assembly .....	6
2-4	Lower Bumper Assembly.....	7

# 1 SAFETY

## 1.1 INTRODUCTION

Your Reimann & Georger Corporation Marine Products VL Pontoon Deck Bracket and Bumper Kit is designed to raise pontoon boats from under the deck. Your pontoon kit is well-designed and well-built. However, like any other equipment, it can malfunction or become hazardous in the hands of an inexperienced and/or untrained user. Therefore, read this manual and your related Vertical Lift manual, and related equipment manuals thoroughly before installing this kit and operating your lift to provide maximum safety for all operating personnel, and to get the maximum benefit from your equipment.

## 1.2 SAFETY DEFINITIONS

A safety message alerts you to potential hazards that could hurt you or others or cause property damage. The safety messages or signal words for product safety signs are **DANGER**, **WARNING**, and **CAUTION**. Each safety message is preceded by a safety alert symbol and is defined as follows:

**DANGER:** Indicates an imminently hazardous situation which, if not avoided, **will** cause death or serious injury. This safety message is limited to the most extreme situations.

**WARNING:** Indicates a potentially hazardous situation which, if not avoided, **could** result in death or serious injury.

**CAUTION:** Indicates a potentially hazardous situation which, if not avoided, **may** result in minor or moderate injury. It may also be used to alert against unsafe practices and property-damage-only accidents.

## 1.3 EQUIPMENT SAFETY LABELS

These labels warn you of potential hazards that could cause injury. Read them carefully. If a label comes off or becomes illegible, contact a Reimann & Georger Corporation dealer for a replacement.

## 1.4 SAFETY RULES



### **WARNING:**

**DO NOT INSTALL THIS KIT AND OPERATE THE LIFT WITHOUT READING BOTH THIS MANUAL AND YOUR VERTICAL LIFT MANUAL. FAILURE TO DO THIS CAN LEAD TO EQUIPMENT MISUSE WITH RESULTING DAMAGE AND/OR SERIOUS PERSONAL INJURY. CONTACT YOUR RGC® MARINE DEALER IF YOU HAVE ANY QUESTIONS.**

1. Do not install this kit without first replacing any damaged or defective parts.
2. The pontoon brackets and bumpers do not increase the rated capacity of the lift. Never use the lift beyond its rated capacity. This can damage the kit assembly, lift, and/or boat with resulting serious personal injury.
3. Never try using any part of this kit in an application for which it was not designed.
4. Do not weld or otherwise modify any part of this kit. Such alterations may weaken the structural integrity of the lift and void the warranty.
5. Do not try installing the pontoon brackets or bumpers with the weight of the boat on the lift. This can cause equipment damage and/or personal injury.
6. The following precautions must be observed when lifting any part of this equipment:
  - a. Be sure of your footing.
  - b. Bend your knees and lift with your legs.
  - c. Hold the equipment section close to your body when lifting.
7. After the pontoon brackets and bumpers are installed, the safety checks in Steps 8 through 25 must be performed on your lift prior to operation. Details on these checks are given in your vertical lift manual.
8. Before allowing anyone to operate the lift, be sure they fully understand the proper operating procedure.

9. Do not operate the lift under the influence of drugs, alcohol, or medication.
10. Keep people and pets clear during operation of the lift.
11. Keep fingers and clothing clear of all moving parts.
12. Never allow people in the boat any time it is suspended above the water on the platform.



**WARNING:**

**DO NOT STAND OR WALK ON THE PLATFORM WHILE IT IS IN ANY RAISED POSITION. THIS CAN CAUSE SERIOUS PERSONAL INJURY.**

13. Do not allow anyone to swim or play under, near or on the lift at any time.
14. Ensure that all bolts and nuts are fastened securely on both this kit and the lift prior to operation.
15. Ensure that the frame is level and square.
16. Completely remove any user or dealer installed locking devices before operating the lift.
17. The boat must be secured on the lift before raising or lowering. Failure to do this can cause equipment damage and/or serious personal injury.
18. Check the lift periodically for frayed cables and/or binding pulleys. If any pulley binds, replace it immediately.
19. Do not try making any adjustments on the lift during operation.
20. Contact your dealer if the winch mechanism fails to perform as described in the Operation chapter of your vertical lift manual.
21. Never tamper with the winch mechanism. This can cause equipment damage.
22. When using a direct drive or motorized friction drive, understand the use of all controls and connections provided with it.



**WARNING:**

**ALL ELECTRIC DRIVES MUST BE INSTALLED AND INSPECTED BY A CERTIFIED ELECTRICIAN IN ACCORDANCE WITH LOCAL ELECTRICAL CODES. THIS INSTALLATION MUST INCLUDE A PROPERLY WORKING GROUND FAULT CIRCUIT INTERRUPTER. (G.F.C.I.)**

23. Never use the lift to hang or store any auxiliary equipment such as boating hardware.
24. The handwheel or power drive must turn clockwise when raising the platform and counter-clockwise when lowering the platform. If the platform operates in the reverse sense, you have reeved the winch incorrectly. You **MUST** follow the winch reeving instructions in your vertical lift manual to prevent equipment damage and/or personal injury. The brake pawl must click during platform raising, indicating that the brake is operative. The self-activating brake mechanism must provide a controlled lowering of the platform.



**WARNING:**

**NEVER RELEASE THE BRAKE PAWL OF THE WINCH. THIS CAN TRIGGER AN UNCONTROLLED SPIN-DOWN OR “FREEWHEEL” OF THE HANDWHEEL. IF FREEWHEELING OCCURS, NEVER TRY TO STOP IT AS THIS CAN CAUSE SERIOUS PERSONAL INJURY.**

25. Padlock the handwheel to the post or lock out your power drive to prevent unauthorized use when your lift is left unattended.

## 2 INSTALLATION AND SET UP

### 2.1 PRE-INSTALLATION CHECKS

1. Do not assemble this kit or any other component of the lift if any part appears to be damaged.
2. Do not weld or other wise modify any portion of the lift. Such alterations may weaken the structural integrity of the lift and void the warranty.
3. This product has been supplied with stainless steel hardware to protect against a harsh marine environment and provide outstanding performance. Due to the chemistry and surface condition of stainless steel, there is a natural tendency for the hardware to “gall, lock up, or seize” during assembly. To prevent this from occurring, it is **highly recommended** that the anti-seize supplied in the hardware bag be applied to the mating surfaces of all stainless steel fasteners before assembly. Lubricants containing molybdenum disulfide, graphite, mica or talc may also be used.



#### **CAUTION:**

**DO NOT EXCEED THE MAXIMUM TORQUE RATING ON ALL BOLTS OF 20 FT-LBS.**



#### **WARNING:**

**FAILURE TO APPLY A SUITABLE LUBRICANT TO THE MATING SURFACES OF STAINLESS STEEL THREADED FASTENERS MAY CAUSE GALLING AND/OR SEIZING OF ASSEMBLY.**

### 2.2 PRIOR TO SETUP

The part reference letters used in the subassembly drawings of sections 2.1 through 2.4 are the same as those shown in Figure 2-1 through Figure 2-4 and listed in the parts lists of Chapter 4.

### 2.3 PONTOON BRACKET ASSEMBLY

1. (Refer to Figure 2-1) Position a Vertical Angle (A), the five larger holes closest to the ground, against the outside face of the Load Tube with the inside angle facing the center of the Load Tube. Insert two 1/2” Hex Head Cap Screws (I), one through the end hole and place below the Load Tube, the second HHCS is then inserted through the Vertical Angle hole closest to the top edge of the Load Tube. Place a Clamp (B), onto the opposite face of the Load Tube and onto both HHCS’s. Next loosely attach a 1/2” flat washer (L), then a 1/2” lock washer (F), and finally a 1/2” hex nut (K). **(DO NOT TIGHTEN AT THIS TIME)**. Making sure the inside of both Vertical Angles face each other on the same Load Tube, repeat step one for the second Pontoon Bracket Vertical Angle.
2. Position a Horizontal Angle (C), between both Vertical Angles. Insert one 3/8 x 1-1/4 HHCS (H), at each end, first through the Horizontal Angle, then through the lowest smaller hole in the Vertical Angle. Next loosely attach a 3/8” flat washer (M), then a 3/8” lock washer (E), and finally a 3/8” hex nut (J). **(DO NOT TIGHTEN AT THIS TIME)**. Repeat step two for the other end of Horizontal Angle.
3. Position a Lower Brace (D), on the inside face of both the Horizontal Angle and Vertical Angle with the flat side facing up. Insert one 3/8 x 1-1/4 HHCS (H), at each end through the Horizontal Angle and Vertical Angle then through Lower Brace, loosely attach a 3/8” flat washer (M), then a 3/8” lock washer (E), and finally a 3/8” hex nut (J). **(DO NOT TIGHTEN AT THIS TIME)**. Repeat step three for second Lower Brace at other end of Horizontal Angle.
4. Center the Pontoon Bracket Assembly left to right on the Load Tube. Then, holding the Vertical Angle 90 degrees to the top edge of the Load Tube, tighten all of the fasteners securely.
5. Repeat steps one through four for the second Pontoon Bracket.

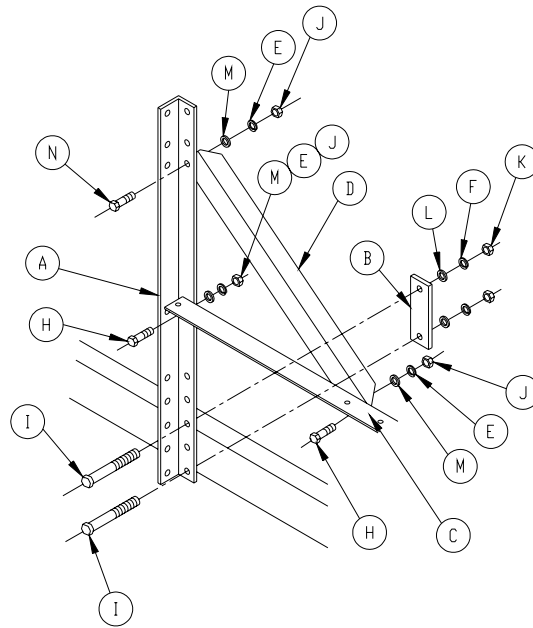

**Figure 2-1.**  
**Pontoon Bracket Installation**

## 2.4 WOOD BUNK INSTALLATION\*\*

\*\* (WOOD BUNKS NOT INCLUDED)

**NOTE:** RGC recommends using 2" x 8" x 16' pressure treated lumber for the bunks.

1. (Refer to Figure 2-2) Center the Bunk\*\* from front to back on the lift and mark the location of the Vertical Angle bunk mounting holes (the two remaining larger holes at the top end of each Vertical Angle). Then drill two 9/16" holes, centered 3" apart at both Vertical Angle marks through the bunk. Counter bore all four holes 1-1/8" diameter approximately 5/16" deep.
2. Position the bunk on the outside face of the Vertical Angle using the two remaining larger holes at the top end of each Vertical Angle. Insert two 1/2" carriage bolts (G), through the counter bored side of bunk, then through the Vertical Angle, next loosely attach a 1/2" flat washer (L), then a 1/2" lock washer (F), and finally a 1/2" hex nut (K), to each carriage bolt. (**DO NOT TIGHTEN AT THIS TIME**). Repeat for other end of bunk, and then tighten fasteners securely.

**MAKE SURE HEAD OF CARRIAGE BOLT IS PULLED BELOW THE SURFACE OF THE WOOD BUNK TO PREVENT HULL MARRING.**

3. Repeat steps one and two for second bunk.

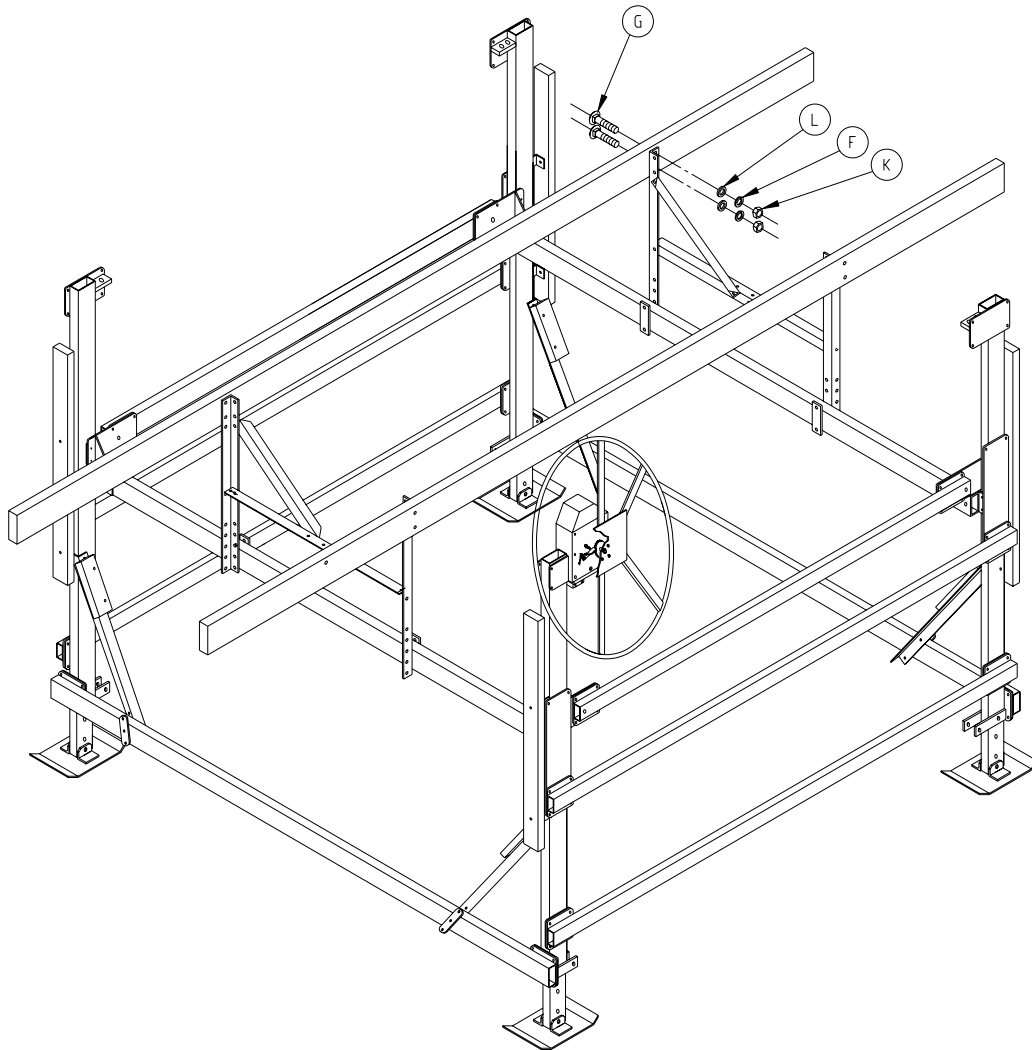

**Figure 2-2.  
Wood Bunk Installation**

## **2.5 CARPETED UPPER BUMPER INSTALLATION.**

1. (Refer to Figure 2-3) Remove one 3/8" x 1-1/4" Hex Head Cap Screw (1), from the bottom end of the Upper Horizontal Support Tube. Insert a 3/8" x 1-1/2" HHCS (P), through the Mounting Angle leg that has mitered corners and reinstall in Support Tube. Using one each 3/8" flat washer (M), lock washer (E), and hex nut (J), fasten Mounting Angle securely.

**NOTE:** The Mounting Angle should be facing the center of the lift, with the Bumper-mounting surface being parallel to the edge of the Horizontal Support Tube Mounting Plate.

2. Position the upper Bumper Mounting Angle using the top hole in the Horizontal Support Tube Mounting Plate (2). Fasten in the same manor as the lower Mounting Angle.
3. Insert a 3/8" carriage bolt (Q), through the counter bored hole that is 6" from the bottom end of the carpeted Upper Bumper. Insert a second carriage bolt through the center counter bored hole in the bumper.
4. Position the carpeted Upper Bumper with the mounting hole 6" from the end closest to the ground and insert upper and lower carriage bolts through the Mounting Angles. Using one each 3/8" flat washer (M), lock washer (E), and hex nut (J), fasten carpeted Upper Bumper (N), to the upper and lower Mounting Angles securely.
5. Repeat this procedure for the other three 48" carpeted Upper Bumpers.

**MAKE SURE HEAD OF CARRIAGE BOLT IS PULLED BELOW THE SURFACE OF THE BUMPER TO PREVENT HULL MARRING.**

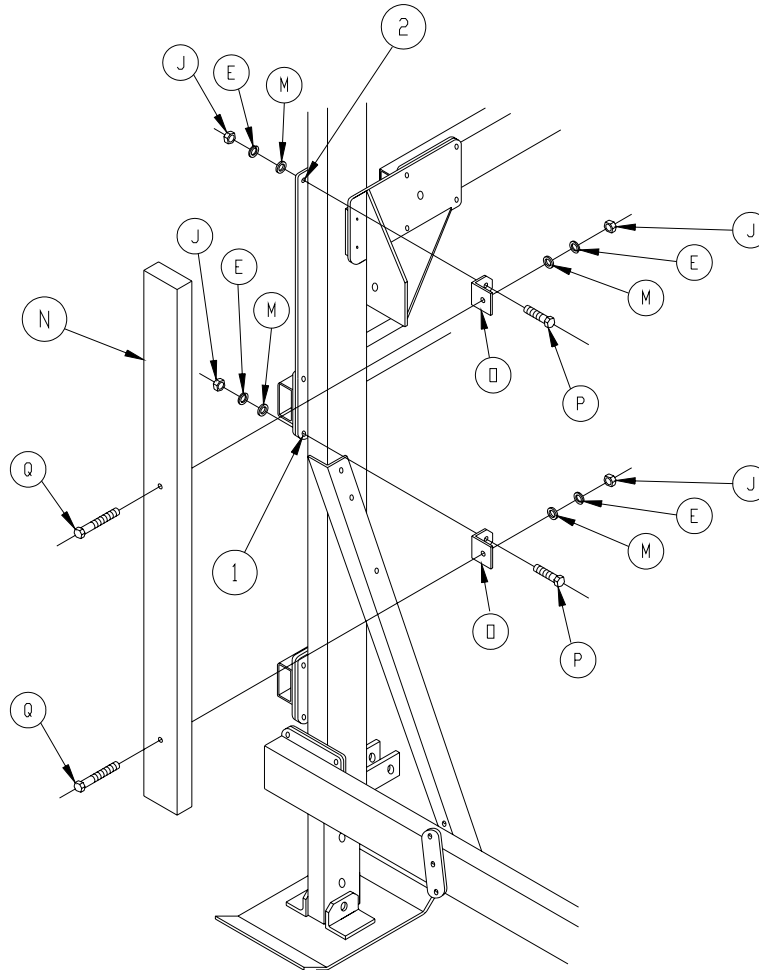
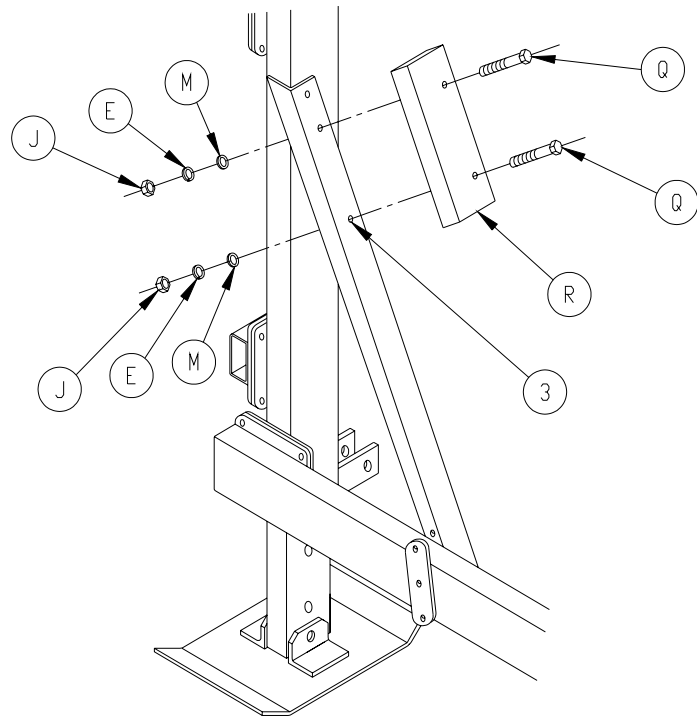

**Figure 2-3.  
Upper Bumper Installation**

**2.6 CARPETED LOWER BUMPER INSTALLATION.**

1. (Refer to Figure 2-4) Insert two 3/8" carriage bolts (Q), through the counter bored holes in the Lower Bumper (R). Using existing holes (3), near the top of the Lower Diagonal Bracket, position Lower Bumper so that it is offset to the outside (front and rear), of the lift to allow for proper clearance of lifting carriage. Using one each 3/8" flat washer (M), lock washer (E), and hex nut (J), to fasten each carriage bolt, secure the carpeted Lower Bumper to the lift.
2. Repeat this procedure for the other three 14" carpeted Lower Bumpers.

**MAKE SURE HEAD OF CARRIAGE BOLT IS PULLED BELOW THE SURFACE OF THE BUMPER TO PREVENT HULL MARRING.**



**Figure 2-4.**  
**Lower Bumper Installation**

## 3 INSPECTION AND MAINTENANCE

### 3.1 GENERAL MAINTENANCE RULES

1. Do not allow persons other than authorized service personnel to repair this equipment.
2. Inspect bumpers and bunks regularly for deterioration. Replace them immediately if they are worn.
3. Do not weld or otherwise modify the lift. Such alterations may weaken the structural integrity of the lift and invalidate your warranty.
4. Completely lower the lift before performing any type of maintenance or repair.



#### **WARNING:**

**NEVER ALLOW ANYBODY TO WORK IN OR ON THE BOAT WHEN IT IS SUSPENDED ABOVE THE WATER ON THE LIFT. IF THE HANDWHEEL ON THE WINCH SHOULD START FREEWHEELING, DEATH OR SERIOUS INJURY COULD RESULT.**

**IF FREEWHEELING STARTS, NEVER TRY TO STOP IT. ALTHOUGH A SPIN DOWN OR “FREEWHEELING” CAN CAUSE LIFT OR BOAT DAMAGE, TRYING TO STOP FREEWHEELING CAN CAUSE SERIOUS PERSONAL INJURY.**

### 3.2 ANNUAL INSPECTION

At least once a year, the lift must be thoroughly inspected using the following procedure.



#### **WARNING:**

**DO NOT ALLOW ANYBODY TO USE THE LIFT UNTIL THIS MAINTENANCE IS COMPLETED.**

1. Tighten all bolts.
2. Check all carpeted wood bumpers and wood bunks for any damage, deterioration, or excessive wear. If any is found, replace them immediately.
3. Check frame thoroughly for defects.

### 3.3 STORAGE PROCEDURE

1. Position boat on platform so the lower unit of the motor is against the optional motor stop (if used).
2. A boat that has water in it from a rain storm could exceed the recommended weight capacity for the lift. Just 1 gallon of water weighs over 8 pounds. Be sure to remove the plug while the boat is up on the lift. Make sure you replace the plug prior to launching your boat.
3. Protect your lift as far as possible from damage caused by environmental factors such as airborne fallout, chemicals, tree sap, and weather hazards.
4. Never use the lift to hang or store any auxiliary equipment such as boating hardware.
5. Do not allow anyone to swim or play near the lift at any time.
6. Padlock the handwheel to the post and disconnect the power to any electric motor when your boat lift is unattended. Never assume you will find the lift in the same condition that you left it.

## 4 PARTS LIST

Each reference number or letter in the following parts lists can be matched with the reference number or letter referred to in the illustrations of the instruction manual.



### **WARNING:**

**FAILURE TO APPLY A SUITABLE LUBRICANT TO THE MATING SURFACES OF STAINLESS STEEL THREADED FASTENERS MAY CAUSE GALLING AND/OR SEIZING OF ASSEMBLY.**

#### **4.1 #3680755 VL PONTOON DECK BRACKET/BUMPER KIT 1.6-4K**

<b>REF #</b>	<b>PART #</b>	<b>QTY</b>	<b>DESCRIPTION</b>
	<b>3658550</b>	<b>1</b>	<b>VL PONTOON DECK/LOWER BUMPER COP – Consisting Of;</b>
A	3603922	4	VL PONTOON DECK BRACKET VERTICAL ANGLE 1.6-4K
B	3603923	4	VL PONTOON DECK BRACKET CLAMP 1.6-4K
C	3603924	2	PONTOON DECK BRACKET HORIZONTAL ANGLE
D	3608037	4	PONTOON LOWER BRACE
	<b>3665555</b>	<b>1</b>	<b>VL PONTOON DECK BRACKET BOB – Consisting Of;</b>
E	5806243	12	3/8 SPLIT LOCKWASHER
F	5806244	16	1/2 SPLIT LOCKWASHER
G	5892501	8	1/2 X 3 CARRIAGE BOLT
H	5896248	12	3/8 X 1-1/4 HEX HEAD CAP SCREW
I	5896290	8	1/2 X 3-1/2 HEX HEAD CAP SCREW
J	5896377	12	3/8 HEX NUT
K	5896379	16	1/2 HEX NUT
L	5896400	16	1/2 SAE FLAT WASHER
M	5896406	12	3/8 SAE FLAT WASHER
	<b>3681755</b>	<b>2</b>	<b>VL UPPER BUMPER KIT (Pair) – Ea. Consisting Of;</b>
N	3608050	2	VL 48” CARPETED UPPER BUMPER
	<b>3656550</b>	<b>1</b>	<b>UPPER BUMPER BOB – Consisting Of;</b>
O	3608051	4	VL VERTICAL LEG BUMPER MOUNTING ANGLE
E	5806243	8	3/8 SPLIT LOCKWASHER
P	5896249	4	3/8 X 1-1/2 HEX HEAD CAP SCREW
Q	5896323	4	3/8 X 2-1/2 CARRIAGE BOLT
J	5896377	8	3/8 HEX NUT
M	5896406	8	3/8 SAE FLAT WASHER
	<b>3603810</b>	<b>2</b>	<b>VL LOWER BUMPER KIT (Pair) – Ea. Consisting Of;</b>
R	3608049	2	VL 14” CARPETED LOWER BUMPER
	<b>3603813</b>	<b>1</b>	<b>VL LOWER BUMPER BOB – Consisting Of;</b>
E	5806243	4	3/8 SPLIT LOCKWASHER
Q	5896323	4	3/8 X 2-1/2 CARRIAGE BOLT
J	5896377	4	3/8 HEX NUT
M	5896406	4	3/8 SAE FLATWASHER

**\*\* Wood Bunks Not Included.** See section 2.4 for requirements.

4.2 #3605945 VL PONTOON DECK BRACKET/BUMPER KIT 4.6-5K

REF #	PART #	QTY	DESCRIPTION
	<b>3658551</b>	<b>1</b>	<b>VL PONTOON DECK/LOWER BUMPER COP – Consisting of;</b>
A	3603920	4	PONTOON DECK BRACKET VERTICAL ANGLE 4.6-5K
B	3603921	4	PONTOON DECK BRACKET CLAMP 4.6-5K
C	3603924	2	PONTOON DECK BRACKET HORIZONTAL ANGLE
D	3608037	4	PONTOON LOWER BRACE
	<b>3665554</b>	<b>1</b>	<b>PONTOON DECK BRACKET BOB – Consisting Of;</b>
E	5806243	12	3/8 SPLIT LOCK WASHER
F	5806244	16	1/2 SPLIT LOCK WASHER
G	5892501	8	1/2 X 3 CARRIAGE BOLT
H	5896248	12	3/8 X 1-1/4 HEX HEAD CAP SCREW
I	5896293	8	1/2 X 4-1/2 HEX HEAD CAP SCREW
J	5896377	12	3/8 HEX NUT
K	5896379	16	1/2 HEX NUT
L	5896400	16	1/2 SAE FLAT WASHER
M	5896406	12	3/8 SAE FLAT WASHER
	<b>3681755</b>	<b>2</b>	<b>VL UPPER BUMPER KIT (Pair) – Ea. Consisting Of;</b>
N	3608050	2	VL 48” CARPETED UPPER BUMPER
	<b>3656550</b>	<b>1</b>	<b>UPPER BUMPER BOB – Consisting Of;</b>
O	3608051	4	VL VERTICAL LEG BUMPER MOUNTING ANGLE
E	5806243	8	3/8 SPLIT LOCK WASHER
P	5896249	4	3/8 X 1-1/2 HEX HEAD CAP SCREW
Q	5896323	4	3/8 X 2-1/2 CARRIAGE BOLT
J	5896377	8	3/8 HEX NUT
M	5896406	8	3/8 SAE FLAT WASHER
	<b>3603810</b>	<b>2</b>	<b>VL LOWER BUMPER KIT (Pair) – Ea. Consisting Of;</b>
R	3608049	2	VL 14” CARPETED LOWER BUMPER
	<b>3603813</b>	<b>1</b>	<b>VL LOWER BUMPER BOB – Consisting Of;</b>
E	5806243	4	3/8 SPLIT LOCK WASHER
Q	5896323	4	3/8 X 2-1/2 CARRIAGE BOLT
J	5896377	4	3/8 HEX NUT
M	5896406	4	3/8 SAE FLAT WASHER

\*\* Wood Bunks Not Included. See section 2.4 for requirements.

## **TWO YEAR LIMITED WARRANTY**

### **Reimann & Georger Corporation Marine Products**

This product is warranted by RGC® Marine Products to the original purchaser to be free from defects in material and workmanship under normal use for a period of two years from the date of purchase.

During the warranty period, and upon proof of purchase, the product will be repaired or replaced (with the same or similar model) at our option, without charge for either parts or labor when serviced at RGC® Marine Products.

Upon completion of repair, the unit will be returned to the customer freight prepaid. The warranty will not apply to this product if it has been misused, abused, or altered.

NEITHER THIS WARRANTY OR ANY OTHER WARRANTY, EXPRESS OR IMPLIED, INCLUDING IMPLIED WARRANTIES OF MERCHANTABILITY, SHALL EXTEND BEYOND THE WARRANTY PERIOD. NO RESPONSIBILITY IS ASSUMED FOR ANY INCIDENTAL OR CONSEQUENTIAL DAMAGES. SOME STATES DO NOT ALLOW EXCLUSION OR LIMITATION OF INCIDENTAL OR CONSEQUENTIAL DAMAGES, SO THE ABOVE LIMITATIONS OR EXCLUSIONS MAY NOT APPLY TO YOU.

This warranty gives you specific legal rights, and you may also have other rights which vary from state to state.