

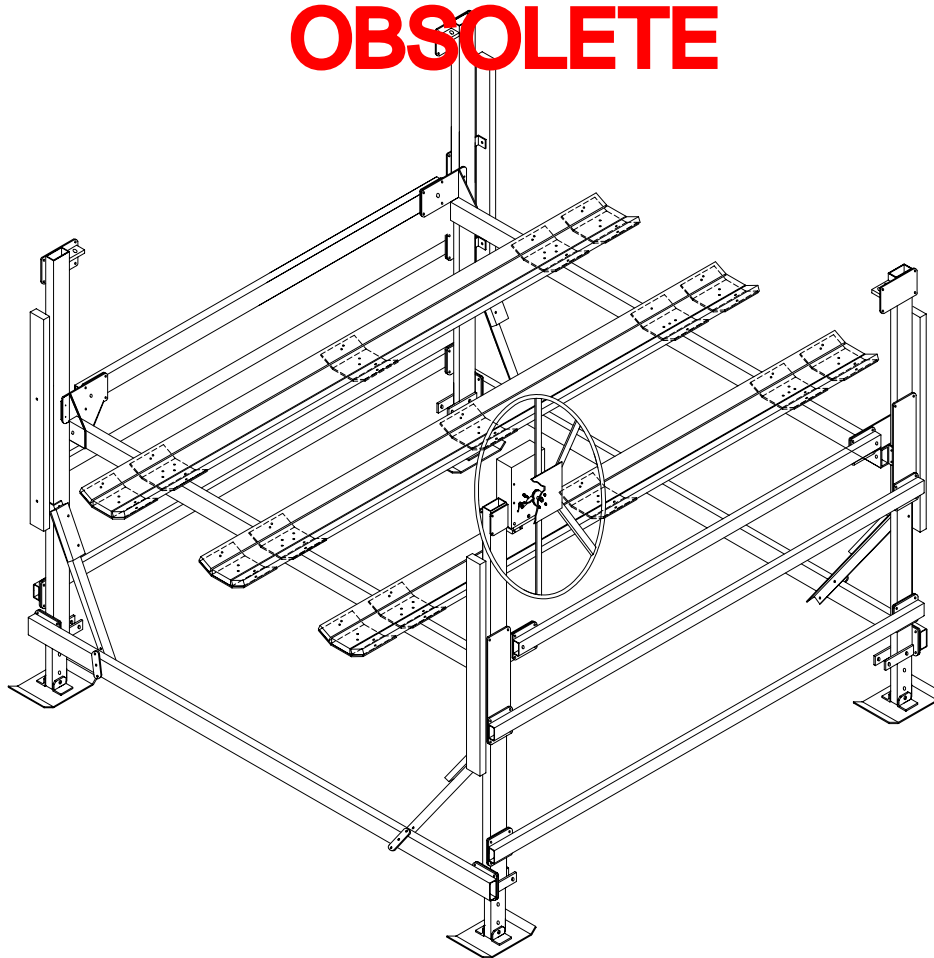

# VL TRITON CRADLE INSTRUCTIONS **OBSOLETE**



REIMANN & GEORGER CORPORATION  
MARINE PRODUCTS  
P/N 6112135

BUFFALO, NY  
07/11/07

## TABLE OF CONTENTS

CHAPTER	TITLE	PAGE
<b>1</b>	<b>SAFETY .....</b>	<b>1</b>
1.1	Introduction .....	1
1.2	Safety Definitions .....	1
1.3	Equipment Safety Labels.....	1
1.4	Safety Rules.....	1
<b>2</b>	<b>INSTALLATION AND SETUP .....</b>	<b>3</b>
2.1	Pre-Installation Checks.....	3
2.2	Tools Required .....	3
2.3	Cradle Positioning .....	4
2.4	Cradle Mounting Plate Assembly .....	5
2.5	Cradle Side Assembly .....	6
2.6	Cradle Support Plate Assembly .....	7
2.7	Lower Carpeted Bumper Assembly.....	8
2.8	Upper Carpeted Bumper Assembly .....	9
<b>3</b>	<b>PARTS LISTS.....</b>	<b>10</b>
3.1	VL1.6-4K Tritoon Cradle and Bumper Kit .....	10
3.2	VL4.6-5K Tritoon Cradle and Bumper Kit .....	10
3.3	VL1.6-4K Tritoon Cradle with Lower Bumper Carton of Parts .....	10
3.4	VL4.6-5K Tritoon Cradle with Lower Bumper Carton of Parts .....	10
3.5	VL Lower Bumper Bag of Bolts .....	11
3.6	VL Upper Bumper Bag of Bolts.....	11

## LIST OF FIGURES

FIGURE	DESCRIPTION .....	PAGE
2-1.	Cradle Positioning .....	4
2-2.	Cradle Mounting Plate Assembly .....	5
2-3.	Cradle Side Assembly .....	6
2-4.	Cradle Support Plate Assembly .....	7
2-5.	Lower Carpeted Bumper Assembly.....	8
2-6.	Upper Carpeted Bumper Assembly .....	9

# 1 SAFETY

## 1.1 INTRODUCTION

Your Reimann & Georger Corporation Marine Products VL Tritoon Cradle Kit is designed to lift boat by pontoons rather than deck and aid in proper positioning of boat on the lift. Your Tritoon Cradle Kit is well designed and well built. However, like any other equipment, it can malfunction or become hazardous in the hands of an inexperienced and/or untrained user. Therefore, read this manual and your related Vertical Lift manual, and related equipment manuals thoroughly before installing this kit and operating your lift to provide maximum safety for all operating personnel, and to get the maximum benefit from your equipment.

## 1.2 SAFETY DEFINITIONS

A safety message alerts you to potential hazards that could hurt you or others or cause property damage. The safety messages or signal words for product safety signs are **DANGER**, **WARNING**, and **CAUTION**. Each safety message is preceded by a safety alert symbol and is defined as follows:

**DANGER:** Indicates an imminently hazardous situation which, if not avoided, **will** cause death or serious injury. This safety message is limited to the most extreme situations.

**WARNING:** Indicates a potentially hazardous situation which, if not avoided, **could** result in death or serious injury.

**CAUTION:** Indicates a potentially hazardous situation which, if not avoided, **may** result in minor or moderate injury. It may also be used to alert against unsafe practices and property-damage-only accidents.

## 1.3 EQUIPMENT SAFETY LABELS

These labels warn you of potential hazards that could cause injury. Read them carefully. If a label comes off or becomes illegible, contact a Reimann & Georger Corporation dealer for a replacement.

## 1.4 SAFETY RULES



### **WARNING:**

**DO NOT INSTALL THIS KIT AND OPERATE THE LIFT WITHOUT READING BOTH THIS MANUAL AND YOUR VERTICAL LIFT MANUAL. FAILURE TO DO THIS CAN LEAD TO EQUIPMENT MISUSE WITH RESULTING DAMAGE AND/OR SERIOUS PERSONAL INJURY. CONTACT YOUR RGC® MARINE DEALER IF YOU HAVE ANY QUESTIONS.**

1. Do not install this kit without first replacing any damaged or defective parts.
2. The Tritoon kit does not increase the rated capacity of the lift. Never use the lift beyond its rated capacity. This can damage the kit assembly, lift, and/or boat with resulting serious personal injury.
3. Never try using any part of this kit in an application for which it was not designed.
4. Do not weld or otherwise modify any part of this kit. Such alterations may weaken the structural integrity of the lift and void the warranty.
5. Do not try installing the pontoon brackets or bumpers with the weight of the boat on the lift. This can cause equipment damage and/or personal injury.
6. The following precautions must be observed when lifting any part of this equipment:
  - a. Be sure of your footing.
  - b. Bend your knees and lift with your legs.
  - c. Hold the equipment section close to your body when lifting.
7. After the Tritoon kit is installed, the safety checks in Steps 8 through 25 must be performed on your lift prior to operation. Details on these checks are given in your vertical lift manual.

8. Before allowing anyone to operate the lift, be sure they fully understand the proper operating procedure.
9. Do not operate the lift under the influence of drugs, alcohol, or medication.
10. Keep people and pets clear during operation of the lift.
11. Keep fingers and clothing clear of all moving parts.
12. Never allow people in the boat any time it is suspended above the water on the platform.



**WARNING:**

**DO NOT STAND OR WALK ON THE PLATFORM WHILE IT IS IN ANY RAISED POSITION. THIS CAN CAUSE SERIOUS PERSONAL INJURY.**

13. Do not allow anyone to swim or play under, near or on the lift at any time.
14. Ensure that all bolts and nuts are fastened securely on both this kit and the lift prior to operation.
15. Ensure that the frame is level and square.
16. Completely remove any user or dealer installed locking devices before operating the lift.
17. The boat must be secured on the lift before raising or lowering. Failure to do this can cause equipment damage and/or serious personal injury.
18. Check the lift periodically for frayed cables and/or binding pulleys. If any pulley binds, replace it immediately.
19. Do not try making any adjustments on the lift during operation.
20. Contact your dealer if the winch mechanism fails to perform as described in the Operation chapter of your vertical lift manual.
21. Never tamper with the winch mechanism. This can cause equipment damage.
22. When using a direct drive or motorized friction drive, understand the use of all controls and connections provided with it.



**WARNING:**

**ALL ELECTRIC DRIVES MUST BE INSTALLED AND INSPECTED BY A CERTIFIED ELECTRICIAN IN ACCORDANCE WITH LOCAL ELECTRICAL CODES. THIS INSTALLATION MUST INCLUDE A PROPERLY WORKING GROUND FAULT CIRCUIT INTERRUPTER. (G.F.C.I.)**

23. Never use the lift to hang or store any auxiliary equipment such as boating hardware.
24. The handwheel or power drive must turn clockwise when raising the platform and counter-clockwise when lowering the platform. If the platform operates in the reverse sense, you have reeved the winch incorrectly. You **MUST** follow the winch reeving instructions in your vertical lift manual to prevent equipment damage and/or personal injury. The brake pawl must click during platform raising, indicating that the brake is operative. The self-activating brake mechanism must provide a controlled lowering of the platform.



**WARNING:**

**NEVER RELEASE THE BRAKE PAWL OF THE WINCH. THIS CAN TRIGGER AN UNCONTROLLED SPIN-DOWN OR “FREEWHEEL” OF THE HANDWHEEL. IF FREEWHEELING OCCURS, NEVER TRY TO STOP IT AS THIS CAN CAUSE SERIOUS PERSONAL INJURY.**

25. Padlock the handwheel to the post or lock out your power drive to prevent unauthorized use when your lift is left unattended.

## 2 INSTALLATION AND SET UP

### 2.1 PRE-INSTALLATION CHECKS

1. Do not assemble this kit or any other component of the lift if any part appears to be damaged.
2. Do not weld or other wise modify any portion of the lift. Such alterations may weaken the structural integrity of the lift and void the warranty.
3. This product has been supplied with stainless steel hardware to protect against a harsh marine environment and provide outstanding performance. Due to the chemistry and surface condition of stainless steel, there is a natural tendency for the hardware to “gall, lock up, or seize” during assembly. To prevent this from occurring, it is **highly recommended** that the anti-seize supplied in the hardware bag be applied to the mating surfaces of all stainless steel fasteners before assembly. Lubricants containing molybdenum disulfide, graphite, mica or talc may also be used.



#### **CAUTION:**

**DO NOT EXCEED THE MAXIMUM TORQUE RATING ON ALL BOLTS OF 20 FT-LBS.**



#### **WARNING:**

**FAILURE TO APPLY A SUITABLE LUBRICANT TO THE MATING SURFACES OF STAINLESS STEEL THREADED FASTENERS MAY CAUSE GALLING AND/OR SEIZING OF ASSEMBLY.**

### 2.2 TOOLS REQUIRED

1. 9/16” Wrench or Adjustable Wrench.
2. Drill Motor.
3. 7/16” drill bit.
4. 1” flat wood bit for counter sinking holes.

**Please NOTE;** If additional cushioning is desired carpet can be wrapped around the wood.



#### **CAUTION:**

**AT A MINIMUM, THIS KIT SHOULD BE INSTALLED USING THIN CARPET, RUBBER, OR CORK SHEETING AS A BARRIER BETWEEN PRESSURE TREATED WOOD AND ALUMINUM MOUNTING BRACKETS. FAILURE TO INSTALL A BARRIER COULD SHORTEN THE LIFE EXPECTANCY OF THIS KIT OR PONTOON MATERIAL. CONTACT YOUR RGC® MARINE DEALER IF YOU HAVE ANY QUESTIONS.**

### 2.3 CRADLE POSITIONING

1. Refer to **Figure 2-1**. Position the four-hole cradle mounting plates (1) face-up and centered on the load tubes. Measure the beam of your pontoon boat when locating the plates. Boat should remain centered on lift for best operation.
2. Place one 2" x 6" x 12' pressure treated wood (customer supplied) on top of each pair of cradle mounting plates, spanning from one load tube to the other. Center the wood so that there is an equal amount protruding at each end.

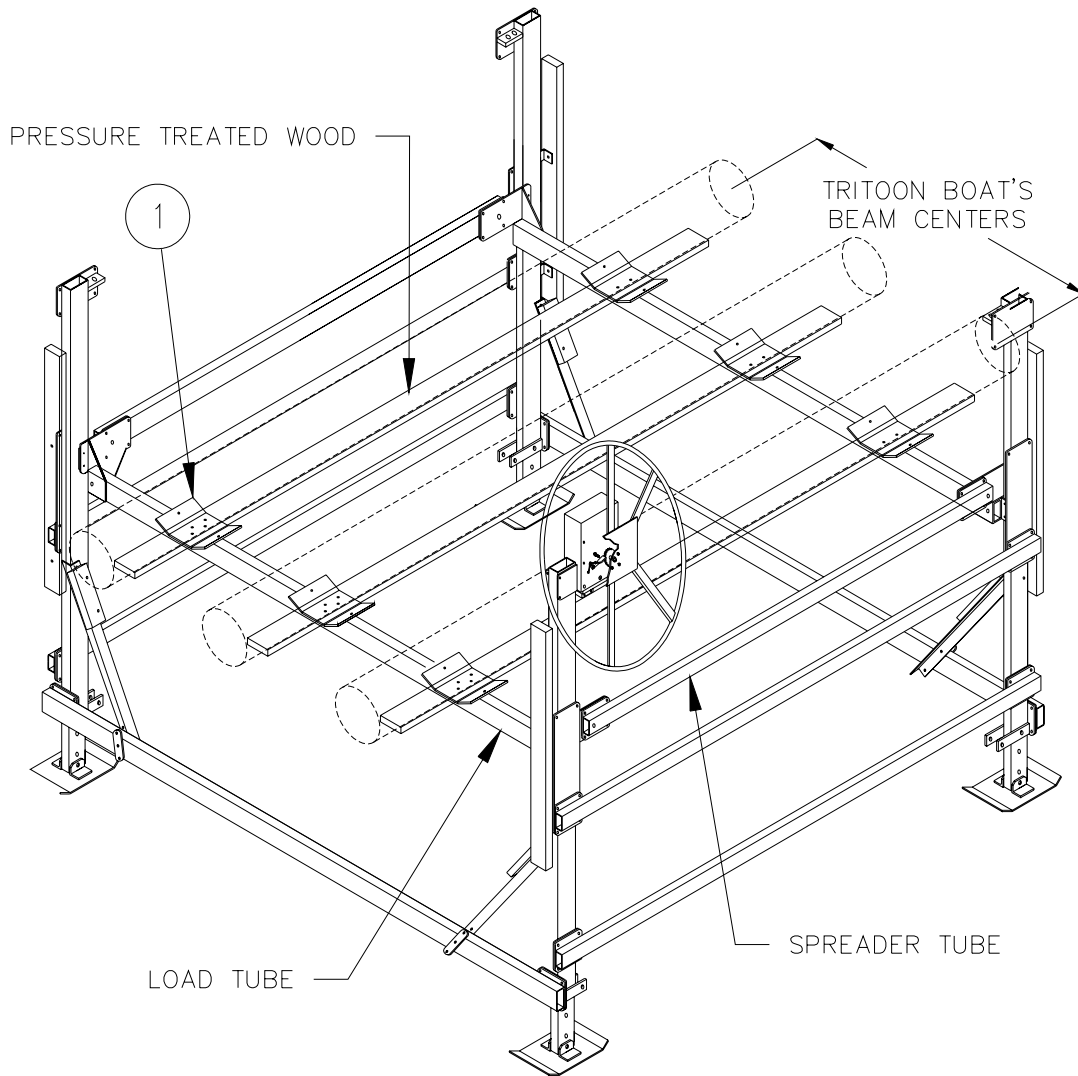

**Figure 2-1.**  
**Cradle Positioning**

## 2.4 CRADLE MOUNTING PLATE ASSEMBLY

1. **Refer to Figure 2-2.** Using the six cradle mounting plates (1) as templates, mark both hole locations of each center section on wood and drill corresponding holes using the 7/16" drill bit. As an option you may wish to countersink the holes so the head of the carriage bolt (C) lies below the surface of the wood. In this instance, countersink 1/4" deep using 1" flat wood bit.
2. Place a barrier material between pressure treated wood and aluminum mounting plates as noted in Section 2.2 above.
  - If you choose to cover the wood entirely with carpeting, fold a few inches under the 2" x 6" wood with the seam kept on the bottom of wood. Attach carpet to wood with staples.
3. Attach each cradle mounting plate onto the load tube by aligning a 2-Hole Plate (A) underneath the tube and fastening with two carriage bolts (C), two flat washers (F), two split-lock washers (B), and two hex nuts (H).

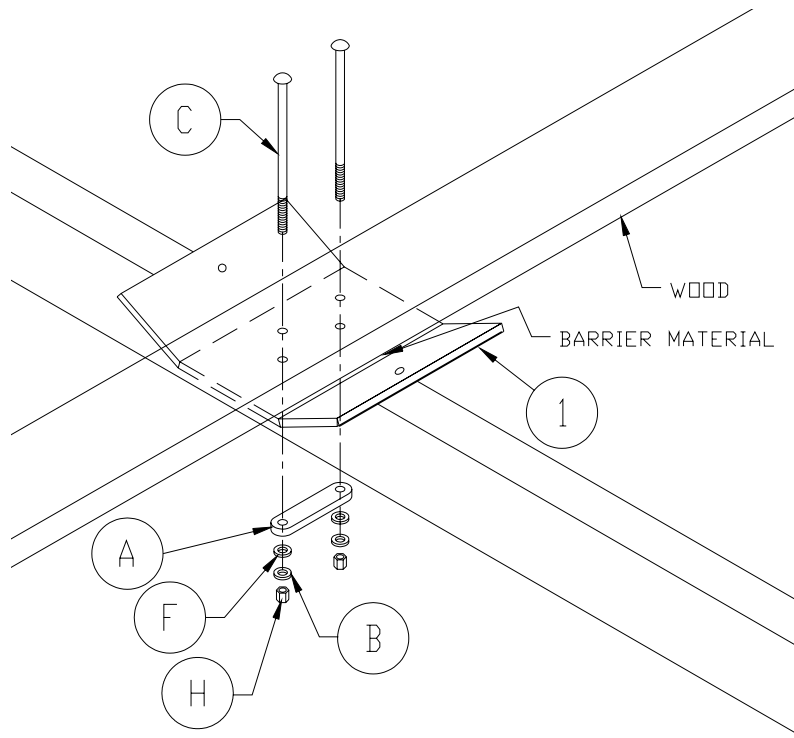

**Figure 2-2.**  
**Cradle Mounting Plate Assembly**

## 2.5 CRADLE SIDE ASSEMBLY

1. **Refer to Figure 2-3.** Place two of the 2" x 4" x 12' pressure treated wood into each pair of Mounting Plates, one on each side of the 2" x 6". Ensure that the ends of the wood are even with one another.
2. Once again use the six mounting plates as templates and locate the remaining holes onto the wood. Drill holes using the 7/16" drill bit, and again, use a 1" flat wood bit to do the optional countersink of 1/4" deep.

Place a barrier material between pressure treated wood and aluminum mounting plates as noted in Section 2.2 above.

- If you choose to cover the wood entirely with carpeting, fold a few inches under the 2" x 4" wood with the seam kept on the bottom of wood. Attach carpet to wood with staples.
3. Bolt the 2" x 4" wood onto each cradle mounting plate using: two carriage bolts (D), two flat washers (F), two split-lock washers (B), and two hex nuts (E).
  - Having the wood bolted in place on the cradle mounting plates shall make it easier to mount the support plates (2) in the following step.

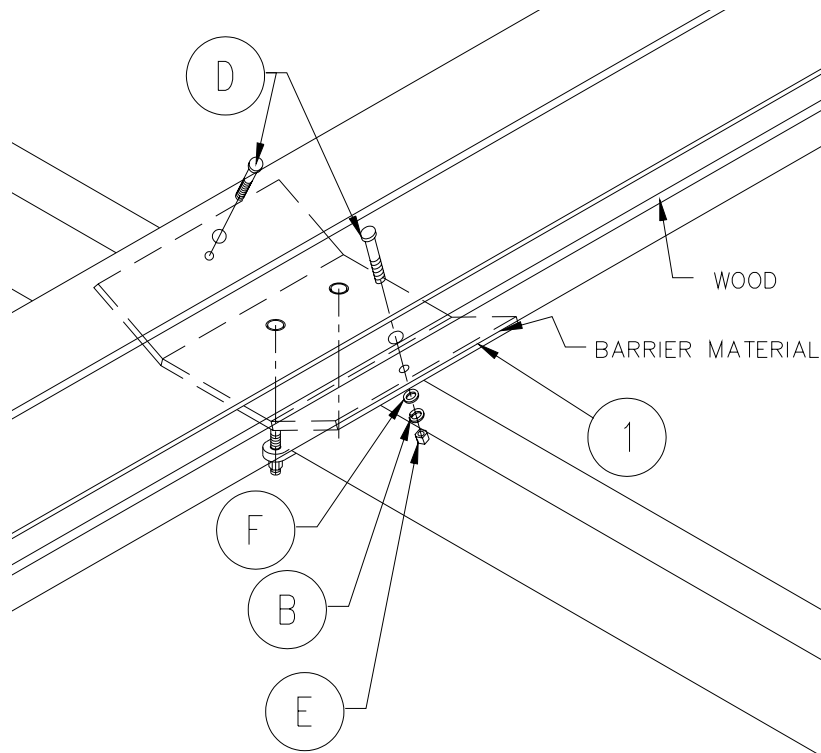

**Figure 2-3.**  
**Cradle Side Assembly**

## 2.6 CRADLE SUPPORT PLATE ASSEMBLY

1. Refer to **Figure 2-4**. Position the nine three-hole cradle support plates (2) onto the underside of the wood, three on each pontoon cradle. One each end and one at approximately center.
2. Mark the location of the three holes for each support plate (2) and drill the necessary holes using the 7/16" drill bit. Next drill the optional 1/4" deep countersink.
3. Attach each support plate (2) to the underside of the three pieces of wood using: three carriage bolts (D), three flat washers (F), three split-lock washers (B), and three hex nuts (E).

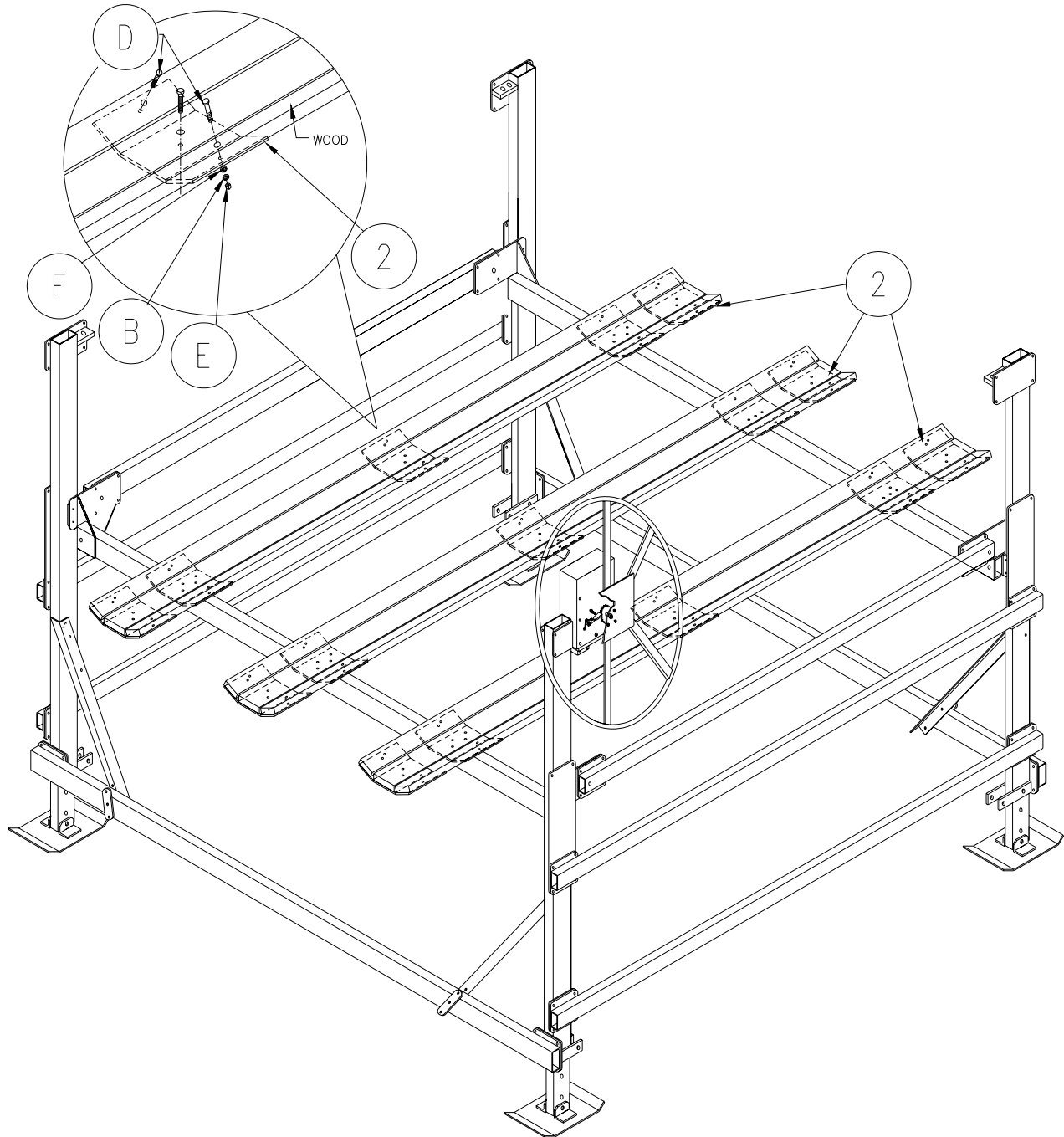
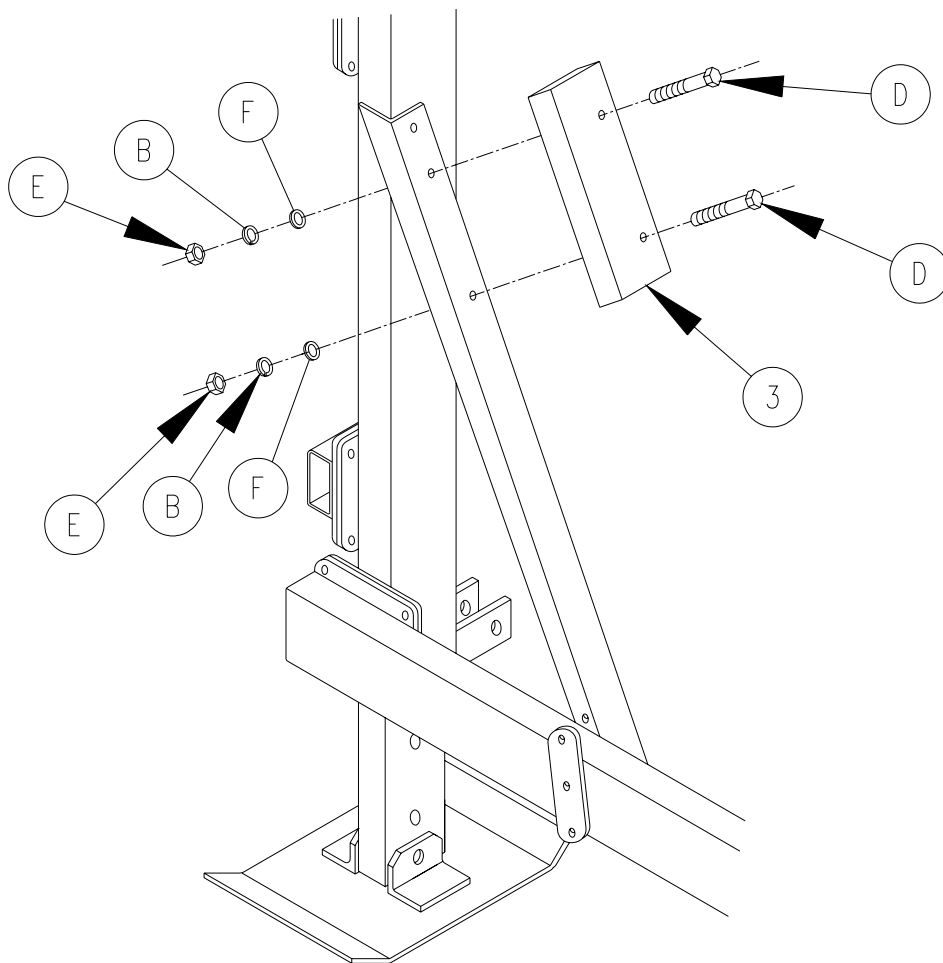

**Figure 2-4.**  
**Cradle Support Plate Assembly**

## 2.7 LOWER CARPETED WOOD BUMPER ASSEMBLY

1. Refer to Figure 2-5. Insert two carriage bolts (D), through the counter bored holes in the lower bumper (3). Using existing holes, near the top of the lower diagonal bracket, position lower bumper (3), so that it is offset to the outside (front and rear), of the lift to allow for proper clearance of lifting carriage. Use two each: flat washer (F), lock washer (B), and hex nut (E), to fasten carpeted lower bumper to the lift.
2. Repeat this procedure for the other three carpeted lower bumpers.

**Please NOTE; Make sure head of carriage bolt is pulled below the surface of the Bumper to prevent pontoon marring.**



**Figure 2-5.**  
**Lower Carpeted Wood Bumper**

## 2.8 UPPER CARPETED WOOD BUMPER ASSEMBLY

1. Refer to Figure 2-6. Remove one 3/8" x 1-1/4" Hex Head Cap Screw (P), from the bottom end of the upper horizontal support tube. Insert a hex head cap screw (G), through the mounting angle leg (5), that has mitered corners and reinstall in support tube. Using one each: flat washer (F), split-lock washer (B), and hex nut (E), fasten mounting angle securely.

**NOTE:** The mounting angle should be facing the center of the lift, with the bumper-mounting surface being parallel to the end of boat lift.

2. Position the upper mounting angle using the top hole (6) in the horizontal support tube mounting plate. Fasten in the same manor as the lower mounting angle.
3. Insert carriage bolt (D), through the counter bored hole that is 6" from the bottom end of the vertical leg carpeted bumper (4). Insert a second carriage bolt through the center counter bored hole in the bumper.
4. Position the vertical leg carpeted bumper with the mounting hole 6" from the end closest to the ground and insert upper and lower carriage bolts through the mounting angles. Using one each; flat washer (F), lock washer (B), and hex nut (E), fasten vertical leg carpeted upper bumper to the upper and lower mounting angles securely.
5. Repeat this procedure for the other three 48" vertical leg carpeted upper bumpers.

**Please NOTE; Make sure head of carriage bolt is pulled below the surface of the bumper to prevent hull marring.**

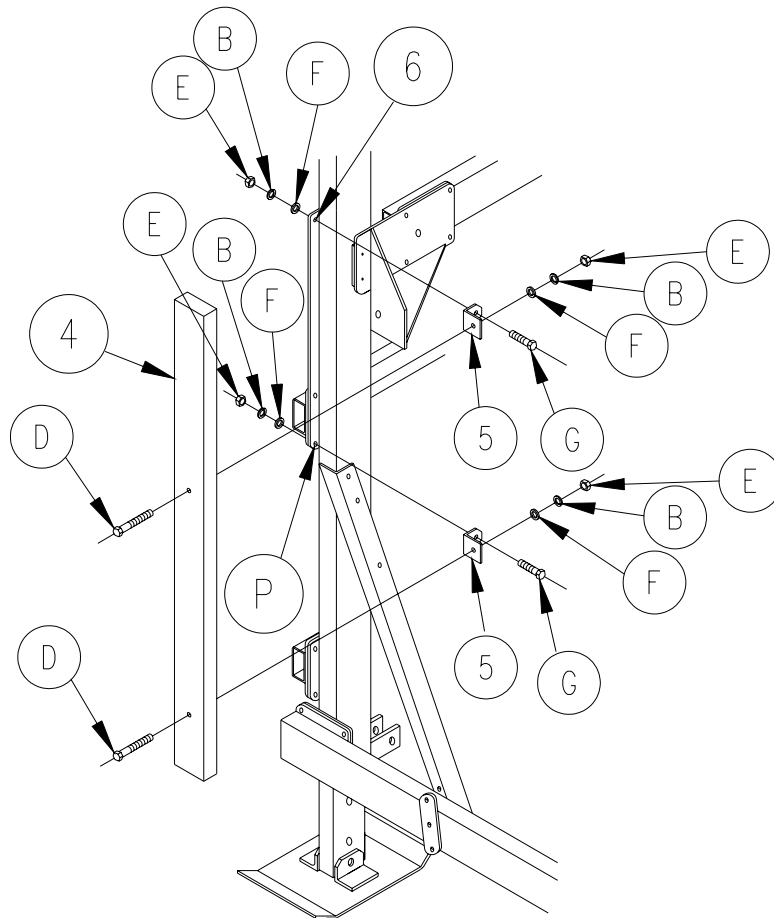

Figure 2-6.

### Upper Carpeted Wood Bumper Assembly

### 3 PARTS LISTS

Each reference number or letter in the following parts lists can be matched with the reference number or letter referred to in both the text and illustrations of Chapter 3, Installation and Setup.



#### **WARNING:**

**FAILURE TO APPLY A SUITABLE LUBRICANT TO THE MATING SURFACES OF STAINLESS STEEL THREADED FASTENERS MAY CAUSE GALLING AND/OR SEIZING OF ASSEMBLY.**

#### 3.1 VL TRITOON CRADLE AND BUMPER KIT 1.6-4K

Reference	Part Number	Quantity	Description
	3678954	1	VL TRITOON CRADLE/ LWR BUMPER 1.6-4K Carton of parts (see Section 3.3)
	3681755	2	VL UPPER BUMPER KIT (PAIR) (see Section 3.6)

#### 3.2 VL TRITOON CRADLE AND BUMPER KIT 4.6-5K

Reference	Part Number	Quantity	Description
	3678953	1	VL TRITOON CRADLE/ LWR BUMPER 4.6-5K Carton of parts (see Section 3.4)
	3681755	2	VL UPPER BUMPER KIT (PAIR) (see Section 3.6)

#### 3.3 VL TRITOON CRADLE WITH LOWER BUMPER 1.6-4K CARTON OF PARTS

Reference	Part Number	Quantity	Description
1	3603391	6	PONTOON CRADLE MOUNTING PLATE 1.6-4K
2	3603390	9	PONTOON CRADLE SUPPORT PLATE 1.6-4K
3	3608049	4	LOWER WOOD BUMPER 14"
	3603813	2	VL LOWER BUMPER BAG OF BOLTS (see Section 3.5)
	<b>3603397</b>	<b>1</b>	<b>VL TRITOON CRADLE BAG OF BOLTS 1.6-4K</b>
			<i>Consisting of:</i>
A	3603835	6	2-HOLE PLATE 2"
B	5806243	51	3/8 SPLIT-LOCK WASHER
C	5893601	12	3/8 x 8 CARRIAGE BOLT
D	5896323	39	3/8 x 2-1/2 CARRIAGE BOLT
E	5896377	39	3/8 HEX NUT
F	5896406	51	3/8 SAE FLAT WASHER
H	5803638	12	3/8 HEX NUT –SILICON BRONZE

#### 3.4 VL TRITOON CRADLE WITH LOWER BUMPER 4.6-5K CARTON OF PARTS

Reference	Part Number	Quantity	Description
1	3603388	6	PONTOON CRADLE MOUNTING PLATE 5K
2	3603389	9	PONTOON CRADLE SUPPORT PLATE 5K
3	3608049	4	LOWER WOOD BUMPER 14"
	3603813	2	VL LOWER BUMPER BAG OF BOLTS (see Section 3.5)
	<b>3603398</b>	<b>1</b>	<b>TRITOON CRADLE BAG OF BOLTS 4.6-5K</b>
			<i>Consisting of:</i>
A	3606921	6	2-HOLE PLATE 3"
B	5806243	51	3/8 SPLIT-LOCK WASHER
C	5893601	12	3/8 x 8 CARRIAGE BOLT
D	5896323	39	3/8 x 2-1/2 CARRIAGE BOLT
E	5896377	39	3/8 HEX NUT
F	5896406	51	3/8 SAE FLAT WASHER
H	5803638	12	3/8 HEX NUT –SILICON BRONZE

### 3.5 VL LOWER BUMPER BAG OF BOLTS

Reference	Part Number	Quantity	Description
B	5806243	4	3/8 SPLIT-LOCK WASHER
D	5896323	4	3/8 x 2-1/2 CARRIAGE BOLT
E	5896377	4	3/8 HEX NUT
F	5896406	4	3/8 SAE FLAT WASHER

### 3.6 VL UPPER BUMPER KIT

Reference	Part Number	Quantity	Description
4	3608050	2	VL UPPER BUMPER CARPETED 4'
	<b>3656550</b>	<b>1</b>	<b>VL UPPER BUMPER BAG OF BOLTS</b>
			<i>Consisting of:</i>
B	5806243	8	3/8 SPLIT-LOCK WASHER
D	5896323	4	3/8 x 2-1/2 CARRIAGE BOLT
E	5896377	8	3/8 HEX NUT
F	5896406	8	3/8 SAE FLAT WASHER
G	5896249	4	3/8 x 1-1/2 HEX HEAD CAP SCREW
5	3608051	4	VERTICAL LEG BUMPER MOUNTING ANGLE

#### RECOMMENDED WOOD (NOT INCLUDED)

- 3 PCS 2" x 6" x 12' PRESSURE TREATED WOOD
- 6 PCS 2" x 4" x 12' PRESSURE TREATED WOOD

## **TWO YEAR LIMITED WARRANTY**

### **Reimann & Georger Corporation Marine Products**

This product is warranted by RGC® Marine Products to the original purchaser to be free from defects in material and workmanship under normal use for a period of two years from the date of purchase.

During the warranty period, and upon proof of purchase, the product will be repaired or replaced (with the same or similar model) at our option, without charge for either parts or labor when serviced at RGC® Marine Products.

Upon completion of repair, the unit will be returned to the customer freight prepaid. The warranty will not apply to this product if it has been misused, abused, or altered.

NEITHER THIS WARRANTY OR ANY OTHER WARRANTY, EXPRESS OR IMPLIED, INCLUDING IMPLIED WARRANTIES OF MERCHANTABILITY, SHALL EXTEND BEYOND THE WARRANTY PERIOD. NO RESPONSIBILITY IS ASSUMED FOR ANY INCIDENTAL OR CONSEQUENTIAL DAMAGES. SOME STATES DO NOT ALLOW EXCLUSION OR LIMITATION OF INCIDENTAL OR CONSEQUENTIAL DAMAGES, SO THE ABOVE LIMITATIONS OR EXCLUSIONS MAY NOT APPLY TO YOU.

This warranty gives you specific legal rights, and you may also have other rights which vary from state to state.