

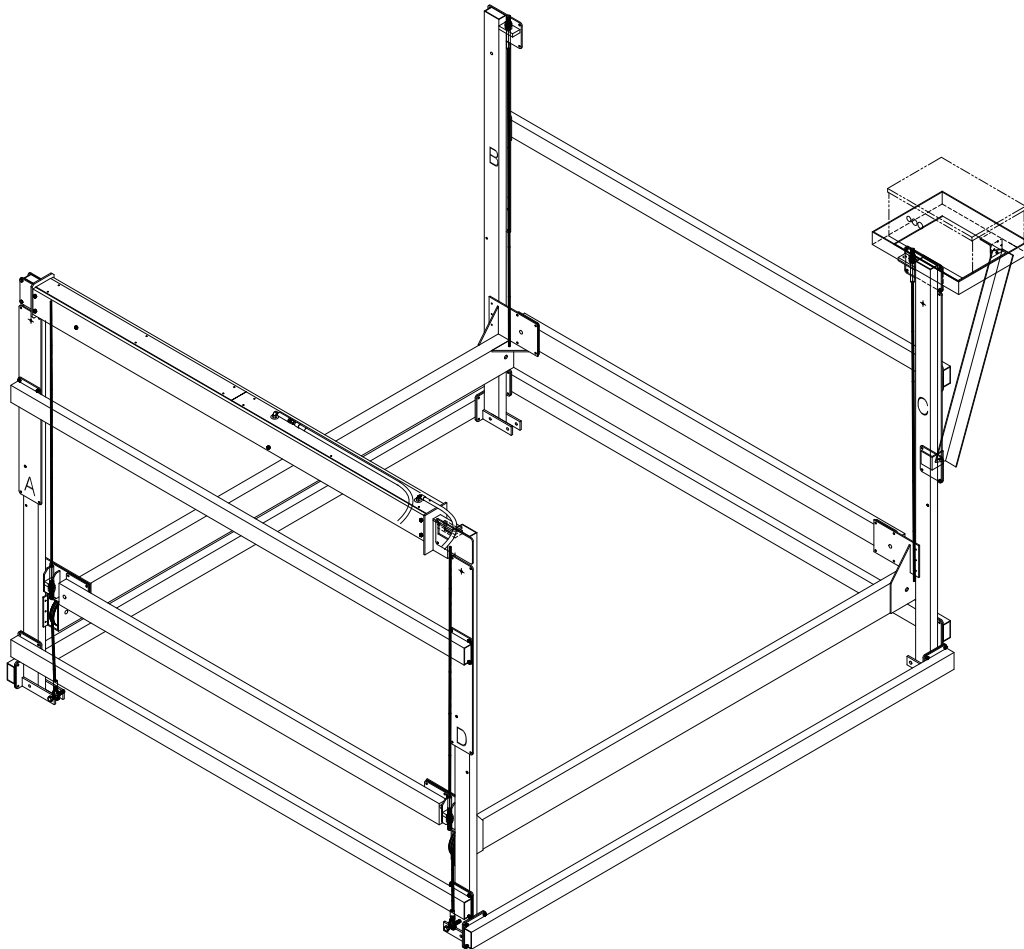

HVL7K TALL HYD. VERTICAL LIFT CONVERSION KIT INSTRUCTIONS



REIMANN & GEORGER CORPORATION
MARINE PRODUCTS
P/N 611----

BUFFALO, NY
4/22/08

PRE-LIFTING CHECKLIST

The lift and related equipment must be thoroughly inspected prior to each use. Only those who have read and understood this entire manual and related equipment manuals are qualified to do this inspection. This checklist is to be used as a guideline in conjunction with the maintenance and inspection procedures outlined in this manual. It is recommended that the inspection be maintained as a permanent record.

- Insure the lift installation will clear all power lines and obstructions.
- Insure all structural members of the lift are free of defects and damage that may affect the integrity.
- Insure that an electric drive, if used, has been inspected and installed by a certified electrician in accordance with local electrical codes. A Ground Fault Circuit Interrupter (G.F.C.I.) must be installed by your electrician and work properly.
- Insure that any user or dealer installed locking devices have been removed before operating the lift.
- Operate the lift first without, and then with, your boat on the platform to test the operation of both the lift and the winch.
- Insure the boat is properly positioned on the lift before doing any raising or lowering.
- Insure the lift is not being used beyond its rated capacity.
- Insure any drain plug is in place on the boat before launching.
- Conduct the wire rope inspection procedure described in Chapter 5 at least monthly.
- Insure the leg pins connect the vertical legs to the adjustable legs. Insure the leg height has been properly adjusted according to the water depth.
- Insure the frame and platform fastenings are tight.
- Insure the lower diagonal braces are installed in each corner.
- Insure the frame is level and square according to the dimensions shown in Figure 3-6, Chapter 3.
- Insure the cable end loops of the load and spreader tubes are fastened to the bracket at the bottom of each vertical leg.
- Insure the cable studs opposite the cable end loops in the platform assembly are tight. If tightening is needed, follow the sequence described in Section 3.8 of Chapter 3. Then tighten the jam nuts to the cable nuts to lock the position.
- Insure the winch is securely fastened to vertical leg "A".
- Insure the handwheel has been attached to the winch hubplate.
- Insure the spinner knob is attached to the handwheel using the preassembled hardware.
- Insure the A-B load tube cable is properly reeved and fastened for correct winch operation.
- Insure set screw securing wire rope end to the drum is tight and in good condition.
- When facing the front of the handwheel, the wire rope must wind and unwind from the left side of the winch. This reeving raises the platform when turning the handwheel clockwise and lowers the platform when turning the handwheel counterclockwise. The brake pawl must click, meaning the brake is operative.
- Insure the guards are in place before operating the winch.
- Insure the plastic caps are installed onto the tops of the vertical legs and the ends of the upper short horizontal tubes.

TABLE OF CONTENTS

CHAPTER	TITLE	PAGE
1	SAFETY	1
1.1	Introduction	1
1.2	Safety Definitions	1
1.3	Equipment Safety Labels.....	1
1.4	Equipment And Personnel Safety	1
1.5	Installation Safety	2
1.6	Operating Safety.....	2
1.6.1	General	2
1.6.2	Safety When Raising the Boat.....	3
1.6.3	Safety When Lowering the Boat	3
1.7	Maintenance and Storage Safety	3
2	SPECIFICATIONS	5
2.1	Technical Data.....	5
2.2	Nameplate and Serial Number Tag.....	5
2.3	Optional Equipment.....	5
3	INSTALLATION AND SETUP	7
3.1	Pre-Installation Checks.....	7
3.2	Prior To Setup	7
3.3	Platform Disassembly.....	8
3.4	A-B & C-D Load Tube Assembly	9
3.5	‘B’ Leg Conversion	10
3.6	Platform Assembly	10
3.7	Mounting The Platform To The Frame	11
3.8	Mounting The Lower Diagonal Braces	12
3.9	Platform Reeving And Adjustment	13
3.10	Hydraulic Lift Assembly Mounting.....	14
3.11	VL Hydraulic Shelf Frame (Optional).....	14
3.12	Reeving The Hydraulic Cylinder.....	16
3.13	Hydraulic Hose Routing	17
3.14	Moving Lift To Operating Position	18
4	OPERATION.....	19
4.1	Before Operating The Lift	19
4.2	Testing Hydraulic Lift Operation	19
4.3	Testing Hydraulic Lift Operation With Remotes	19
4.4	Raising And Lowering The Platform	20
4.5	Securing Lift When Not In Use.....	20
5	INSPECTION AND MAINTENANCE	22
5.1	General Maintenance Rules.....	22
5.2	Wire Rope Inspection Procedure.....	23
5.3	Annual Inspection.....	23
5.4	Battery Maintenance.....	23
5.5	Remote Control Information	24
5.6	Storage Procedure.....	25
5.7	Hydraulic System Flush.....	25
6	TROUBLESHOOTING.....	27

TABLE OF CONTENTS (CONTINUED)

CHAPTER	TITLE	PAGE
7	PARTS LISTS.....	32
7.1	HVL 50124 Conversion Kit Bundle.....	32
7.1.1	HVL 50124 Bundle 1 of 1	32
7.2	HVL 50124Tall Conversion Kit Bundle	32
7.2.1	HVL 50124T Bundle 1 of 1	32
7.3	HVL Conversion Kit Hardware Carton 5K.....	33
7.4	3641340 HVL Power Unit	34
7.5	3641220 HVL Power Unit Shelf & Hardware	34
7.6	3641345 HVL 5K Hydraulic Lift Cylinder Assembly	34
7.7	3641380 HVL 5K Tall Hydraulic Lift Cylinder Assembly	35

LIST OF FIGURES

FIGURE	DESCRIPTION	PAGE
2-1	Typical Product Nameplate	5
3-1	Vertical Lift Frame & Platform Assembly	7
3-2	Lift/Dock Placement Options	8
3-3	Platform Assembly	9
3-4	C-B Frame Side Assembly	10
3-5	Platform Assembly—Isometric View.....	11
3-6	Frame Squaring Assembly/Table	12
3-7	Lower Diagonal Brace Assembly.....	13
3-8	Cable Reeving & Adjustment.....	14
3-9	VL Hydraulic Cylinder Mounting	15
3-10	VL Hydraulic Power Unit Shelf Mounting	15
3-11	Hydraulic Cylinder Cable Reeving.....	16
3-12	Hydraulic Hose routing	17
5-1	Wire Rope Components	23
7-1	VL Hydraulic Cylinder Assembly-exploded view	35
7-2	HVL 50124 Load Tube Assembly.....	36
7-3	HVL 50124T Load Tube Assembly	37

1 SAFETY

1.1 INTRODUCTION

Your Reimann & Georger Corporation Marine Products Aluminum Vertical Lift has been engineered to provide lifting performance, long term economics and safety advantages that no other type can match. However, even a well-designed and well-built lift can malfunction or become hazardous in the hands of an inexperienced and/or untrained user. Therefore, read this manual and related equipment manuals thoroughly before operating your lift to provide maximum safety for all operating personnel, and to get the maximum benefit from your equipment.



WARNING:

DO NOT OPERATE THIS LIFT WITHOUT STUDYING THIS ENTIRE MANUAL. FAILURE TO DO THIS CAN LEAD TO EQUIPMENT MISUSE WITH RESULTING SERIOUS PERSONAL INJURY AND/OR DAMAGE. CONTACT YOUR RGC® MARINE DEALER IF YOU HAVE ANY QUESTIONS.



WARNING:

DO NOT SERVICE THE HYDRAULIC LIFT WITH YOUR BOAT ON THE LIFT. DO NOT SERVICE THE HYDRAULIC LIFT WITH LOAD TUBES IN THE RAISED POSITION. DO NOT DISCONNECT ANY HYDRAULIC LINES UNLESS THE LIFT IS COMPLETELY LOWERED.

1.2 SAFETY DEFINITIONS

A safety message alerts you to potential hazards that could hurt you or others or cause property damage. The safety messages or signal words for product safety signs are **DANGER**, **WARNING**, and **CAUTION**. Each safety message is preceded by a safety alert symbol and is defined as follows:

DANGER: Indicates an imminently hazardous situation which, if not avoided, **will** cause death or serious injury. This safety message is limited to the most extreme situations.

WARNING: Indicates a potentially hazardous situation which, if not avoided, **could** result in death or serious injury.

CAUTION: Indicates a potentially hazardous situation which, if not avoided, **may** result in minor or moderate injury. It may also be used to alert against unsafe practices and property-damage-only accidents.

1.3 EQUIPMENT SAFETY LABELS

These labels warn you of potential hazards that could cause injury. Read them carefully. If a label comes off or becomes illegible, contact a Reimann & Georger Corporation dealer for a free replacement.

1.4 EQUIPMENT AND PERSONNEL SAFETY

1. Do not use the lift, control box, or the remote control if any item shows any signs of damage.
2. Do not expose the internal control box components or remote control to water or inclement weather conditions.
3. Understand the use of all controls and connections provided with the control box.
4. Never operate the lift with a substitute hydraulic power supply. Use only the control box provided with the lift.
5. Do not store any articles in the control box, as this can damage the pump or electrical system.
6. Do not allow persons other than authorized service personnel to repair any part of this equipment.
7. Do not exceed the rated maximum lifting capacity of this equipment.

8. Never try lifting anything other than a boat with this equipment.
9. Never allow people in the boat any time it is suspended above the water on the platform or when the lift is in use.
10. Do not stand or walk on the loading platform while it is in any raised position.
11. Do not allow anyone to swim or play under, near or on the lift at any time. Raise the bunks out of the water when leaving the lift unattended to allow swimmers to see its location.
12. Never use the lift to hang or store any auxiliary equipment such as boating hardware.
13. Never operate the lift during an electrical storm.



WARNING:

ALL ELECTRIC DRIVES MUST BE INSTALLED AND INSPECTED BY A CERTIFIED ELECTRICIAN IN ACCORDANCE WITH LOCAL ELECTRICAL CODES. THIS INSTALLATION MUST INCLUDE A PROPERLY WORKING GROUND FAULT CIRCUIT INTERRUPTER. (G.F.C.I.)



WARNING:

DO NOT STAND OR WALK ON THE PLATFORM WHILE IT IS IN ANY RAISED POSITION. THIS CAN CAUSE SERIOUS PERSONAL INJURY.

1.5 INSTALLATION SAFETY

1. Insure that all bolts and nuts are fastened securely prior to operation.
2. Insure the pulleys spin freely. If any pulley binds, replace it immediately.
3. Do not weld or otherwise modify the lift. Such alterations may weaken the structural integrity of the lift and void the warranty.
4. All lifting accessories such as pontoon brackets, pivoting bunks, and guide-ons, must be commercially manufactured, have a rated load capacity equal to that of the lift, and be properly maintained and installed.
5. Insure that the frame is level and square.
6. The following precautions must be observed when lifting any part of this equipment:
 - a. Be sure of your footing.
 - b. Bend your knees and lift with your legs.
 - c. Hold the equipment section close to your body when lifting.
7. Wear heavy leather gloves when handling wire rope. Insufficient hand protection when handling wire rope can cause personal injury.

1.6 OPERATING SAFETY

1.6.1 General

1. Never use this equipment beyond its rated capacity. This can damage the lift and/or boat with resulting serious personal injury.
2. Before allowing anyone to operate the lift, be certain they fully understand the proper operating procedure.
3. Completely remove any user or dealer installed locking devices before operating the lift.

4. Follow the Pre-Lifting Checklist before operating.
5. Do not try lifting or launching your boat in rough water conditions. This can damage your boat and/or the lift.
6. The boat must be secured on the lift before raising or lowering. Failure to do this can cause equipment damage and/or serious personal injury.
7. Keep people and pets clear during operation of the lift.
8. Keep fingers and clothing clear of all moving parts.
9. Check the lift periodically for frayed cables and/or binding pulleys.
10. Do not attempt to make any adjustments on the lift while it is being operated.
11. Do not operate the lift under the influence of drugs, alcohol, or medication.
12. Never use the lift to hang or store any auxiliary equipment such as boating hardware.
13. A clear visual path is required when using a remote transmitter. Obstacles, radio frequency interference, and weak transmitter batteries will degrade the performance and range of your remote transmitter.
14. Never adjust or service the lift during operation or while connected to the control box.
15. Do not adjust the components in the control box while operating the lift.
16. Completely lower the platform before performing any type of maintenance or repair.
17. Never allow anybody to work in or on the boat when it is suspended above the water on the lift.
18. At end of operation, secure the control box and the lift to prevent unauthorized use. Never assume you will find the equipment in the same condition in which you left it.
19. Never operate the remote control or hydraulic power unit when connecting or disconnecting hydraulic hoses.
20. Do not operate the lift when under the influence of drugs, alcohol, or medication.

1.6.2 Safety When Raising the Boat

1. Do not try to raise the boat beyond the maximum lifting height of the platform.

1.6.3 Safety When Lowering the Boat

1. Do not continue lowering the platform after the boat floats freely. Excessive slack in winch cable may cause binding.

1.7 MAINTENANCE AND STORAGE SAFETY

1. At least once a year, the lift must be thoroughly inspected as described in the Maintenance chapter of this manual.
2. Completely lower the platform before performing any type of maintenance or repair.



WARNING:

NEVER ALLOW ANYBODY TO WORK IN OR ON THE BOAT WHEN IT IS SUSPENDED ABOVE THE WATER ON THE LIFT.

3. Immediately replace any components found to be defective as described in Chapter 5—Inspection and Maintenance.

2.3 OPTIONAL EQUIPMENT

The following options are available which enable you to customize your lift for your particular operation. Installation instructions are provided as part of each option kit.

1. **Acrylic Canopy**— Boats tucked neatly under the heavy duty canopy are protected from the elements, reducing the need for boat coverings. Various canopy sizes and colors are available.
2. **Full Length Pivoting Bunks**—Full length cushioned bunks cradle and center the boat for secure lifting. Provided as standard equipment.
3. **Full Length Guide-On**—Cushioned guide-ons make entering the lift easy in various water conditions.
4. **Motor Stop**—Assists in positioning boat on the lift for balanced lifting.
5. **VL Transport Kit**—Makes installation and removal of boat lift easier. You can purchase the complete kit or desired components.
6. **Pontoon Deck Brackets**—These brackets are designed to lift pontoon boats from under the deck. The vertical leg bumper kit is included which supplies carpeted side bumpers. Wood for bunks is not supplied.
7. **Pontoon Cradles**—Cradle brackets designed for lifting pontoon boats from under the pontoons. The vertical leg bumper kit is included which supplies carpeted side bumpers. Wood for bunks is not supplied.
8. **Deep Water Extension Legs**—Adjustable legs available in pairs with bracing. Standard lengths are 4', 6', 8', and 10'.
9. **VL Upper / Lower Bumper Kit**—This cushioned wood kit mounts onto your lift in key locations to protect your boat while entering and exiting the lift in various water conditions. This is both a “stand alone” kit and a kit automatically supplied with the pontoon deck brackets and pontoon cradles.
10. **VL Hydraulic Power Unit Shelf**- This kit includes a shelf frame, support braces and hardware to attach to the leg ‘C’ on the lift.

3 INSTALLATION AND SETUP

3.1 PRE-INSTALLATION CHECKS

1. Do not assemble the lift if any part shows any sign of damage.
2. Do not weld or otherwise modify the lift. Such alterations may weaken the structural integrity of the lift and void the warranty.
3. All lifting accessories such as pontoon brackets, pivoting bunks, guide-ons, and slings shall be commercially manufactured, have a rated load capacity equal to that of the lift, and be properly maintained and installed. Consult the manufacturer's separate instructions provided for these accessories.



WARNING:

ALL ELECTRIC DRIVES MUST BE INSTALLED AND INSPECTED BY A CERTIFIED ELECTRICIAN IN ACCORDANCE WITH LOCAL ELECTRICAL CODES. THIS INSTALLATION MUST INCLUDE A PROPERLY WORKING GROUND FAULT CIRCUIT INTERRUPTER. (G.F.C.I.)



WARNING:

DO NOT SERVICE THE HYDRAULIC LIFT WITH YOUR BOAT ON THE LIFT. DO NOT SERVICE THE HYDRAULIC LIFT WITH LOAD TUBES IN THE RAISED POSITION. DO NOT DISCONNECT ANY HYDRAULIC LINES UNLESS THE LIFT IS COMPLETELY LOWERED.

3.2 PRIOR TO SETUP

The part reference numbers and letters used in the subassembly drawings of sections 3.3 through 3.9 are the same as those shown in Figure 3-1 and listed in the parts lists of Chapter 7

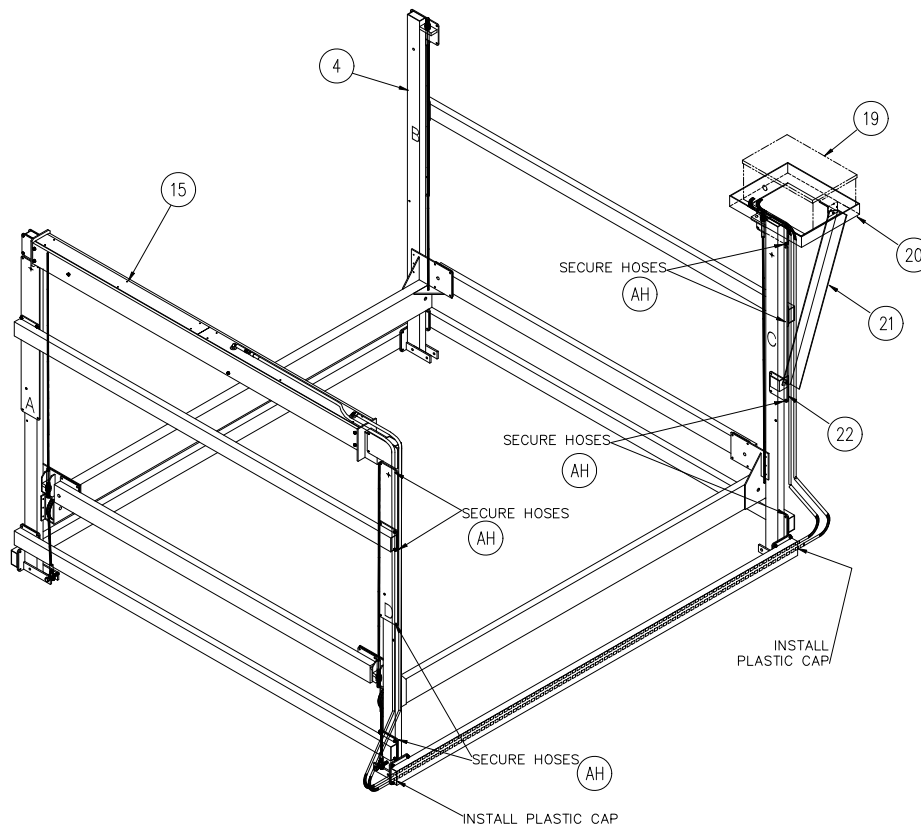

Figure 3-1
Hydraulic Vertical Lift Frame & Platform Assembly

The lift may be placed so that columns B & C are on your dock side as shown in Figure 3-2. The hydraulic beam assembly remains on the outside of the lift. The hydraulic power unit can be located on the dock or with optional power unit shelf bracket mounted on column C.



WARNING:

Boat must be positioned properly on lift. If weight of boat is not equal on both front and rear load tubes, the lift will not operate properly and also, damage will occur to the lift.

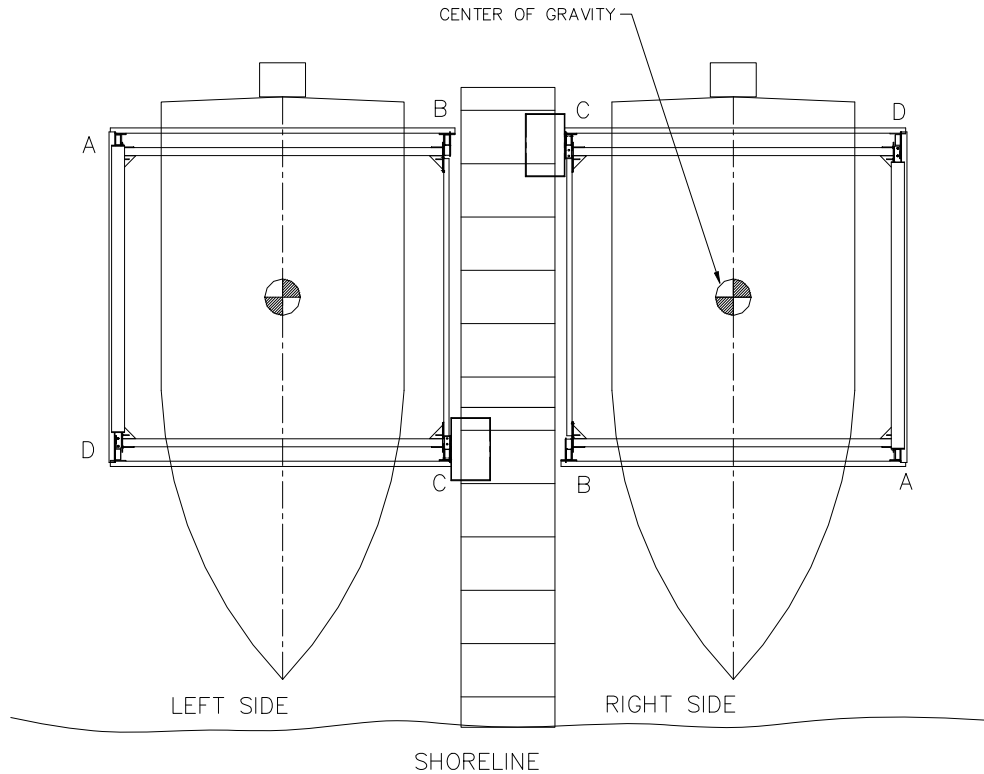

Figure 3-2
Lift / Dock Placement Options



CAUTION:

INSERT ALL BOLTS FROM THE INSIDE OF THE LIFT TO PREVENT DAMAGE TO YOUR BOAT. THE NUTS FASTEN ONTO THE OUTSIDE FACE OF THE LIFT. THE ONLY BOLTS THAT MAY BE INSERTED FROM THE OUTSIDE OF THE LIFT ARE THOSE ON THE BOTTOM PARTS OF THE BRACES.

3.3 PLATFORM DISASSEMBLY

The lift must be disassembled to convert the lift to a Hydraulic Vertical Lift.

The cables in the A-B and C-D Load tubes must be reeved differently for the new hydraulic vertical lift. Also the cables in the A-D and B-C spreader tubes must be removed for the new hydraulic vertical lift.

1. Refer to Figure 3-3. Disconnect all cables from the top and bottom of each leg.
2. Remove assembled platform from lift. Place the platform on the ground to be disassembled.
3. Loosen and remove all 3/8-16 x 1" long bolts from A & D corner.
4. Loosen and remove the 3/4" hex nut and lock washer from each end of the A-D & B-C spreader tubes.
5. Remove the 3/4" hex bolt and also remove the nylon cable sheave, bushing & cable from the spreader tubes. These items will no longer be used on the hydraulic vertical lift.

3.4 A-B & C-D LOAD TUBE ASSEMBLY

1. Refer to Section 7, C-D Load Tube Assembly 3641364 drawing. Loosen and remove the $\frac{3}{4}$ -10 hex nut and lock washer. Carefully remove the $\frac{3}{4}$ -10 hex bolt and remove the two cable sheave and bushing from each end of the tube. Refer to the drawing and remove the cable that is no longer used. (Note: This cable is used in the A-B load tube, see step 4. Also the two cable sheaves removed will be used in step 4).
2. Refer to Section 7, C-D Load Tube Assembly 3641364 drawing. Install one cable sheave (detail 8) & bushing (detail 7) at each end of the C-D load tube as shown on drawing.
3. Refer to Section 7, A-B Load Tube Assembly 3641362 drawing. Loosen and remove the $\frac{3}{4}$ -10 hex nut and lock washer. Carefully remove the $\frac{3}{4}$ -10 hex bolt and remove the cable sheave and bushing from each end of the tube. Remove the hoist cable from load tube, no longer used. Install the cable previously removed in step 1 from C-D load load as shown in 3641362 drawing.
4. Refer to Section 7, A-B Load Tube Assembly 3641362 drawing. Install one cable sheave (detail 2), bushing (detail 3) & spacer (detail 16) at each end of the A-B load tube as shown on drawing. (Note: Use cable sheave previously removed from C-D load tube in step 1).

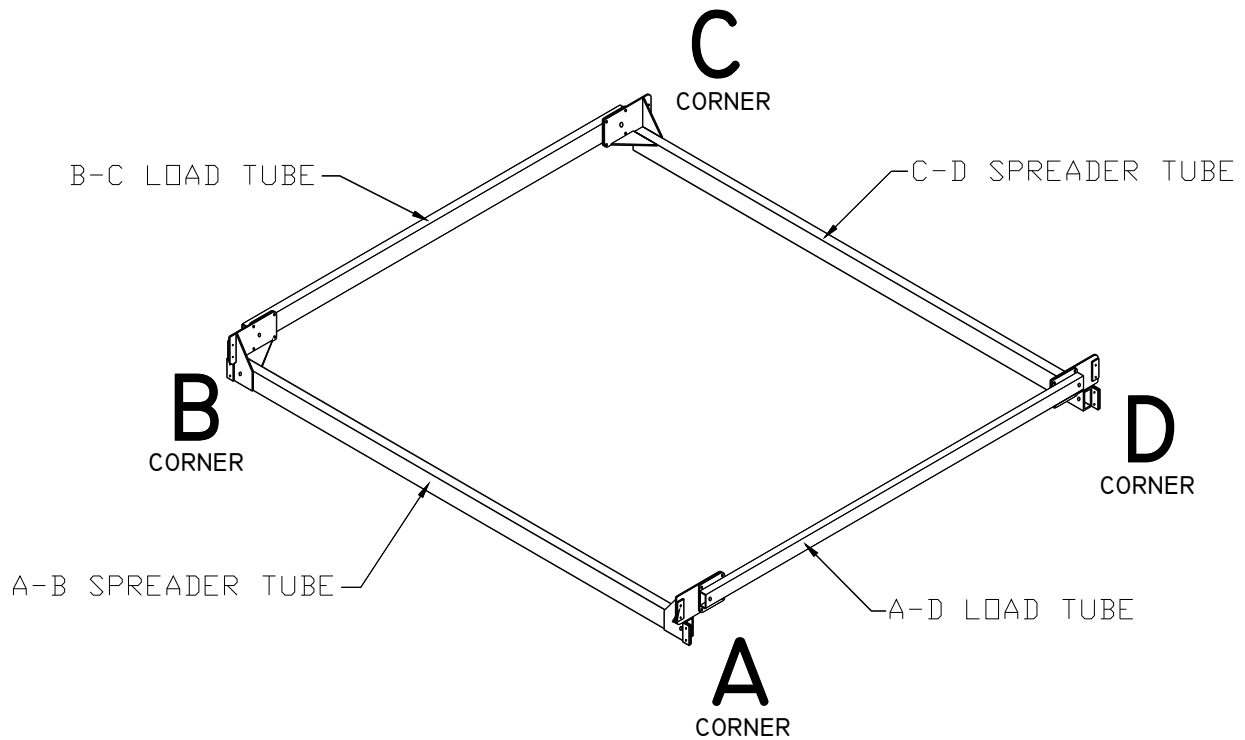

Figure 3-3
Platform Disassembly

3.5 'B' LEG CONVERSION

The lift must be disassembled to convert the lift to a Hydraulic Vertical Lift.

1. Refer to Figure 3-4. Loosen and remove all bolts from horizontal tubes that attach to the 'B' leg of the lift. Remove and discard the old 'B' leg and replace with the new 'B' leg supplied (detail 4).
2. Attach all horizontal tubes to the new 'B' leg previously removed and tighten all bolts.

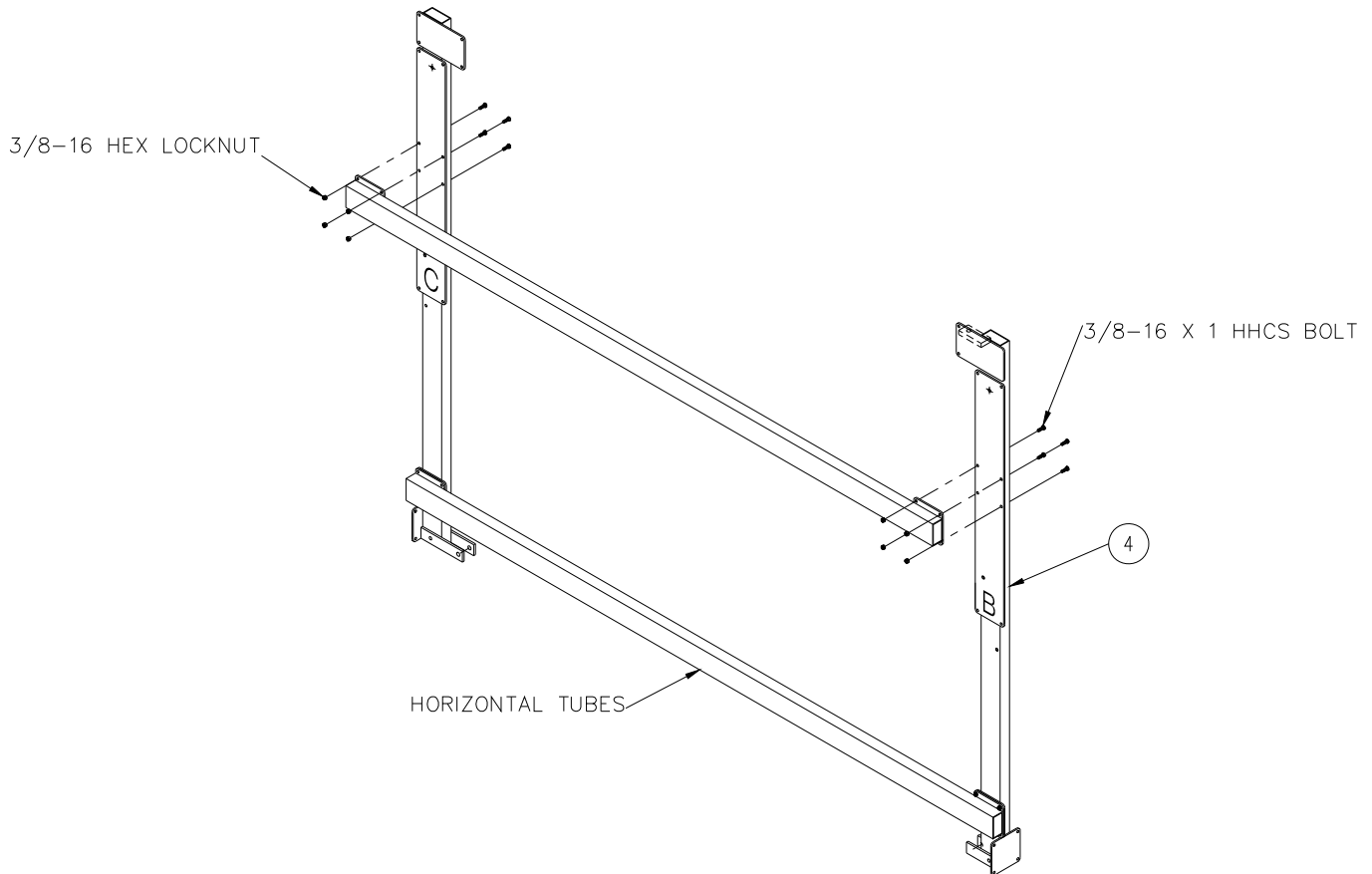

Figure 3-4
C-B Side Frame Assembly

3.6 PLATFORM ASSEMBLY

1. Refer to Figure 3-5. Position both load tubes and spreader tubes on the ground as shown in the diagram.
2. Attach the B-C spreader tube to the A-B & B-C load tubes. Use the 3/8-16 x 1" long hex bolts and lock nut.
3. Attach the A-D spreader tube to the load tubes. Install the cable anchor weldment (detail 17) between the spreader and the load tube. Use 3/8-16 x 1-1/4" long hex bolts to attach this spreader tube, anchor & load tube together.



CAUTION:

INSERT ALL BOLTS FROM THE INSIDE OF THE LIFT TO PREVENT DAMAGE TO YOUR BOAT. THE NUTS FASTEN ONTO THE OUTSIDE FACE OF THE LIFT. THE ONLY BOLTS THAT MAY BE INSERTED FROM THE OUTSIDE OF THE LIFT ARE THOSE ON THE BOTTOM PARTS OF THE BRACES.

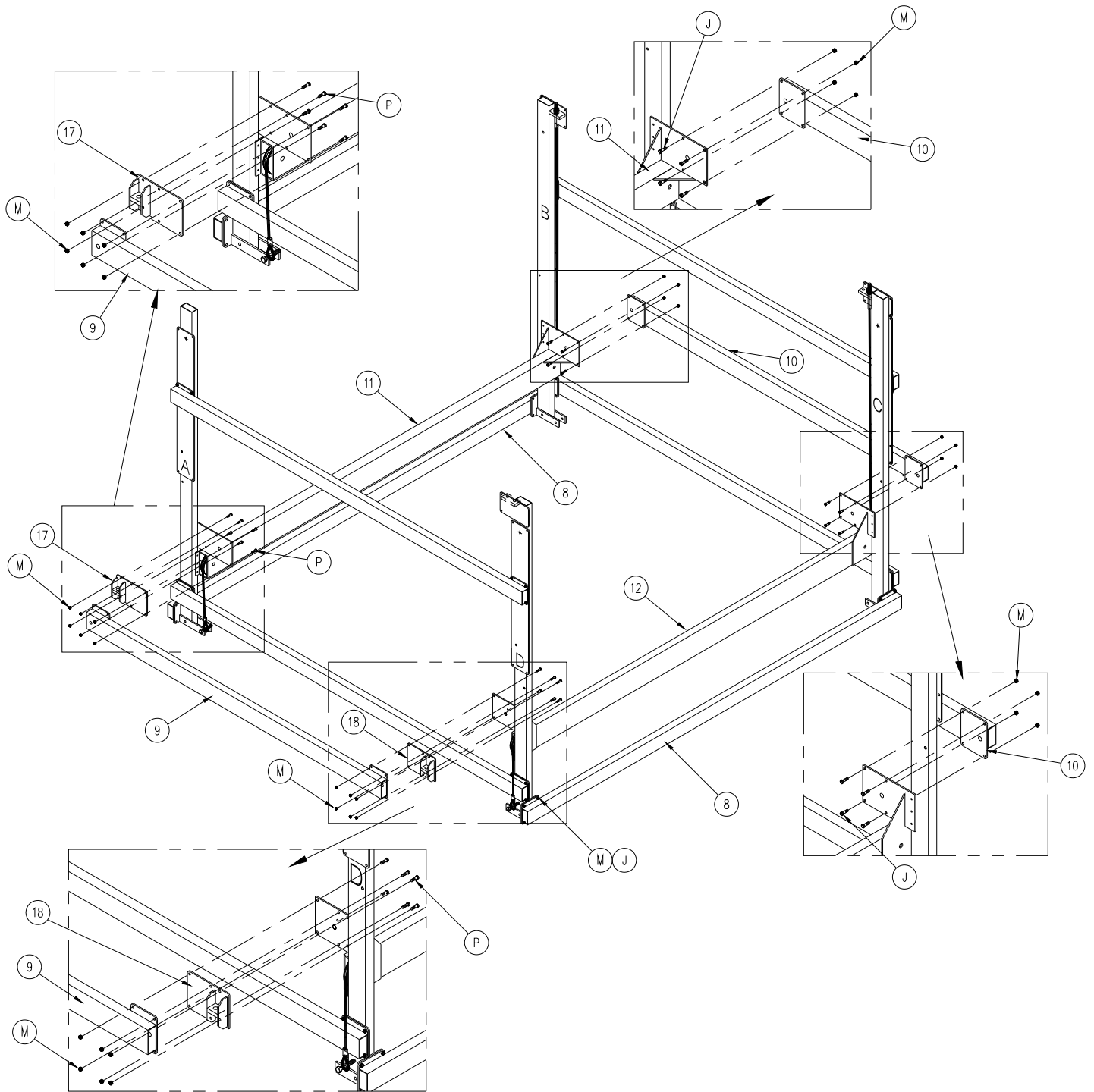

Figure 3-5
Platform Assembly – Isometric

3.7 MOUNTING THE PLATFORM TO THE FRAME

1. Insure all platform fastenings are tight before mounting onto the frame.
2. Lift one of the frame sides and position it along a spreader tube side of the platform.
3. Place a platform corner onto each of the foot plates so that the frame side stands.
4. Repeat Steps 2 and 3 for the other side of the lift.



CAUTION:

THE LOAD AND SPREADER TUBES OF THE PLATFORM ARE ALREADY REEVED. WHEN PLACING THE ASSEMBLED PLATFORM INTO THE FRAME, INSURE THE CABLE LOOPS ARE PASSING OVER THE SHEAVES AND POINTING TOWARDS THE BOTTOM BRACKET OF EACH VERTICAL LEG. EQUIPMENT MALFUNCTION AND DAMAGE WILL RESULT IF THE PLATFORM IS NOT ORIENTED THIS WAY.

5. Fasten a long horizontal tube across each end to connect the two sides using hardware shown in Figure 3-4. **DO NOT TIGHTEN.**
6. Square the frame by adjusting the verticals to achieve the same measured distance between them at both top and bottom. Refer to “X” Dim. in Figure 3-6. Tighten all fasteners. Remeasure and align if necessary.
7. Install the eight (8) plastic caps provided onto the tops of the four vertical legs and the ends of the upper short horizontal tubes.

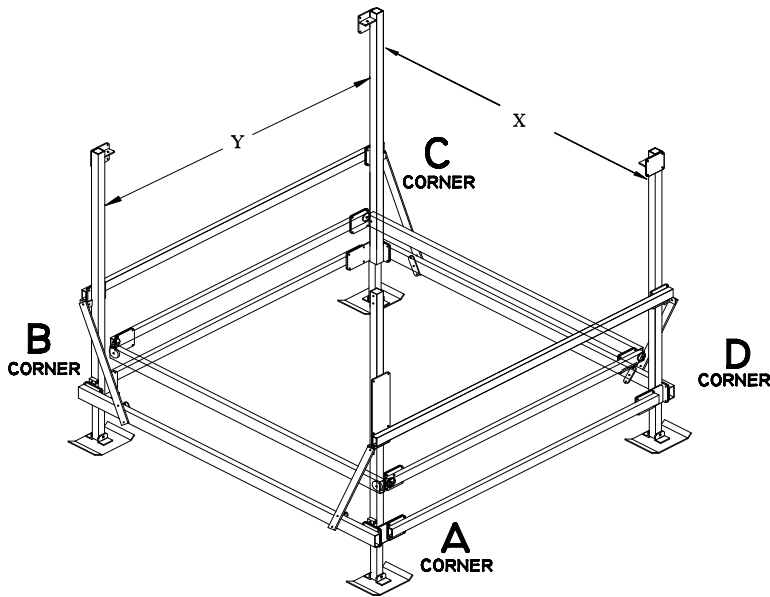

MODEL	“X” DIM	“Y” DIM
HVL70124	124 IN.	114 IN.

Note: Values shown are approx.

**Figure 3-6
Frame Squaring Assembly / Table**

3.8 MOUNTING THE LOWER DIAGONAL BRACES

1. Position a lower diagonal brace on the inside of vertical leg “B” as shown in Figure 3-7. Loosely fasten with hardware shown.
2. Position the opposite end along the long horizontal tube so that the tube is situated between the two holes located in the lower diagonal brace. Place a 3-hole plate onto the outside face of the horizontal tube.
3. Align the holes and fasten in place.
4. Repeat Steps 1 through 3 for each corner.



CAUTION:

THE FOUR LOWER DIAGONAL BRACES ARE MOUNTED ONLY TO THE TWO LONG HORIZONTAL TUBES. NEVER TRY TO MOUNT THESE BRACES TO ANY OF THE SHORT HORIZONTAL TUBES.

5. Insure the frame is square and that it satisfies the dimensions shown in Figure 3-6. About 1/4 to 1/2 inch difference between the upper and lower measurements is permitted.

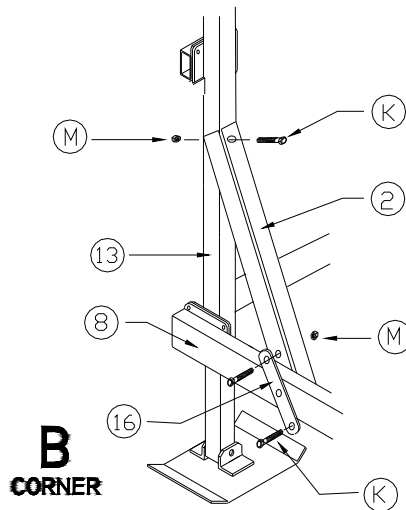

Figure 3-7
Lower Diagonal Brace Assembly

3.9 PLATFORM REEVING AND ADJUSTMENT

1. Position the platform near the bottom end of its lifting range. Insure the platform is level.
2. Refer to Figure 3-8. The load tubes are already reeved. Fasten the cable end loops to the bracket provided at the bottom of vertical legs A & D.



CAUTION:

DO NOT “JAM TIGHT” THESE LOWER CABLE ANCHORS OR YOU WILL BREAK OFF THE BRACKET PLATES.



CAUTION:

WEAR HEAVY LEATHER GLOVES WHEN HANDLING WIRE ROPE. FAILURE TO DO THIS CAN CAUSE SERIOUS PERSONAL INJURY.

3. Using a 7/8” open-end wrench, tighten the cable studs opposite the cable end loops in the following order. The following step numbers correspond to the step numbers shown in Figure 3-8.
 - Step 1: Tighten down the nut to add tension to the A-B Load tube cable.
 - Step 2: Tighten down the nut to add tension to the C-D Load tube cable.
4. Add and tighten the jam nuts to the cable nuts to lock the position.
5. During operation, when the platform is being lifted, it is normal for the cable in the A-B & C-D load tube to alternate from being tense to going slack. If you notice this, it is not necessary to further tighten down the nuts.
6. If the boat is not lifting level because the stern is lifting higher or lower than the bow, the load tube cables are not tight enough. Repeat the first two substeps under Step 3 above.

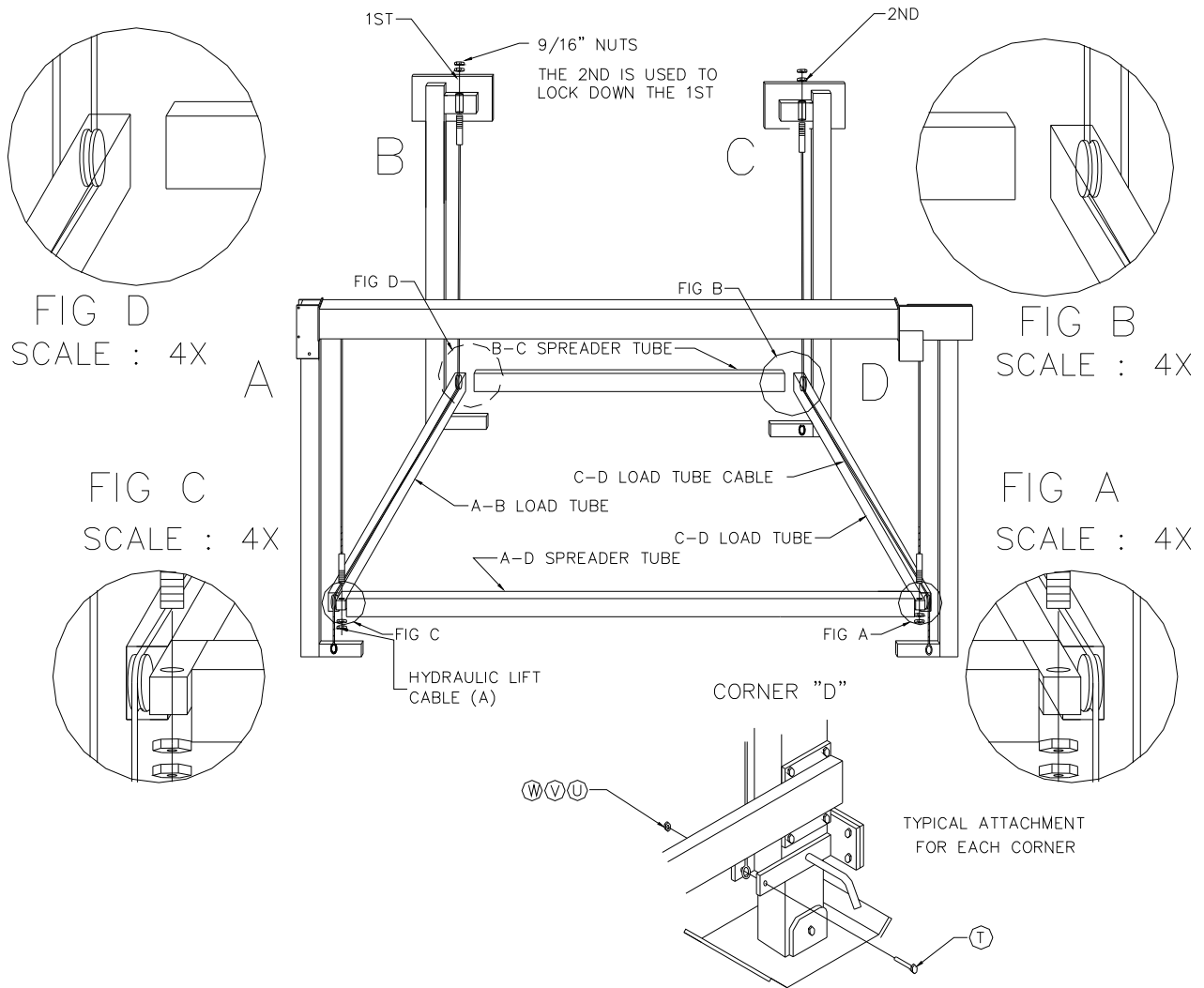

**Figure 3-8
Cable Reeving & Adjustment**

3.10 VL HYDRAULIC CYLINDER ASSY MOUNTING

1. Refer to Figure 3-9. Install hydraulic cylinder assembly to vertical leg “A” and “D”. Use fasteners detail A thru H and install fasteners detail AA, AB, AC & AD.

3.11 VL HYDRAULIC SHELF FRAME (OPTIONAL)

1. Refer to Figure 3-10. Install VL hydraulic power unit shelf frame to leg “D”. Use fasteners AE, AF & AG to attach the shelf frame and diagonal brace.

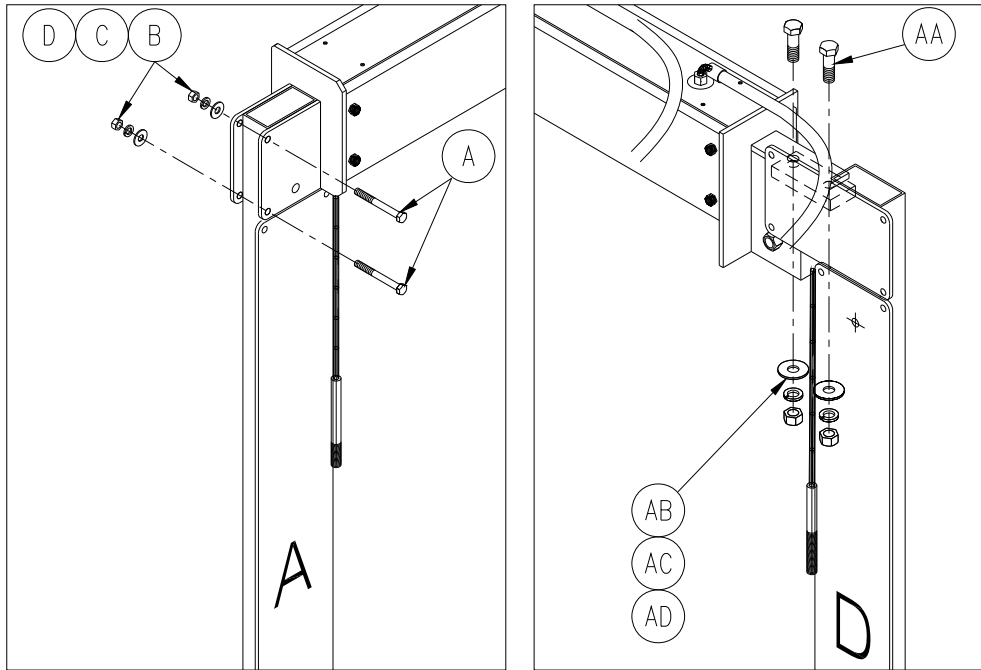

Figure 3-9
VL Hydraulic cylinder Mounting

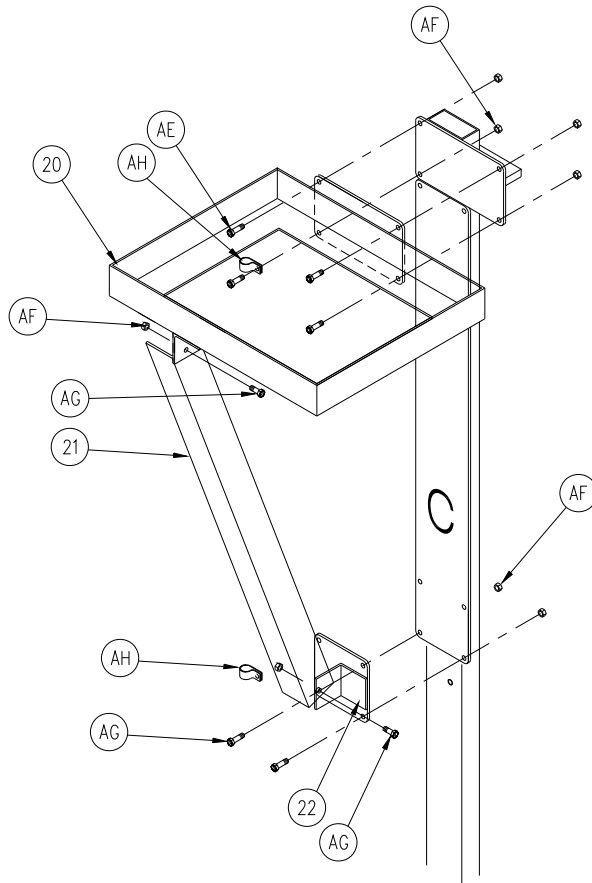

Figure 3-10
VL Hydraulic Power Unit Shelf Mounting

3.12 REEVING THE HYDRAULIC CYLINDER ASSEMBLY

4. Using a 1-1/8" open-end wrench, tighten the cable studs on the cable. The following step numbers correspond to the step numbers shown in Figure 3-11.
 - Step 1: Tighten down the nut to add tension to the lift at vertical leg A.
 - Step 2: Tighten down the nut to add tension to the C-D Load tube cable.
7. Add and tighten the jam nuts to the cable nuts to lock the position.
8. During operation, when the platform is being lifted, it is normal for the cable in the A-B & C-D load tube to alternate from being tense to going slack. If you notice this, it is not necessary to further tighten down the nuts.
9. If the boat is not lifting level because the stern is lifting higher or lower than the bow, the load tube cables are not tight enough. Repeat the first two substeps under Step 3 above.

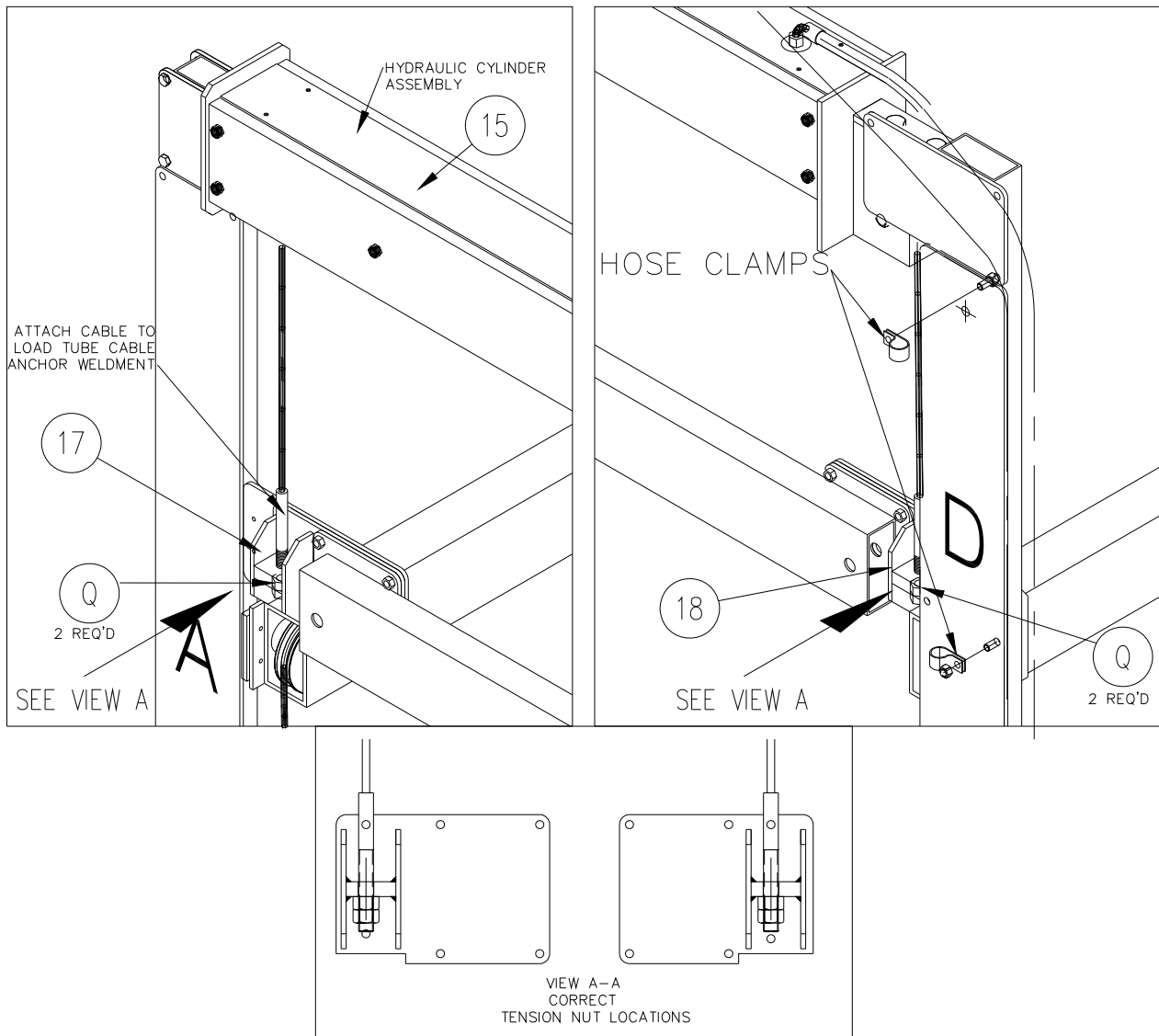

Figure 3-11
Hydraulic Cylinder Cable Reeving

3.13 HYDRAULIC HOSE ROUTING

Refer to Figure 3-12. The hydraulic hoses are assembled onto the hydraulic cylinder assembly. You must route and secure the hydraulic hoses down along the vertical column C, through the lower horizontal tube, up along column D and connect into the Power unit.

Clamps have been provided to attach the hoses to existing mounting holes on the lift. Plastic caps have been provided to protect the hoses inside the lower horizontal tube.

Caution: When routing hoses, make sure the hoses are protected from damage around sharp corners and possible damage from your boat.

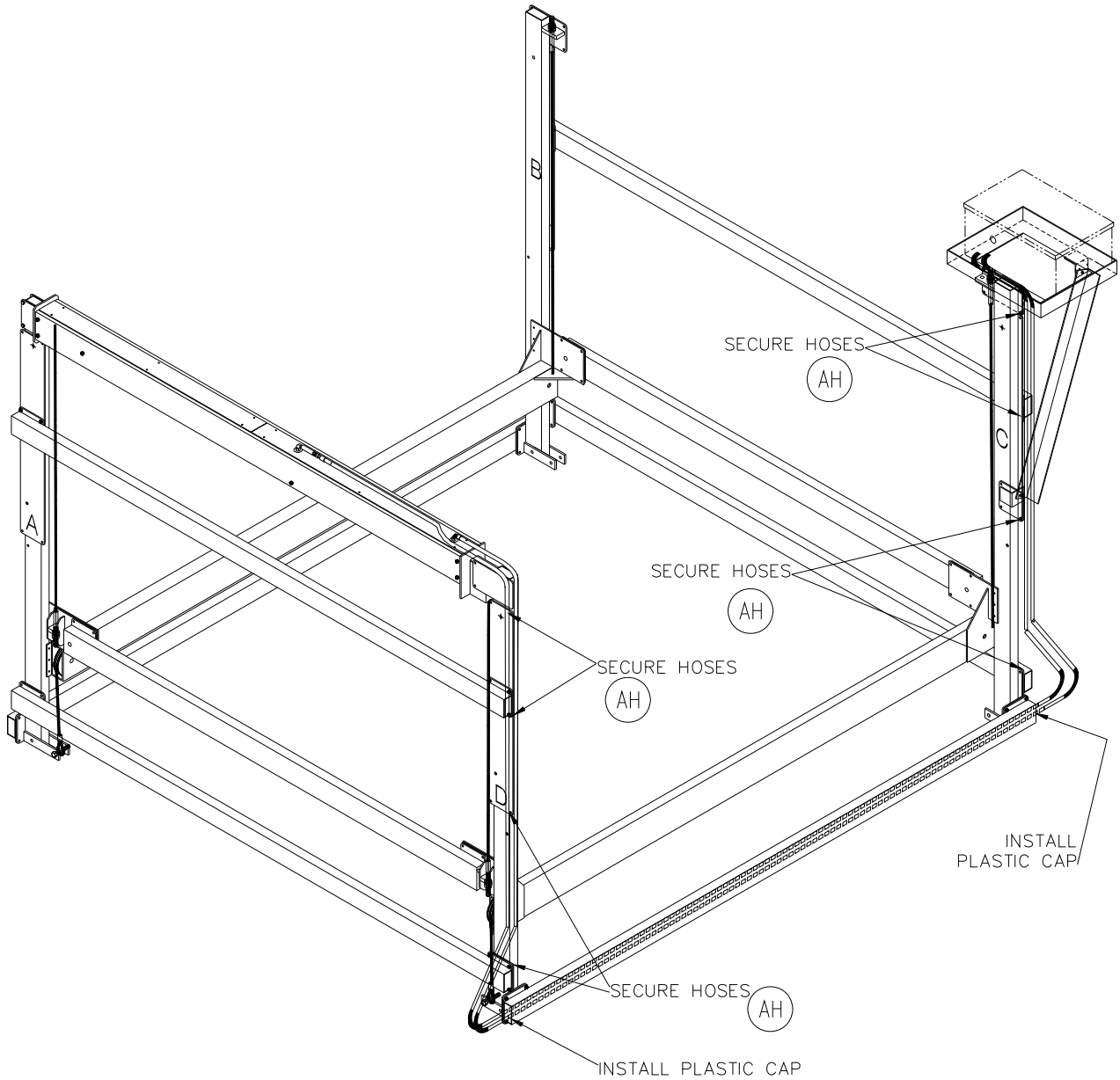

Figure 3-12
Hydraulic Hose Routing

3.14 MOVING LIFT TO OPERATING POSITION

1. The following precautions must be observed when moving your lift for any reason:
 - a. Be sure of your footing.
 - b. Bend your knees and lift with your legs.
 - c. Hold the lift section close to your body when lifting.
2. After moving your lift to the operating position, insure that the frame is square and that the lift sets level.



CAUTION:

SEVERE OUT OF LEVEL INSTALLATION MAY CAUSE BINDING, RESULTING IN EQUIPMENT DAMAGE.



CAUTION:

FRAME MUST BE SQUARE TO PREVENT DAMAGE AND/OR IMPROPER FITTING OF CANOPY FABRIC IF SO EQUIPPED.

3. Verify frame is square by measuring the diagonal distance from the outside of frame corner to opposite corner. Repeat for alternate corners. The **difference between the two measurements shall not exceed 1/4 of an inch.**

Frame Diagonal Measurement Diagram
(Measure to Outside Corners)

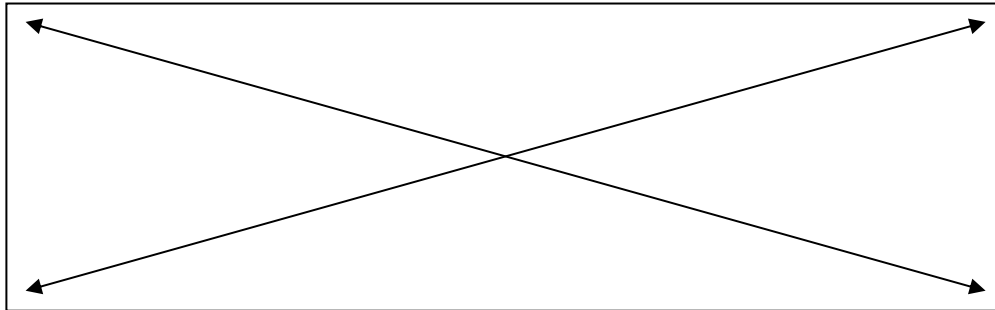

4 OPERATION

4.1 BEFORE OPERATING THE LIFT

1. Review and follow all the safety precautions given in Chapter 1.
2. Do not use the lift if it shows any signs of damage.
3. Insure that all bolts and nuts are fastened securely prior to operation.
4. Ensure that the frame is square and that the lift sits level.



WARNING:

IF THE FRAME IS NOT SQUARE OR THE LIFT IS NOT LEVEL, BINDING MAY RESULT. THIS CAN CAUSE PERSONAL INJURY AND/OR EQUIPMENT DAMAGE.

5. Never try lifting anything other than a boat with this lift.



WARNING:

NEVER TRY TO USE THIS EQUIPMENT BEYOND ITS RATED CAPACITY. THIS CAN DAMAGE THE LIFT AND/OR BOAT RESULTING IN PERSONAL INJURY.

THE BOAT MUST BE PROPERLY POSITIONED ON THE LIFT BEFORE DOING ANY RAISING OR LOWERING. FAILURE TO DO THIS CAN CAUSE PERSONAL INJURY AND/OR EQUIPMENT DAMAGE.

6. Never try to lift or launch your boat in rough water conditions. This can damage your boat and/or the lift.
7. Follow the Pre-Lifting Checklist before operating.
8. Read and know the instructions and insure that everyone understands the proper operating procedure.
9. Understand the use of all the controls and connections provided with the power supply and the remote transmitter.

4.2 TESTING LIFT OPERATION

After the lift installation is complete, it is important to test it for proper functioning before any load is applied. Proceed as follows:

1. Use the up/down switch inside the control box to cycle the lift up and down. Insure that the hydraulic hoses are not binding or being pinched by any part of the lift.



WARNING:

DO NOT STAND OR WALK ON THE LIFT PLATFORM WHILE IT IS IN ANY RAISED POSITION. THIS CAN CAUSE SERIOUS PERSONAL INJURY.

2. The loading platform should move up and down smoothly without excessive stress or squeaking.
3. After cycling the lift a couple of times, inspect all hardware to insure that they are still secure and tight. Also test the remote control and underwater lighting system.
1. Contact your authorized dealer if the hydraulic system fails to perform as described in this section. Do NOT tamper with either system.

4.3 TESTING LIFT WITH REMOTES

3. To unlock the remotes, press the two blue buttons simultaneously, this will unlock the unit. To lock the remote, press the two blue buttons simultaneously will lock the unit.
4. Press the 'UP' button to make the lift go in the upward direction. Press 'DOWN' to make the lift go in the downward direction.

4.4 RAISING AND LOWERING THE BOAT

1. Position the boat so that the boat's center of gravity is between forward load tube and rear foot.
2. Carefully raise the platform until the bunks "capture" the boat. Stop the lift and check to see that the bunks have automatically positioned themselves to the shape of the hull, as they were installed to do in Chapter 3. If this has occurred, continue bringing the boat out of the water until it is about 1 foot above the surface.



WARNING:

NEVER ALLOW PEOPLE IN THE BOAT ANY TIME IT IS SUSPENDED ABOVE THE WATER ON THE LIFT.

3. Keep fingers and clothing clear of all moving parts. Keep people clear during operation of the lift.
4. Stop the lift again and check the stability of the lift. Insure that it is remaining level and will not topple over.
5. Continue lifting the boat, closely observing the position of the lift, until the platform is in the fully upright and over center position.
6. Remove the boat from the lift and check to see that the lift is still level. If not, the legs will have to be re-adjusted.



CAUTION:

ALWAYS ADJUST THE HEIGHT OF THE LIFT TO LIMIT WAVE ACTION AGAINST THE HULL. WAVE ACTION CAN SERIOUSLY DAMAGE THE LIFT AND/OR YOUR BOAT.

7. Two weeks after installation, check to see that the lift is still level, as it may have settled over time. Readjust the legs as described above and repeat this inspection and adjustment procedure at the frequency found necessary.
8. After removing the boat from the lift, re-tighten the bunk bolts as required.

4.5 SECURING LIFT WHEN NOT IN USE

1. Make the lift visible by leaving the platform in any elevated position when it is not loaded with a boat. This prevents the lift from being a hidden underwater obstruction, and protects the bunks from prolonged water immersion.

WARNING: Do not store with bunks in the water, raise platform out of water when not used to prevent bunk damage due to wave and rough water.

2. Lock out your control box to prevent unauthorized use when your boat lift is unattended. Never assume you will find the lift in the same condition that you left it.
3. When storing the boat on the lift, the following additional precautions must be observed:
 - a. When storing the boat, the platform must be in the upright over center gravity lock position for maximum safety. The over center position will prevent the boat from lowering if any hydraulic leak occurs.
 - b. Position the boat on the platform so that the boat's center-of-gravity is between the forward load tube and the rear foot plates when in the down position.
 - c. Prevent rainwater from accumulating in your boat when leaving it on the lift for long term storage. A boat that has water in it from a rainstorm could exceed the recommended weight capacity of the lift. **Just 1 gallon of water weighs over 8 pounds.** Be sure to remove the plug while the boat is up on the lift. Make sure you replace the plug prior to launching your boat.

5 INSPECTION AND MAINTENANCE

5.1 GENERAL MAINTENANCE RULES

1. Do not allow persons other than authorized service personnel to repair this equipment.
2. If slings are used, inspect them for deterioration. Replace them immediately if they are worn.
3. Do not weld or otherwise modify the lift. Such alterations may weaken the structural integrity of the lift and invalidate your warranty.
4. Completely lower the lift before performing any type of maintenance or repair.



WARNING:

NEVER ALLOW ANYBODY TO WORK IN OR ON THE BOAT WHEN IT IS SUSPENDED ABOVE THE WATER ON THE LIFT.



WARNING:

BEFORE STARTING ANY MAINTENANCE ON THE LIFT, DISCONNECT AND LOCK OUT THE POWER SUPPLY TO PREVENT ACCIDENTAL OPERATION.

5. Immediately replace any components found to be defective.



CAUTION:

POOR OR IMPROPER MAINTENANCE CAN LEAD TO EQUIPMENT DAMAGE OR FAILURE.

5.2 WIRE ROPE INSPECTION PROCEDURE

Inspect the wire rope prior to each use for signs of wear, damage, or pinching. Inspect the entire wire rope working length. Thoroughly inspect the rope sections that pass over sheaves or drums, or that make opposing turns. Inspect wire rope and end attachments carefully. While inspecting, examine sheaves, guards, guides, drums, flanges, and other surfaces contacting wire rope during operation. Correct any condition harming the rope in use or other damage or worn surfaces at this time.



CAUTION:

WEAR HEAVY LEATHER GLOVES WHEN HANDLING WIRE ROPE. INSUFFICIENT HAND PROTECTION WHEN HANDLING WIRE ROPE CAN CAUSE PERSONAL INJURY.

Remove and immediately replace wire rope with one or more of the following defects:

1. Corrosion
2. Broken wires:
 - (a) One or more valley breaks. A valley break is a wire break occurring in the valley between two adjacent strands.
 - (b) Six randomly distributed broken wires in one rope lay. A rope lay is the length of rope along which one strand makes a complete revolution around the rope. See Figure 5-1. Keeping the rope clean and wound evenly on the winch drum will increase its life and efficiency.
3. Abrasion: Scrubbing, flattening or peening causing loss of more than one-third of the original diameter of the outside wires.
4. Kinking: Severe kinking, crushing, bird caging or other damage causing distortion of the rope structure. Bird caging is a bulging in the cable caused by the individual wires becoming untwisted. This untwisting of individual wires is usually caused by impact loading on the cable (such as a sudden stop).

5. Heat damage: Evidence of any heat damage caused by a torch or by contact with electrical wires.

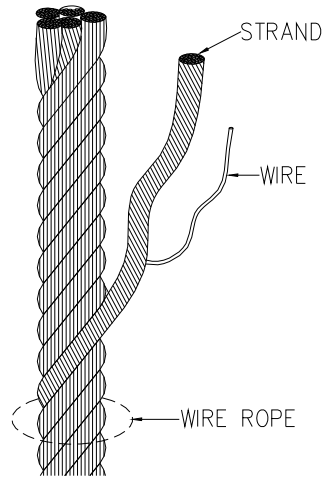

Figure 5-1.
Wire Rope Components

6. Reduction of more than 1/64 inch from a nominal 5/16-inch or less diameter cable. Reduction of more than 1/32 inch from a nominal 3/8-inch to 1/2-inch diameter cable.

5.3 ANNUAL INSPECTION

At least once a year, the lift must be thoroughly inspected using the following procedure.



WARNING:

DO NOT ALLOW ANYBODY TO USE THE LIFT UNTIL THIS MAINTENANCE IS COMPLETED.

1. Tighten all bolts.
2. Clean cylinder rods.
3. Check that all the pivot pins are lubricated properly.
4. Check frame thoroughly for defects.
5. Inspect all hydraulic lines, fittings and hoses for leaks and risks of rupture as follows:
 - a. Inspect each hydraulic line, fitting, and hose for breaks, cracks, worn spots, bulges, chemical attack, kinks or any other damage. Never try to stop any detected leak with any body parts. Do not put your face close to suspected leaks. Hold a piece of cardboard close to suspected leaks and then inspect the cardboard for signs of hydraulic oil.
 - b. Replace a damaged line, fitting or hose immediately. Never repair the part.

5.4 BATTERY MAINTENANCE

1. Use a 12 volt, group 27 marine deep-cycle battery with a minimum of 500 CCA, or with a reserve capacity of 160 amp hours or more. We recommend the following batteries: U.S. Battery Model 27 TMX, Trojan Battery Model 27 TMX or Rolls Battery Engineering Model 27112XJM. Reserve capacity is the most important feature.
2. The lift has an energy capacity of about 20 full cycles using a new battery with a reserve capacity of 160 amp hours. However, avoid dipping below 50% battery capacity because the solar panel will have trouble recovering from such a deep draw. For constant usage, we recommend that the battery be hooked up to an AC charger on a full time basis. We

recommend the following chargers: Guest Charge Pro Model 2608 (6 Amp) or Guest Charge Pro Model 2611 (10 Amp).

3. The following table lists maximum monthly full lifting cycles (down and up), using a single solar panel, to keep the battery capacity at a steady state energy level. The capacity of the battery will allow for additional cycles for any particular month. The values assume all-day exposure with typical seasonal weather.

Month	Cloudy northern climate	Sunny southern climate
January	2 cycles	27 cycles
February	8	29
March	14	29
April	18	31
May	21	27
June	22	25
July	24	28
August	24	31
September	19	29
October	12	29
November	4	28
December	1	25

4. If the solar panel does not keep the battery charged, try any of the following:
 - a. Move the solar panel to an area with less obstructed sunlight.
 - b. Add a second solar panel, or add an a/c charger.
 - c. Booster charge the battery at mid season.
5. Check water level in battery every three months. If the water level is low, fill it up with distilled water. Booster charge the battery with a 2A charge using a 10A charger in the beginning and end of the season.

5.5 REMOTE CONTROL INFORMATION

The remote transmitter can de-program due to either a power loss (dead battery) or electrical interference, which will require re-programming of the transmitter.

Proper function of the RC system is dependent upon several factors that are not controllable by the manufacturer. RGC is not responsible for the following: Improper installation, Low battery, Natural occurrences, Use other than intended, Location of panel, receiver or transmitter too close to interfering metal objects, Multiple RC panels within 15 feet of each other, Use in area with external interference such as radio, cell phone, and TV towers or a natural magnetic field, Blocked or shielded antenna, Other transmitter interference from cell phones, cordless phones, wireless systems, CB and mobile transmitters, computer and industrial equipment, electric motors, even fluorescent lights.

Lock/ Unlock remote unit

To unlock or lock your remote units, press the two blue buttons simultaneously on your remote. The display will indicate locked or unlocked mode.

Reprogramming Your Remote Control

In the event that you may need to reprogram your remote control unit, please follow these step instructions:

1. Hold down both the red button (located on the black RC box) and the “UP” button (located on the hand held remote) at the same time for five (5) seconds.

Note: If black box does not have red button on the outside use the next procedure below.

2. Release “RED” button (located on the black RC box) and continue to hold down the “UP” button (located on the hand held remote) for an additional five (5) seconds.

-OR-

1. Remove cover from black RC box. A see-through cover control unit is inside this box. Hold down “black” button (located on the side of the see-through control unit) until red light flashes once in the see-through control unit located in corner.
2. Release the “black” button then hold down the “UP” button (located on the hand held remote) for five (5) seconds.

You may have to repeat these two (2) steps more than once to reset your remote control unit.

5.6 STORAGE PROCEDURE

1. Position boat on platform so the lower unit of the motor is against the optional motor stop (if used).
2. A boat that has water in it from a rain storm could exceed the recommended weight capacity for the lift. Just 1 gallon of water weighs over 8 pounds. Be sure to remove the plug while the boat is up on the lift. Make sure you replace the plug prior to launching your boat.
3. Protect your lift as far as possible from damage caused by environmental factors such as airborne fallout, chemicals, tree sap, and weather hazards.
4. Never use the lift to hang or store any auxiliary equipment such as boating hardware.
5. Do not allow anyone to swim or play near the lift at any time.



CAUTION:

DO NOT STORE THE LIFT IN THE WATERWAY IF FREEZING TEMPERATURES ARE EXPECTED. THIS WILL CAUSE EQUIPMENT DAMAGE.

6. Disconnect and store battery to prevent from freezing.
7. Disconnect and store hydraulic cylinders, hydraulic hoses, and control box in a warm dry area if temperatures or wind chill factors below minus 20 degrees F are expected.

5.7 HYDRAULIC SYSTEM FLUSH

It is recommended that as part of an annual maintenance program, the hydraulic system be drained and fresh aqua-marine Grade hydraulic oil installed. RGC recommends CITGO Aqua Marine Hydraulic 46H (or equivalent biodegradable oil) be used.

1. Lower the platform until the cylinder are fully retracted.



WARNING:

FOLLOW THE SAME SAFETY RULES WHEN WORKING INSIDE THE CONTROL BOX AND AROUND THE BATTERY THAT APPLY TO ANY CAR OR BOAT BATTERY. A BATTERY CAN EXPLODE AND CAUSE PERSONAL INJURY AND/OR EQUIPMENT DAMAGE.

2. Disconnect couplings between cylinder hoses and control box.
3. Unscrew reservoir oil fill cap.
4. Siphon old oil from reservoir using a hand siphon or vacuum pump. If not available, remove the 12-volt battery from control box, and very carefully tip over the control box to drain oil from reservoir into a bucket.

5. Remove reservoir from pump assembly to inspect oil filter screen. Be careful not to damage O-ring seal for reservoir. If necessary, clean the filter screen with soap and water.
6. Reassemble reservoir and pump assembly, then fill reservoir with fresh CITGO Aqua Marine Hydraulic 46.



WARNING:

LIQUID UNDER HIGH PRESSURE CAN PIERCE THE SKIN, CAUSING DEATH OR SERIOUS INJURY. IN CASE OF INJURY, GET IMMEDIATE MEDICAL ATTENTION.

7. Depressurize cylinder hoses as follows:
 - a. Depressurize the cylinder hose with male coupling by wrapping a rag around the coupling (to prevent spray) and carefully pressing the end button against a hard flat surface. Use caution to avoid damaging the coupling button.
 - b. Depressurize the cylinder hose with female coupling by wrapping a rag around coupling (to prevent spray) and carefully press the internal button using a 3/8" bolt. Be very careful not to damage the internal O-rings. Be sure that both couplings are kept clean at all times.
9. Clean the lower cylinder hose coupling and reconnect to the control box.
10. Connect a spare coupling or remove quick-disconnect from the upper cylinder hose assembly.
11. While holding open hose end over a suitable container, press the UP button until cylinders are fully extended.
12. Reverse the hoses so that the spare fittings are on lower cylinder hose.
13. Be sure to keep reservoir filled with new oil.
14. While holding open hose end over a suitable container, press the DOWN button until cylinders are fully retracted.
15. Repeat steps 10 to 13 until oil coming from disconnected hose is clean. Then reconnect hose couplings to control box.
16. As these procedures are performed, additional oil may need to be added to the reservoir. Perform a final check of oil level with cylinders fully retracted.

6 TROUBLESHOOTING

The following chart is intended to assist with troubleshooting your vertical lift. While not all inclusive, the chart outlines the most common causes of a problem and the recommended course of action.



CAUTION:

IF THE PROBLEM WITH THE POWER SUPPLY IS NOT CERTAIN, ALWAYS FOLLOW THE MANUFACTURER’S WARRANTY POLICY BEFORE ANY OTHER REPAIR OR MAINTENANCE IS ATTEMPTED.

SYMPTOM	CAUSE AND CORRECTIVE ACTION
Hoses cannot be connected.	<p>System is pressurized. Depressurize the hoses as follows:</p> <ul style="list-style-type: none"> a. Depressurize the male fitting by carefully pressing the button on the end of the nipple or by briefly tapping the down switch. Use caution to avoid damaging the nipple button. b. Depressurize the female fitting by tapping the “up” switch briefly, which will depressurize the pump. If necessary, depressurize the female fitting on the hose by carefully pressing the internal button using a 3/8” bolt. Be careful not to damage the internal O-rings. Wrap the fitting with a rag while depressurizing to prevent spray. Keep the connectors clean.
Battery does not keep a charge.	<p>Check the battery fluid levels, age, and time of last booster charge. The battery must be booster charged at the beginning and end of the season using a 10A charger.</p> <p>Verify solar panel or a/c charger is plugged in correctly.</p> <p>Check the voltage output of the solar panel. Output should be about 14-18 volts when exposed to light.</p> <p>Verify that the polarity (positive or negative) of the solar panel matches the battery’s polarity.</p> <p>Verify that the solar panel gets an adequate amount of light and the lift usage is within the monthly seasonal limits. The solar panel may be mounted up to 50 feet away from the battery if necessary. You may also order a bracket to mount the solar panel on top of the canopy. The remote control should only be drawing about 5 mA, and the pump 20 mA. The solar panel has an output of about 750 mA in direct sunshine.</p>
Battery terminal becomes hot.	Verify cable is clean and tight on battery terminal
Remote control not functioning.	The remote control is designed to stop working if the battery drops below 10 volts to alert the user that the battery is getting low. If the lift operates with the up/down switch in the power supply, but not with the remote, charge the battery using a 10A booster charger.

SYMPTOM	CAUSE AND CORRECTIVE ACTION
Lift is operating properly, but platform raising is either difficult or impossible.	<p>Platform is binding because frame is either not square or not set level in the water—refer to Sections 3.6 and 3.7.</p> <p>One or more wires are broken—refer to Section 5. 2</p> <p>Sheaves binding—inspect/lubricate/replace.</p> <p>One or more cables are excessively worn—replace as required and follow monthly wire rope inspection procedure described in Section 5.2.</p> <p>Load exceeds rated capacity— Reduce load weight as needed.</p> <p>User or dealer installed locking devices are in place—remove these.</p> <p>Auxiliary equipment such as boating hardware is being improperly hung on lift—remove this equipment permanently.</p>
Boat is not lifting level—stern is lifting higher or lower than the bow.	<p>Frame is not level in the water—relocate pin connections between the adjustable and vertical legs.</p> <p>Frame is level in the water but spreader tube cables are not tight enough—</p> <ol style="list-style-type: none"> 1. Tighten down the cable stud nut to add tension to the B-C spreader tube cable. 2. Tighten down the cable stud nut to add tension to the A-D spreader tube cable. Check that the B-C and A-D spreader tube cables are equal in tension and that the platform is level.
Boat shifts position when operating the lift.	Boat is not properly secured on the lift—failure to properly secure boat can cause equipment damage and/or serious personal injury.
Lowest platform position is too high or low relative to the water.	Connections between the vertical and adjustable legs need readjusting—do this with the Item C leg pin shown in Figure 3-3.
Boat is getting damaged during raising or lowering operations.	One or more bolts are installed improperly--all bolts except those on the bottom parts of the braces must be installed from the inside of the lift.
Remote control range is limited.	Check battery in key chain transmitter. If the range is only limited while in your boat, try holding the transmitter over your head. Proximity to cell phone towers, power lines, and other electromagnetic interference can also reduce remote control range.

SYMPTOM	CAUSE AND CORRECTIVE ACTION
Fluid overflows reservoir.	It is normal to see some fluid overflow from the reservoir when the platform is cycled all the way down the first few times.
Lift stops after a split second.	Battery is low. If the battery is becoming low, the remote control will stop functioning at about 11 volts. The lift can still be operated using the up/down switch in the power supply, but the pump motor will stop and the green solenoid light will shut off if the voltage drops below 9 volts. Charge the battery using a 10A charger.
Power supply is operating properly, but platform raising is either difficult or impossible.	<p>Platform is binding because frame is either not square or not set level in the water—refer to Section 3.10.</p> <p>Load exceeds rated capacity— reduce load weight as needed.</p> <p>User or dealer installed locking devices are in place—remove these.</p> <p>Auxiliary equipment such as boating hardware is being improperly hung on lift—remove this equipment permanently.</p> <p>Hoses to cylinders are leaking fluid in line, have a poor connection, or are kinked.</p> <p>Hydraulic system malfunctioning—contact your authorized service center.</p>
Cylinders fail to hold the platform in a given position as described in the test procedure of Section 4.2	<p>Check hose connections.</p> <p>Contact your authorized dealer—tampering with the hydraulic system can cause equipment damage that may invalidate your warranty.</p>
Lift does not go down.	<p>Turn the speed control knob counter clockwise. This valve only limits the downward speed of the lift. If that does not solve the problem, check that the black wire is connected to the left coil on the pump, and the yellow wire is on the right coil.</p> <p>Sheaves binding—inspect/lubricate/replace.</p>
Lowest platform position is too high or low relative to the water.	Connections between the vertical and adjustable legs need readjusting as described in Chapter 3.
Boat is not lifting level—stern is lifting higher or lower than the bow.	Frame is not level in the water—relocate pin connections between the adjustable and vertical legs.
Boat shifts position when operating the lift.	Boat is not properly secured on the lift—failure to properly secure boat can cause equipment damage and/or serious personal injury.

7 PARTS LISTS

Each reference number or letter in the following parts lists can be matched with the reference number or letter referred to in both the text and illustrations of Chapter 3, Installation and Setup.

7.1 #3641--- HVL 70124 TALL CONVERSION KIT BUNDLE

7.2.1 #3641--- HVL 70124 TALL Bundle 1 of 1

REF #	PART #	QTY	DESCRIPTION
4	3641472	1	HVL VERTICAL LEG (B) ASSY 5K TALL
15	3641347	1	HVL CYLINDER & HOSE ASSY 7K TALL, See Section 7.7
	3641---	1	HVL / HARDWARE CARTON 7K See Section 7.3
	3641340	1	HVL POWER UNIT-STANARD, See Section 7.4

7.3 #3641--- HVL CONVERSION KIT HARDWARE CARTON 7K

REF #	PART #	QTY	DESCRIPTION
	3641---	1	HVL CONVERSION KIT BAG OF BOLTS consisting of:
A	5896257	2	3/8-16 X 3-1/2 HHCS
B	5896406	2	3/8 WASHER SAE
C	5806243	2	3/8 WASHER SPLIT LOCK
D	5896377	2	3/8-16 NUT HEX
P	5896248	12	3/8-16 X 1-1/4" HHCS
J	5896247	3	3/8-16 X 1" HHCS
M	5897016	15	3/8-16 LOCKNUT NYLOCK
AA	5896309	2	5/8-11 X 2" HHCS
AB	5896414	2	5/8 WASHER SAE
AC	5806246	2	5/8 WASHER SPLIT LOCK
AD	5896380	2	5/8-11 NUT HEX
AH	5800867	8	HOSE CLAMP
Q	5893642	4	3/4-16 HEX NUT
17	3641412	1	HVL7K ANCHOR WELDMENT LH
18	3641414	1	HVL7K ANCHOR WELDMENT RH
R	3641620	2	HVL CAP PLASTIC 2 X 4 X 1/8W -HOLE
16	3641615	2	NYLON SPACER 2 OD X 1-3/16 LG

7.4 HVL POWER UNIT

REF #	PART #	QTY	DESCRIPTION
19	3641340	1	HVL CONTROL BOX 12V (STANDARD)
	4110020	1	HL SOLAR PANEL KIT (OPTIONAL)
	4105785	1	HL AC CHARGER (OPTIONAL)
	4107431	1	HL LIGHTING PACKAGE (OPTIONAL)

7.5 3641-- HVL POWER UNIT SHELF & HARDWARE (OPTIONAL)

REF #	PART #	QTY	DESCRIPTION
20	3641415	1	HVL SHELF FRAME
21	3641532	1	HVL SHELF DIAG. BRACE 7K TALL
22	4100583	1	HVL SHELF BRACKET
	3641225	1	HVL SHELF BAG OF BOLTS consists of following:
AE	5896248	4	3/8-16 X 1-1/4" HHCS
AF	5897016	8	3/8-16 LOCKNUT NYLOCK
AG	5896247	4	3/8-16 x 1" HHCS

#3641347 HVL 7KT HYDRAULIC CYLINDER ASSEMBLY – See Figure 7.1

REF #	PART #	QTY	DESCRIPTION
1	6036416	1	Hydraulic Cylinder 3-1/2" bore x 36" stroke
2	3641970	1	Cylinder Stop Tube
3	3607787	1	Bushing Sleeve 1" OD x 1.47" lg
4	3709050	1	CW R18 Spacer
5	6041010	1	Flow Regulator
6	5896417	1	3/4" SAE Washer
7	5806265	1	3/4" Lockwasher
8	5896381	1	3/4-10 Hex Nut
9	5896267	6	3/8-16 x 6" lg HHCS
10	6236412	1	Decal "CAUTION NOT A STEP"
11	3641767	1	Cylinder Clevis pin 1" DIA x 4-1/8" lg
12	5897016	6	3/8-16 Hex Locknut
13	7336830	1	Sheave 3-3/8 Sgl
14	3641354	1	Mounting Bracket (D) powder coat
15	5636414	1	3/8" tube 37-degree to SAE -12 straight fitting
16	3641777	1	Cylinder Rod Clevis
17	3641772	2	Cylinder Clevis Pin 1-1/2" DIA x 5" lg
18	5893645	8	1/8" x 2" Cotter Pin
19	7341950	2	Sheave 4-3/4 Sgl 1-1/2" bore
20	3641560	2	Cover Channel 107-1/8"
21	3641352	1	Mounting bracket (A) powder coat
22	3641575	2	HVL7K cover plate- common
23	3641565	1	HVL7K cover plate- cylinder end
24	3641570	1	HVL7K cover plate- cable end
25	3641910	1	HL Clevis Pin 7/8" DIA X 4-3/8"
26	5896121	1	3/4-10 x 3-1/2" lg HHCS
27	7341955	2	Sheave 5-1/4 Sgl- 1-1/2" bore
28	3641932	1	HVL Cable assembly SS 3/8" X 231
29	3641927	1	HVL Cable assembly SS 3/8" X 125
30	3641955	1	Hydraulic Hose Assy 31' x 1/4" (straight)
31	3641960	1	Hydraulic Hose Assy 29' x 1/4" (90-degree)
32	5806348	2	5/16-18 x 5/16 lg set screw
33	3641925	1	HVL7K Cylinder guide plate
34	5892801	4	1/4-20 x 1" Phillip Flat Head Screw
35	5636412	1	3/8 tube 37-degree to 1/4 pipe 90-degree fitting
36	5636411	1	1/4 pipe to 1/4 tube 37-degree straight fitting
37	5636413	1	1/4 tube 37-degree to SAE-12 straight fitting
38	6000700	1	Coupling 1/4 NPT female
39	6000701	1	Coupling 1/4 NPT male
40	5893641	24	10-24 X 3/8 Phil Pan Head- Self Thread
41	3641732	1	HVL Support Tube Spacer

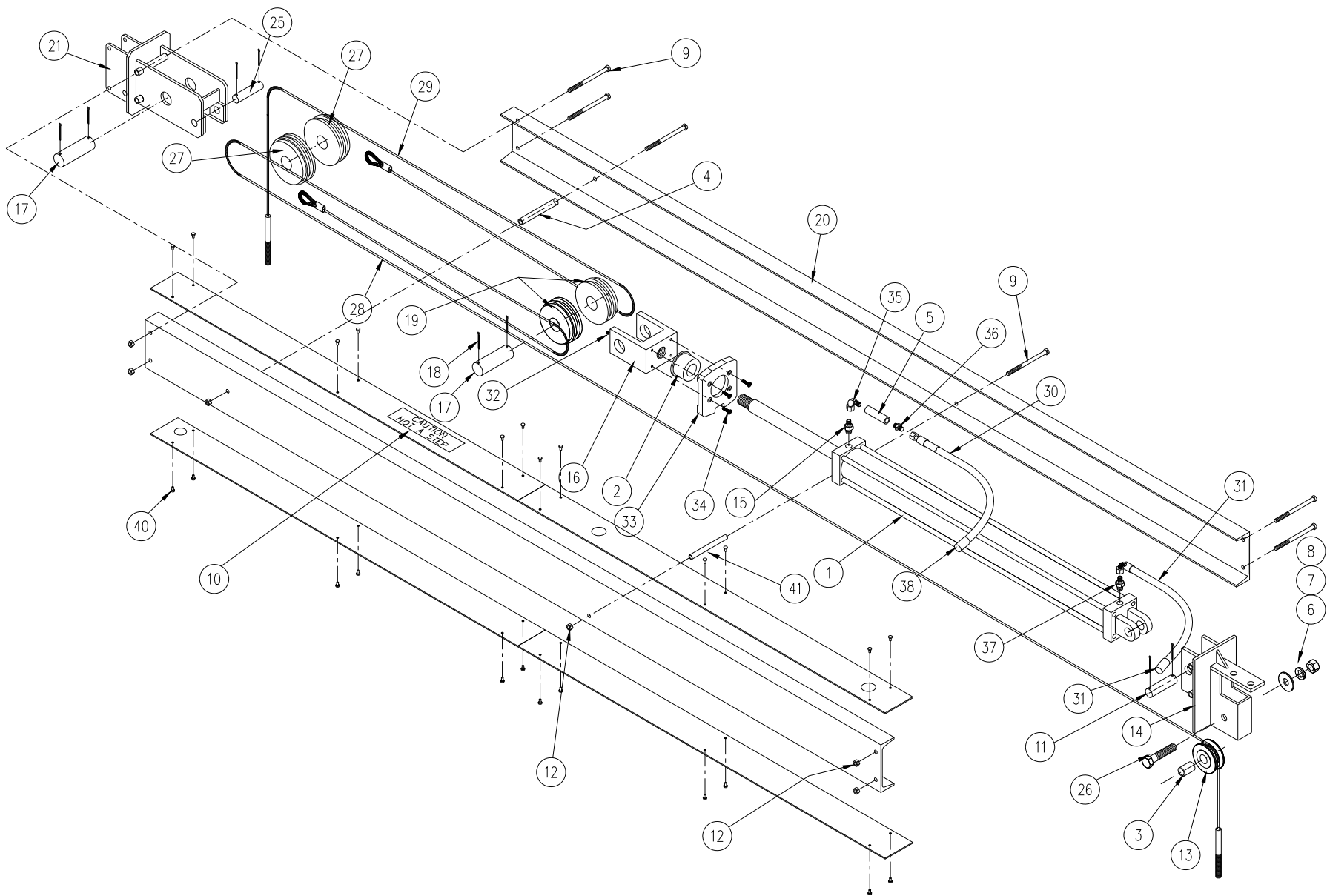
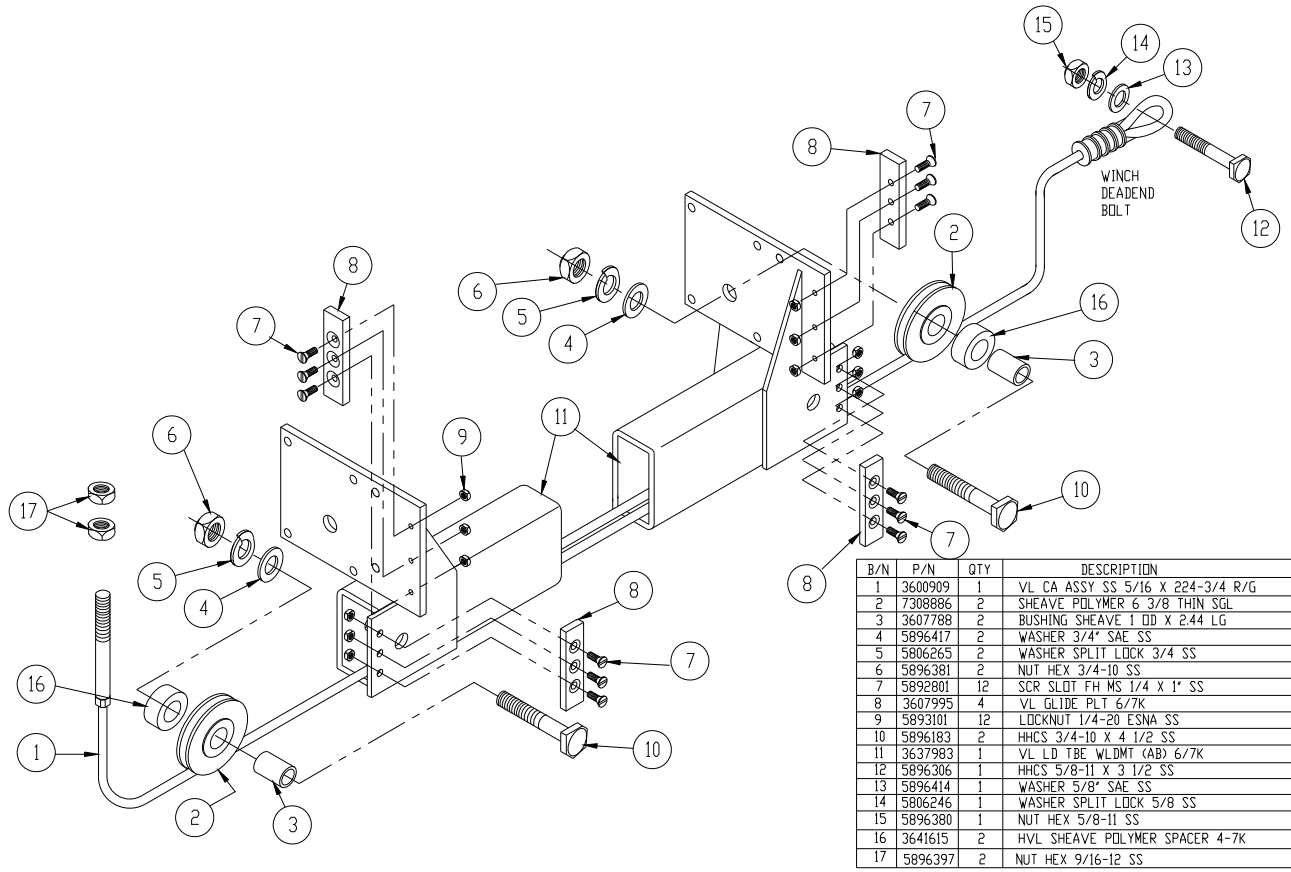

Figure 7-1
Hydraulic Cylinder Assembly- exploded vie

P/N 3641362 - HVL 70124T (AB) LOAD TUBE PARTS LIST



B/N	P/N	QTY	DESCRIPTION
1	3600909	1	VL CA ASSY SS 5/16 X 224-3/4 R/G
2	7308886	2	SHEAVE POLYMER 6 3/8 THIN SGL
3	3607788	2	BUSHING SHEAVE 1 DD X 2.44 LG
4	5896417	2	WASHER 3/4" SAE SS
5	5806265	2	WASHER SPLIT LOCK 3/4 SS
6	5896381	2	NUT HEX 3/4-10 SS
7	5892801	12	SCR SLOT FH MS 1/4 X 1" SS
8	3607995	4	VL GLIDE PLT 6/7K
9	5893101	12	LOCKNUT 1/4-20 ESNA SS
10	5896183	2	HHCS 3/4-10 X 4 1/2 SS
11	3637983	1	VL LD TBE WLDMT (AB) 6/7K
12	5896306	1	HHCS 5/8-11 X 3 1/2 SS
13	5896414	1	WASHER 5/8" SAE SS
14	5806246	1	WASHER SPLIT LOCK 5/8 SS
15	5896380	1	NUT HEX 5/8-11 SS
16	3641615	2	HVL SHEAVE POLYMER SPACER 4-7K
17	5896397	2	NUT HEX 9/16-12 SS

P/N 3641364 - HVL 70124T (CD) LOAD TUBE PARTS LIST

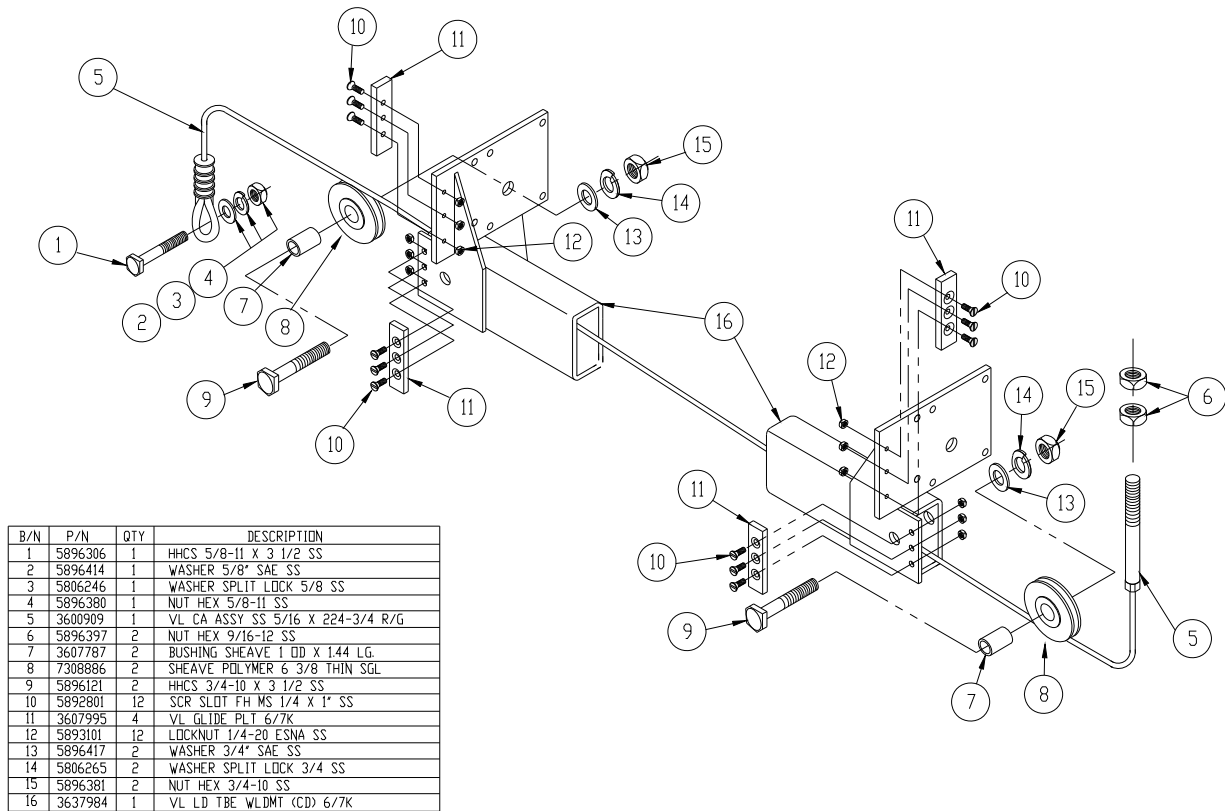

B/N	P/N	QTY	DESCRIPTION
1	5896306	1	HHCS 5/8-11 X 3 1/2 SS
2	5896414	1	WASHER 5/8" SAE SS
3	5806246	1	WASHER SPLIT LOCK 5/8 SS
4	5896380	1	NUT HEX 5/8-11 SS
5	3600909	1	VL CA ASSY SS 5/16 X 224-3/4 R/G
6	5896397	2	NUT HEX 9/16-12 SS
7	3607788	2	BUSHING SHEAVE 1 DD X 1.44 LG
8	7308886	2	SHEAVE POLYMER 6 3/8 THIN SGL
9	5896121	2	HHCS 3/4-10 X 3 1/2 SS
10	5892801	12	SCR SLOT FH MS 1/4 X 1" SS
11	3607995	4	VL GLIDE PLT 6/7K
12	5893101	12	LOCKNUT 1/4-20 ESNA SS
13	5896417	2	WASHER 3/4" SAE SS
14	5806265	2	WASHER SPLIT LOCK 3/4 SS
15	5896381	2	NUT HEX 3/4-10 SS
16	3637984	1	VL LD TBE WLDMT (CD) 6/7K

LIMITED PRODUCT WARRANTY

Reimann & Georger Corporation Marine Products

RGC Marine products, hereafter referred to as the “Manufacturer”, extends this limited warranty to the original purchaser of this product. The original purchaser, hereinafter referred to as the “Buyer”, is defined as the first legal owner of this product other than an authorized distributor or dealer who has bought the product from the Manufacturer for resale to the public. **The Buyer must complete and return the Warranty Registration section of the provided Warranty Card to make this limited warranty effective.**

CONSUMER PRODUCT PROVISIONS

I. ARTICLE I—CONSUMER PRODUCT PROVISIONS: THE FOLLOWING PROVISIONS SHALL BE APPLICABLE IF THIS PRODUCT IS BEING PURCHASED FOR PERSONAL, FAMILY OR HOUSEHOLD PURPOSES.

THE CONSUMER PRODUCT PROVISIONS CONTAINED IN THIS ARTICLE I SHALL APPLY UNLESS THIS PRODUCT IS BEING PURCHASED SOLELY FOR COMMERCIAL OR INDUSTRIAL USE, IN WHICH EVENT THE PROVISIONS CONTAINED IN ARTICLE II BELOW SHALL APPLY AND THE PROVISIONS CONTAINED IN THIS ARTICLE I SHALL BE INAPPLICABLE.

A. 2-YEAR LIMITED WARRANTY

The Manufacturer warrants to the Buyer that all supplied parts shall be free of defects in material and workmanship for a period of two (2) years from date of original purchase. This limited warranty covers the cost of all parts and labor needed to repair any item that is found to be defective in material and workmanship. Items covered include cables, sheaves, chains, motors, reducers, switches, control panels and ground fault circuit interrupters.

B. 15-YEAR LIMITED WARRANTY ON VL/PL SERIES ALUMINUM FRAME EXTRUSION

The Manufacturer warrants to the Buyer that the frame and extrusions shall be free of defects in material and workmanship for a period of fifteen (15) years from date of original purchase. This limited warranty covers the cost of all parts and labor needed to repair any item that is found to be defective in material and workmanship.

C. MANUFACTURER’S OBLIGATIONS

The Manufacturer’s sole obligation under either of these limited warranties is the replacement or repair, at the Manufacturer’s discretion, of parts found to be defective.

D. NO SPECIAL, INCIDENTAL OR CONSEQUENTIAL DAMAGES

IN NO EVENT SHALL THE MANUFACTURER BE LIABLE TO THE BUYER OR ANY PERSON FOR ANY INDIRECT, SPECIAL, INCIDENTAL, OR CONSEQUENTIAL LOSSES OR DAMAGES CONNECTED WITH THE USE OF THE PRODUCT UNDER WARRANTY. SUCH DAMAGES FOR WHICH THE MANUFACTURER SHALL NOT BE RESPONSIBLE INCLUDE, BUT ARE NOT LIMITED TO, LOST TIME AND CONVENIENCE, LOSS OF USE OF THE PRODUCT, THE COST OF A PRODUCT RENTAL, COSTS OF GASOLINE, TELEPHONE, TRAVEL, OR LODGING, THE LOSS OF PERSONAL OR COMMERCIAL PROPERTY, AND THE LOSS OF REVENUE.

Some States do not allow the exclusion or limitation of incidental or consequential damages, so the above limitation or exclusion may not apply to you.

E. NO LIABILITY IN EXCESS OF PURCHASE PRICE

IN NO EVENT SHALL THE MANUFACTURER'S OBLIGATIONS UNDER THIS LIMITED WARRANTY EXCEED THE PURCHASE PRICE OF THE PRODUCT.

F. NO EXTENSION OF STATUTE OF LIMITATIONS

ANY REPAIRS PERFORMED UNDER EITHER OF THESE WARRANTIES SHALL NOT IN ANY WAY EXTEND THE TWO-YEAR AND FIFTEEN-YEAR STATUTES OF LIMITATIONS CONTAINED IN THIS LIMITED WARRANTY.

G. PROCEDURE FOR WARRANTY PERFORMANCE

If the product fails to perform to the Manufacturer's specifications, the Buyer must contact the dealer from whom the product was purchased. The Buyer must provide the dealer with the applicable model and serial numbers, the date of purchase, and the nature of the problem.

H. PREAPPROVAL OF LABOR COSTS

All labor costs related to a dealer's performance of the warranty obligations under this limited warranty must be pre-approved by Reimann & Georger Corp. Marine Products.

I. NO OTHER EXPRESS WARRANTIES

THE MANUFACTURER IS NOT SUBJECT TO ANY EXPRESS WARRANTIES OTHER THAN THOSE SET FORTH ABOVE.

J. LIMIT ON DURATION OF IMPLIED WARRANTIES

THE DURATION OF ANY IMPLIED WARRANTIES UNDER APPLICABLE STATE LAW RELATING TO THE PURCHASE OF THIS PRODUCT SHALL BE LIMITED TO A PERIOD OF TWO (2) YEARS FROM THE DATE OF PURCHASE.

Some States do not allow limitations on how long an implied warranty lasts, so the above limitations may not apply to you.

K. QUESTIONS REGARDING LIMITED WARRANTY

Any questions regarding this limited warranty or the procedure which the consumer should follow in order to obtain performance of any warranty obligation may be addressed to either the dealer from whom this product is purchased or to Reimann & Georger Corp. Marine Products, P.O. Box 681, Buffalo, NY 14240.

L. EXCLUSIONS FROM LIMITED WARRANTY. THIS LIMITED WARRANTY DOES NOT COVER ANY OF THE FOLLOWING:

1. Equipment which has been abused, damaged, used beyond rated capacity, or which is damaged or has defects caused by repairs or service completed by persons other than authorized service personnel.
2. Costs of repairing damage caused by environmental factors which include, but are not limited to, airborne fallout, chemicals, tree sap, salt, ocean spray, and water hazards.
3. Damage caused by acts of God which include, but are not limited to, hailstorms, windstorms, tornadoes, sandstorms, lightning, floods, and earthquakes.

4. Damage under conditions caused by fire or accident, by abuse or negligence, by improper installation, by misuse, by incorrect operation, by “normal wear and tear”, by improper adjustment or alteration, by alterations not done by the Manufacturer, or by failure of product parts from such alterations.
5. Costs of repairing damage caused by poor or improper maintenance, costs of normally scheduled maintenance, or the cost of replacing any parts unless done as the result of a repair covered by your two-year limited warranty.
6. Costs of modifying the product in any way once delivered to the Buyer, even if such modifications were added as a production change on other products made after the Buyer’s product was built.

M. RIGHT TO MODIFY PRODUCT

The Manufacturer has the right to modify this product at any time without incurring any obligation to make the same or similar modifications on products previously purchased.

N. NO AUTHORITY TO ALTER WARRANTY

No agent, representative, distributor or dealer has any authority to alter the terms of this warranty in any way.

O. SPECIFIC LEGAL RIGHTS

This warranty gives you specific legal rights and you may also have other rights which vary from State to State.

COMMERCIAL PRODUCT PROVISIONS

II. ARTICLE II—COMMERCIAL PRODUCT PROVISIONS: THE FOLLOWING PROVISIONS SHALL BE APPLICABLE ONLY IF THIS PRODUCT IS BEING PURCHASED SOLELY FOR COMMERCIAL OR INDUSTRIAL USE. IF THIS PRODUCT IS BEING PURCHASED FOR PERSONAL, FAMILY OR HOUSEHOLD PURPOSES, THE PROVISIONS CONTAINED IN THIS ARTICLE II SHALL NOT BE APPLICABLE AND THE PROVISIONS CONTAINED IN ARTICLE I ABOVE SHALL APPLY.

A. 1-YEAR LIMITED WARRANTY

The Manufacturer warrants to the Buyer that all supplied parts shall be free of defects in material and workmanship for a period of one (1) year from date of original purchase. This limited warranty covers the cost of all parts and labor needed to repair any item that is found to be defective in material and workmanship. Items covered include cables, sheaves, chains, motors, reducers, switches, control panels and ground fault circuit interrupters.

B. 5-YEAR LIMITED WARRANTY ON VL/PL SERIES ALUMINUM FRAME EXTRUSION

The Manufacturer warrants to the Buyer that the frame and extrusions shall be free of defects in material and workmanship for a period of five (5) years from date of original purchase. This limited warranty covers the cost of all parts and labor needed to repair any item that is found to be defective in material and workmanship.

C. MANUFACTURER'S OBLIGATIONS

The Manufacturer's sole obligation under either of these limited warranties is the replacement or repair, at the Manufacturer's discretion, of parts found to be defective.

D. NO SPECIAL, INCIDENTAL, OR CONSEQUENTIAL DAMAGES

IN NO EVENT SHALL THE MANUFACTURER BE LIABLE TO THE BUYER OR ANY PERSON FOR ANY INDIRECT, SPECIAL, INCIDENTAL, OR CONSEQUENTIAL LOSSES OR DAMAGES CONNECTED WITH THE USE OF THE PRODUCT UNDER WARRANTY. SUCH DAMAGES FOR WHICH THE MANUFACTURER SHALL NOT BE RESPONSIBLE INCLUDE, BUT ARE NOT LIMITED TO, LOST TIME AND CONVENIENCE, LOSS OF USE OF THE PRODUCT, THE COST OF A PRODUCT RENTAL, COSTS OF GASOLINE, TELEPHONE, TRAVEL, OR LODGING, THE LOSS OF PERSONAL OR COMMERCIAL PROPERTY, AND THE LOSS OF REVENUE.

E. NO LIABILITY IN EXCESS OF PURCHASE PRICE

IN NO EVENT SHALL THE MANUFACTURER'S OBLIGATIONS UNDER THIS LIMITED WARRANTY EXCEED THE PURCHASE PRICE OF THE PRODUCT.

F. NO EXTENSION OF STATUTE OF LIMITATIONS

ANY REPAIRS PERFORMED UNDER EITHER OF THESE WARRANTIES SHALL NOT IN ANY WAY EXTEND THE RESPECTIVE STATUTES OF LIMITATIONS CONTAINED IN THIS LIMITED WARRANTY.

G. WAIVER OF OTHER WARRANTIES

THESE EXPRESS WARRANTIES ARE IN LIEU OF AND EXCLUDE ANY AND ALL OTHER WARRANTIES, EXPRESS OR IMPLIED, INCLUDING, BUT NOT LIMITED TO, THE IMPLIED WARRANTIES OR MERCHANTABILITY AND FITNESS FOR A PARTICULAR PURPOSE.

H. PROCEDURE FOR WARRANTY PERFORMANCE

If the product fails to perform to the Manufacturer's specifications, the Buyer must contact the dealer from whom the product was purchased. The Buyer must provide the dealer with the applicable model and serial numbers, the date of purchase, and the nature of the problem.

I. PREAPPROVAL OF LABOR COSTS

All labor costs related to a dealer's performance of the warranty obligations under this limited warranty must be pre-approved by Reimann & Georger Corp. Marine Products.

J. EXCLUSIONS FROM WARRANTY. THIS LIMITED WARRANTY DOES NOT COVER ANY OF THE FOLLOWING:

1. Equipment which has been abused, damaged, used beyond rated capacity, or which is damaged or has defects caused by repairs or service completed by persons other than authorized service personnel.
2. Costs of repairing damage caused by environmental factors which include, but are not limited to, airborne fallout, chemicals, tree sap, salt, ocean spray, and water hazards.
3. Damage caused by acts of God which include, but are not limited to, hailstorms, windstorms, tornadoes, sandstorms, lightning, floods, and earthquakes.
4. Damage under conditions caused by fire or accident, by abuse or negligence, by improper installation, by misuse, by incorrect operation, by "normal wear and tear", by improper adjustment or alteration, by alterations not done by the Manufacturer, or by failure of product parts from such alterations.
5. Costs of repairing damage caused by poor or improper maintenance, costs of normally scheduled maintenance, or the cost of replacing any parts unless done as the result of a repair covered by your one-year limited warranty.
6. Costs of modifying the product in any way once delivered to the Buyer, even if such modifications were added as a production change on other products made after the Buyer's product was built.

K. RIGHT TO MODIFY PRODUCT

The Manufacturer has the right to modify this product at any time without incurring any obligation to make the same or similar modifications on products previously purchased.

L. NO AUTHORITY TO ALTER WARRANTY

No agent, representative, distributor, or dealer has any authority to alter the terms of this warranty in any way.

M. SPECIFIC LEGAL RIGHTS

This warranty gives you specific legal rights, and you may also have other rights which vary from State to State.