



GUIDE-ON ROLLER ASSEMBLY

Your Reimann & Georger Corporation Marine Products Aluminum Guide-On Roller Assembly is designed to aid in the positioning of boat on lift. Your Roller Assembly is well-designed and well-built. However, like any other equipment, it can malfunction or become hazardous in the hands of an inexperienced and/or untrained user. Therefore, read this entire manual, your related Guide-On manual, and related equipment manuals thoroughly before installing this kit and operating your lift to provide maximum safety for all operating personnel, and to get the maximum benefit from your equipment.

1 SAFETY

A safety message alerts you to potential hazards that could hurt you or others or cause property damage. The safety messages or signal words for product safety signs are **DANGER**, **WARNING**, and **CAUTION**. Each safety message is preceded by a safety alert symbol and is defined as follows:

DANGER: Indicates an imminently hazardous situation which, if not avoided, **will** cause death or serious injury. This safety message is limited to the most extreme situations.

WARNING: Indicates a potentially hazardous situation which, if not avoided, **could** result in death or serious injury.

CAUTION: Indicates a potentially hazardous situation which, if not avoided, **may** result in minor or moderate injury. It may also be used to alert against unsafe practices and property-damage-only accidents.

2 INSTALLATION AND SET UP

2.1 PRE-INSTALLATION CHECKS

1. Do not assemble this kit or any other component of the lift if any part appears to be damaged.
2. Do not weld or other wise modify any portion of the lift. Such alterations may weaken the structural integrity of the lift and void the warranty.

2.2 PRIOR TO SETUP

The part reference letters used in the parts list are the same as those shown in Figure 3-1.

2.3 GUIDE-ON ASSEMBLY

(Refer to Figure 3-1) Insert the guide-on roller bracket, with the stop tab facing up, into the same channel section of the aluminum guide-on as the guide-on upper tube assembly, until the stop tab touches the guide-on. Secure roller bracket using two each, flat washer (J), and hex head cap screw (K). Thread screw into bracket until it gently contacts the guide-on. Do not over tighten screws. Repeat for other roller assembly.

CAUTION : DO NOT OVER TIGHTEN SCREWS. TO DO SO WILL DAMMAGE THE TOP SURFACE OF THE ALUMINUM GUIDE-ON.

3 VL GUIDE-ON PARTS LIST

3.1 3601065 Guide-On Roller Carton of Parts (Aluminum Guide-On Only)

| PART # | QTY | DESCRIPTION |
|---------|-----|-----------------------------|
| 3601070 | 1 | GUIDE-ON ROLLER ASSEMBLY LH |
| 3601075 | 1 | GUIDE-ON ROLLER ASSEMBLY RH |
| 5896249 | 4 | 3/8-16 X 1-1/2" HHCS |

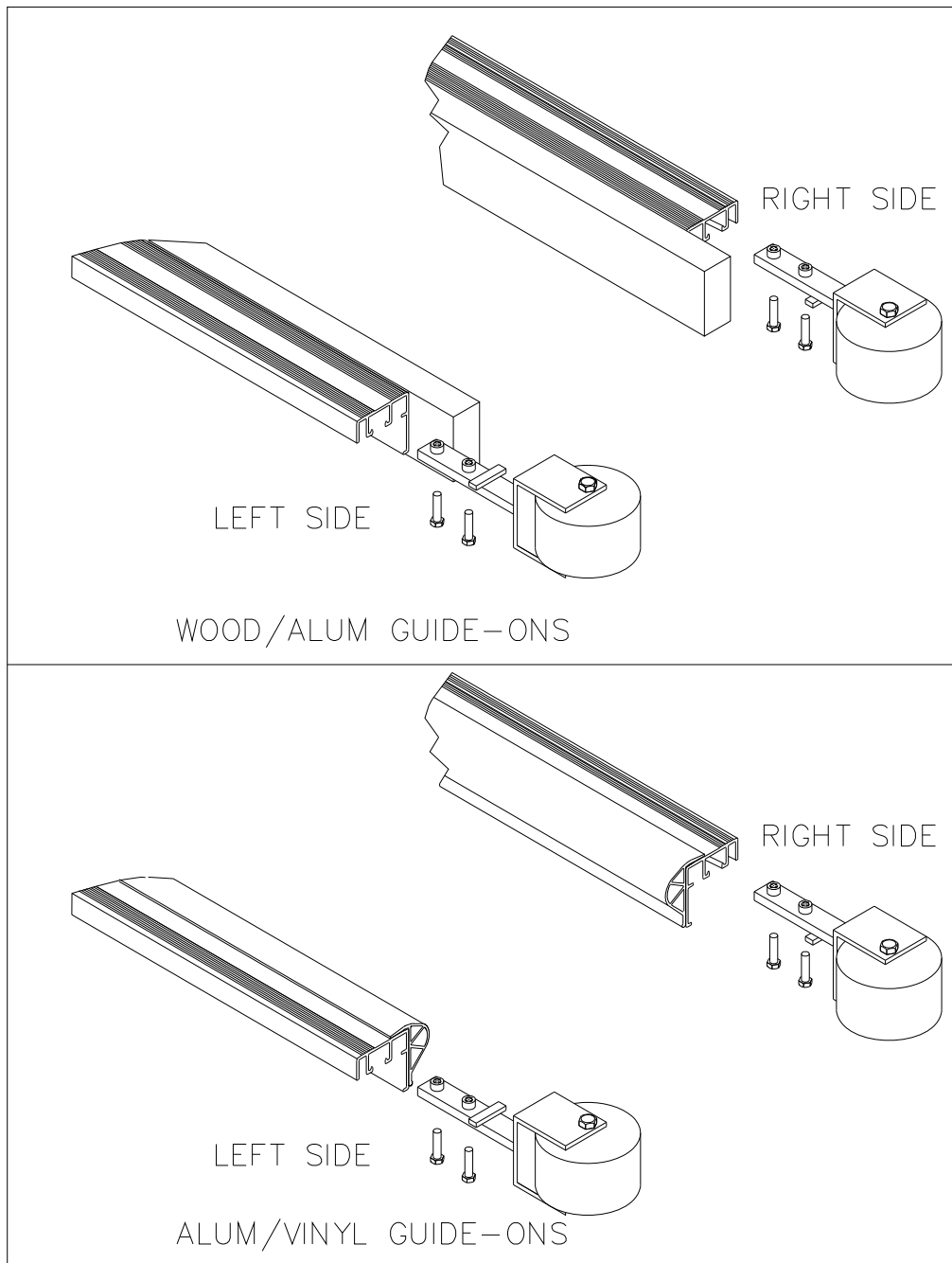

(Figure 3-1)
Guide-On Roller Assembly