

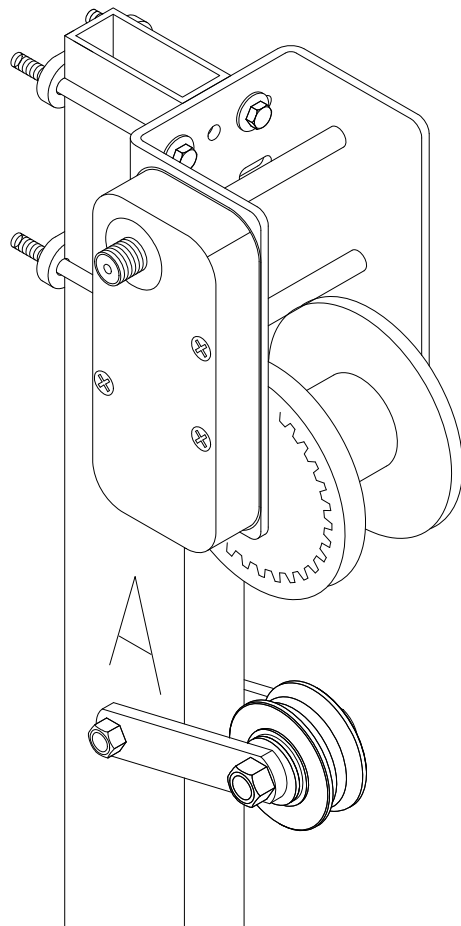

VL 2K LIFT D-L WINCH INSTRUCTIONS



REIMANN & GEORGER CORPORATION
MARINE PRODUCTS
P/N 6112103

BUFFALO, NY
5/15/09

1 SAFETY

1.1 INTRODUCTION

Your Reimann & Georger Corporation Marine Products Aluminum Vertical Lift has been engineered to provide lifting performance, long term economics and safety advantages that no other type can match. However, even a well-designed and well-built lift can malfunction or become hazardous in the hands of an inexperienced and/or untrained user. Therefore, read this manual and related equipment manuals thoroughly before operating your lift to provide maximum safety for all operating personnel, and to get the maximum benefit from your equipment.



WARNING:

DO NOT OPERATE THIS LIFT WITHOUT STUDYING THIS ENTIRE MANUAL. FAILURE TO DO THIS CAN LEAD TO EQUIPMENT MISUSE WITH RESULTING DAMAGE AND/OR SERIOUS PERSONAL INJURY. CONTACT YOUR RGC® MARINE DEALER IF YOU HAVE ANY QUESTIONS.

1.2 SAFETY DEFINITIONS

A safety message alerts you to potential hazards that could hurt you or others or cause property damage. The safety messages or signal words for product safety signs are **DANGER**, **WARNING**, and **CAUTION**. Each safety message is preceded by a safety alert symbol and is defined as follows:

DANGER: Indicates an imminently hazardous situation which, if not avoided, **will** cause death or serious injury. This safety message is limited to the most extreme situations.

WARNING: Indicates a potentially hazardous situation which, if not avoided, **could** result in death or serious injury.

CAUTION: Indicates a potentially hazardous situation which, if not avoided, **may** result in minor or moderate injury. It may also be used to alert against unsafe practices and property-damage-only accidents.

1.3 EQUIPMENT SAFETY LABELS

These labels warn you of potential hazards that could cause injury. Read them carefully. If a label comes off or becomes illegible, contact a Reimann & Georger Corporation dealer for a free replacement.

1.4 EQUIPMENT AND PERSONNEL SAFETY

1. Do not use the lift if it shows any signs of damage.
2. Do not exceed the rated maximum lifting capacity of this equipment.
3. When using a direct drive or motorized friction drive, understand the use of all controls and connections provided with it.



WARNING:

ALL ELECTRIC DRIVES MUST BE INSTALLED AND INSPECTED BY A CERTIFIED ELECTRICIAN IN ACCORDANCE WITH LOCAL ELECTRICAL CODES. THIS INSTALLATION MUST INCLUDE A PROPERLY WORKING GROUND FAULT CIRCUIT INTERRUPTER. (G.F.C.I.)

4. Never try lifting anything other than a boat with this equipment.
5. Never allow people in the boat any time it is suspended above the water on the platform.



WARNING:

DO NOT STAND OR WALK ON THE PLATFORM WHILE IT IS IN ANY RAISED POSITION. THIS CAN CAUSE SERIOUS PERSONAL INJURY.

6. Do not allow anyone to swim or play under, near or on the lift at any time.

1.5 INSTALLATION SAFETY

1. Insure that all bolts and nuts are fastened securely prior to operation.
2. Insure the pulleys spin freely. If any pulley binds, replace it immediately.
3. Do not weld or otherwise modify the lift. Such alterations may weaken the structural integrity of the lift and void the warranty.
4. All lifting accessories such as pontoon brackets, pivoting bunks, and guide-ons, must be commercially manufactured, have a rated load capacity equal to that of the lift, and be properly maintained and installed.
5. Insure that the frame is level and square.
6. The following precautions must be observed when lifting any part of this equipment:
 - a. Be sure of your footing.
 - b. Bend your knees and lift with your legs.
 - c. Hold the equipment section close to your body when lifting.
7. Wear heavy leather gloves when handling wire rope. Insufficient hand protection when handling wire rope can cause personal injury.

1.6 OPERATING SAFETY

1.6.1 General

1. Never use this equipment beyond its rated capacity. This can damage the lift and/or boat with resulting serious personal injury.
2. Before allowing anyone to operate the lift, be certain they fully understand the proper operating procedure.
3. Completely remove any user or dealer installed locking devices before operating the lift.
4. Follow the Pre-Lifting Checklist before operating.
5. Do not try lifting or launching your boat in rough water conditions. This can damage your boat and/or the lift.
6. The boat must be secured on the lift before raising or lowering. Failure to do this can cause equipment damage and/or serious personal injury.
7. Keep people and pets clear during operation of the lift.
8. Keep fingers and clothing clear of all moving parts.
9. Check the lift periodically for frayed cables and/or binding pulleys.
10. Do not attempt to make any adjustments on the lift while it is being operated.
11. Contact your dealer if the winch mechanism fails to perform as described in the Operation chapter of this manual.
12. Never tamper with the winch mechanism. This can cause equipment damage.
13. Do not operate the lift under the influence of drugs, alcohol, or medication.

14. Never use the lift to hang or store any auxiliary equipment such as boating hardware.

1.6.2 Safety When Raising the Boat

1. The handwheel or power drive must turn clockwise when raising the platform. The brake pawl must click, indicating that the brake is operative.
2. Do not try to raise the boat beyond the maximum lifting height of the platform.



WARNING:

IF YOU HAVE TO TURN THE HANDWHEEL COUNTERCLOCKWISE TO RAISE THE PLATFORM, YOU HAVE REEVED THE WINCH INCORRECTLY. YOU WILL IMMEDIATELY ENCOUNTER STRONG RESISTANCE WHICH CAN LEAD TO WINCH DAMAGE AND/OR CABLE BREAKAGE.

1.6.3 Safety When Lowering the Boat

1. The handwheel or power drive must turn counter-clockwise when lowering the platform.



WARNING:

IF YOU HAVE TO LOWER THE PLATFORM BY TURNING THE HANDWHEEL CLOCKWISE, YOU HAVE REEVED THE WINCH INCORRECTLY. THE BRAKE PAWL WILL NOT BE EFFECTIVE WHICH CAN CAUSE AN UNCONTROLLED SPIN-DOWN OR “FREEWHEEL” OF THE HANDWHEEL. IF FREEWHEELING OCCURS, NEVER TRY TO STOP IT.

2. Counter-clockwise rotation of the handwheel allows the self-activating brake mechanism to provide a controlled lowering of the platform.



WARNING:

NEVER RELEASE THE BRAKE PAWL OF THE WINCH. THIS CAN TRIGGER AN UNCONTROLLED SPIN-DOWN OR “FREEWHEEL” OF THE HANDWHEEL.

3. Do not continue lowering the platform after the boat floats freely. Excessive slack in winch cable may cause binding.

1.7 MAINTENANCE AND STORAGE SAFETY

1. At least once a year, the lift must be thoroughly inspected as described in the Maintenance chapter of this manual.
2. Completely lower the platform before performing any type of maintenance or repair.



WARNING:

NEVER ALLOW ANYBODY TO WORK IN OR ON THE BOAT WHEN IT IS SUSPENDED ABOVE THE WATER ON THE LIFT.

3. Immediately replace any components found to be defective as described in Chapter 5—Inspection and Maintenance.

2 INSTALLATION AND SETUP

2.1 PRE-INSTALLATION CHECKS

1. Do not assemble the winch onto the lift if any part shows any sign of damage.
2. Do not weld or otherwise modify the lift. Such alterations may weaken the structural integrity of the lift and void the warranty.
3. This product has been supplied with stainless steel hardware to protect against a harsh marine environment and provide outstanding performance. Due to the chemistry and surface condition of stainless steel, there is a natural tendency for the hardware to “gall, lock up, or seize” during assembly. To prevent this from occurring, it is **highly recommended** that the anti-seize supplied in the hardware bag be applied to the mating surfaces of all stainless steel fasteners before assembly. Lubricants containing molybdenum disulfide, graphite, mica or talc may also be used.



CAUTION:

DO NOT EXCEED THE MAXIMUM TORQUE RATING ON ALL BOLTS OF 20 FT-LBS.



WARNING:

FAILURE TO APPLY A SUITABLE LUBRICANT TO THE MATING SURFACES OF STAINLESS STEEL THREADED FASTENERS MAY CAUSE GALLING AND/OR SEIZING OF ASSEMBLY.

4. All lifting accessories such as pontoon brackets, pivoting bunks, guide-ons, and slings shall be commercially manufactured, have a rated load capacity equal to that of the lift, and be properly maintained and installed. Consult the manufacturer’s separate instructions provided for these accessories.



WARNING:

ALL ELECTRIC DRIVES MUST BE INSTALLED AND INSPECTED BY A CERTIFIED ELECTRICIAN IN ACCORDANCE WITH LOCAL ELECTRICAL CODES. THIS INSTALLATION MUST INCLUDE A PROPERLY WORKING GROUND FAULT CIRCUIT INTERRUPTER. (G.F.C.I.)

2.2 PRIOR TO SETUP

The part reference numbers and letters used in the subassembly drawings of sections 2.3 through 2.9 are the same as those shown in Figure 2-1 and listed in the parts lists of Chapter 4.

2.3 D-L B2502 WINCH MOUNTING

1. Refer to figure 2-1. Install the D-L winch onto the A leg of the lift. Use 3/8-16 x 5-1/2 hhcs (E), flat washer (J), 2-hole plate (A), 3/8” lock washer (C) and 3/8” hex nut to mount the winch. Place the winch so that the top of the winch is flush to the top of the A leg.
2. Attach the cable sheave assembly (2) to the A leg as shown in figure 2-1.

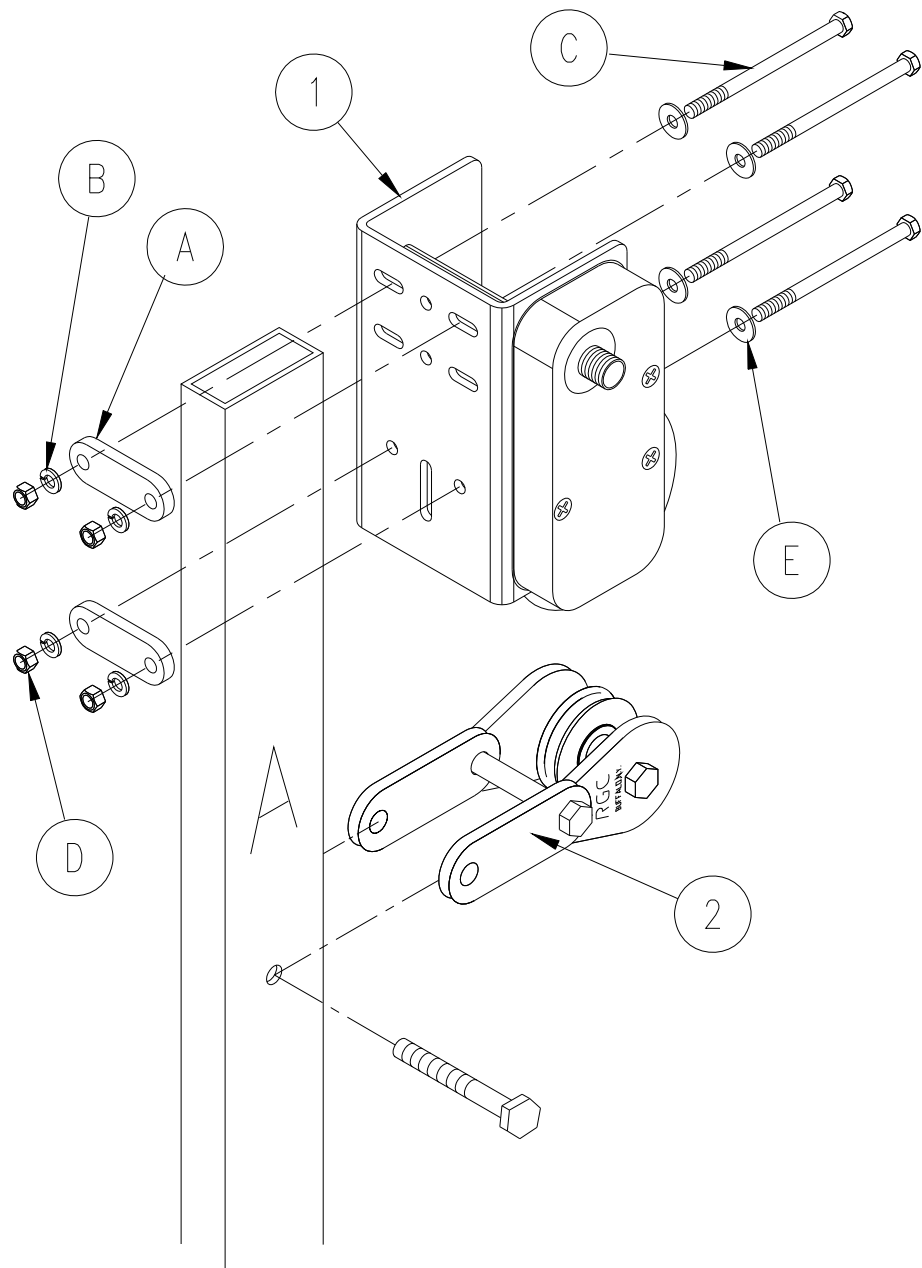

Figure 2-1.
Dutton Lainson Winch Mounted A Leg

2.5 REEVING THE WINCH

1. Refer to Figure 2-2. Reeve the winch cable thru the idler sheave. Next from the front side of winch, reeve the cut end of cable between the winch drum flanges. Insert the cable thru the hole of winch drum flange as shown in Figure 2-6.



CAUTION:

DO NOT ALLOW END OF CABLE TO EXTEND OUT OF THE WINCH DRUM.

2. Insert the cable attaching bolt from the inside of winch drum outward away from the cable. Secure the cable by tightening down the two cable attaching bolt. Make sure the end of the cable does not interfere with the winch frame.



WARNING:

WHEN REEVING THE WINCH, CLOCKWISE ROTATION OF THE SHAFT MUST RAISE, NOT LOWER, THE PLATFORM. IF CLOCKWISE ROTATION OF THE SHAFT LOWERS THE PLATFORM, YOU HAVE REEVED THE WINCH INCORRECTLY.

3. When wrapping the drum, do not allow any horizontal gaps in the cable winding.

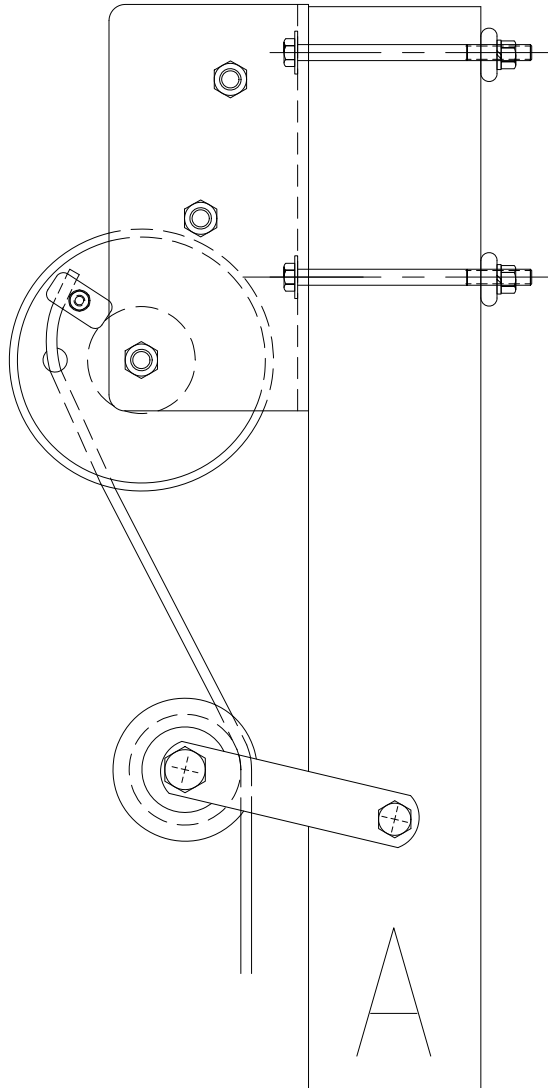

**Figure 2-2.
Winch Cable Reeving**

3 OPERATION

3.1 BEFORE OPERATING THE LIFT

1. Read and know the instructions and insure that everyone understands the proper operating procedure.
2. When using a power drive, understand the use of all controls and connections provided with it.
3. Follow the Pre-Lifting Checklist before operating.
4. Do not use the lift if it shows any signs of damage.
5. Insure that all bolts and nuts are fastened securely prior to operation.
6. Check that the winch is reeved properly. See reeving instructions in Chapter 3 of the lift manual.
7. Never try lifting anything other than a boat with this lift.



WARNING:

NEVER TRY TO USE THIS EQUIPMENT BEYOND ITS RATED CAPACITY. THIS CAN DAMAGE THE LIFT AND/OR BOAT RESULTING IN PERSONAL INJURY.

THE BOAT MUST BE PROPERLY POSITIONED ON THE LIFT BEFORE DOING ANY RAISING OR LOWERING. FAILURE TO DO THIS CAN CAUSE EQUIPMENT DAMAGE AND/OR PERSONAL INJURY.

8. Do not operate the lift under the influence of drugs, alcohol, or medication.
9. Completely remove any user or dealer installed locking devices.
10. Never try to lift or launch your boat in rough water conditions. This can damage your boat and/or the lift.

3.2 TESTING WINCH OPERATION

After the lift installation is complete, it is important that the winch functions properly. Test the winch operation as follows:

1. Raise the empty platform about one-fourth the way up and release the handwheel or stop the power drive. The handwheel or power drive must turn clockwise when raising the platform. The brake pawl must click, indicating that the brake is operative. An empty platform will have a normal tendency to slowly lower itself.



CAUTION:

IF YOU HAVE TO TURN THE HANDWHEEL COUNTERCLOCKWISE TO RAISE THE PLATFORM, YOU HAVE REEVED THE WINCH INCORRECTLY. YOU WILL IMMEDIATELY ENCOUNTER STRONG RESISTANCE WHICH CAN LEAD TO WINCH DAMAGE AND/OR CABLE BREAKAGE.

2. Repeat Step 1 in the half, three-quarters, and full lift positions.
3. Lower the empty platform to repeat steps 1 and 2 with your boat on the lift. The handwheel or power drive must turn counter-clockwise when lowering the platform. When loaded, the self-activating brake mechanism should stop the platform from lowering as soon as the operator stops turning the handwheel. Make sure this brake mechanism is operative.



WARNING:

IF THE HANDWHEEL STARTS TO FREELY SPIN DOWN FROM ANY LOADED TEST POSITION, NEVER TRY TO STOP IT. DO NOT USE A LIFT IN THIS CONDITION.

4. Contact your authorized dealer if the winch mechanism fails to perform as described in this section. Do NOT tamper with the winch mechanism.

3.3 RAISING AND LOWERING THE PLATFORM

1. Raise the platform by turning the handwheel clockwise. The self-activating brake mechanism will hold the platform at any desired height.
2. Platform should be raised a minimum of 1 foot between bottom of boat and highest potential water table height for your geographic area.
3. Lower the platform by turning the handwheel counterclockwise. Do not continue lowering the platform after the boat floats freely from the platform. Excessive winch cable slack may cause cable, lift, and winch damage.
4. Keep fingers and clothing clear of all moving parts. Keep people clear during operation of the lift.
5. Never allow people in the boat any time it is suspended above the water on the lift.



WARNING:

DO NOT STAND OR WALK ON THE LIFT PLATFORM WHILE IT IS IN ANY RAISED POSITION. THIS CAN CAUSE SERIOUS PERSONAL INJURY.

6. Check the lift periodically for frayed cables and/or binding pulleys.
7. When using a power drive, avoid sudden stops.

3.4 SECURING LIFT WHEN NOT IN USE

At the end of operation, secure the lift to prevent unauthorized use. Proceed as follows:

1. Raise the platform to the desired height.
2. Padlock the handwheel to the post or lock out your power drive to prevent unauthorized use when your boat lift is unattended.

4 PARTS LISTS

Each reference number or letter in the following parts lists can be matched with the reference number or letter referred to in both the text and illustrations of Chapter 3, Installation and Setup.



WARNING:

FAILURE TO APPLY A SUITABLE LUBRICANT TO THE MATING SURFACES OF STAINLESS STEEL THREADED FASTENERS MAY CAUSE GALLING AND/OR SEIZING OF ASSEMBLY.

4.1 #3729207 VL2K D-L Carton of Parts

REF #	PART #	QTY	DESCRIPTION
1	3712366	1	WINCH D-L B2502- DRILLED
2	3613407	1	VL1200 WINCH GUIDE SHEAVE ASSY
	3729308	1	VL2K D-L WINCH BAG OF BOLTS consisting of:
A	3603835	2	2-HOLE PLATE 2"
B	5806243	4	3/8" SPLIT LOCK WASHER
C	5896264	4	3/8-16 X 5-1/2 HHCS
D	5896377	4	3/8-16 HEX NUT SS
E	5896406	4	3/8 SAE WASHER SS